

ATLANTIC VERSION TERMINATOR INTERFACE ADAPTER	PART NUMBER	REVISION	DESCRIPTION	FEED TYPE
	2151491-1	M	FINE CRIMP HEIGHT ADJUST	MECHANICAL
	2151491-2	M	FINE CRIMP HEIGHT ADJUST	PNEUMATIC
	2151491-5	M	FINE CRIMP HEIGHT ADJUST	SERVO LATCH PLATE
	2151491-6	M	NON-CRIMP HEIGHT ADJUST	SERVO LATCH PLATE
	2151491-7	M	FINE CRIMP HEIGHT ADJUST	NONE
	7-2151491-7	K	CRIMP TOOLING KIT	-

APPLICATOR DATA		
CRIMP	SIZE	TYPE
WIRE	1.40 mm [.055]	F
INSUL	2.03 mm [.080]	O

APPLICATOR INSTRUCTIONS  
408-10389

TERMINAL DATA: TE TERMINAL	TE CRIMP SPECIFICATION
TERMINAL NAME: MICRO QUADLOK SYSTEM SOCKET CONTACT	
WIRE STRIP LENGTH 3.35-3.65 mm [.132-.144 IN]	INSULATION DIAMETER RANGE Ø1.30-1.90mm [.051-.075 IN]
TERMINAL APPLICATION SPECIFICATION (A) 114-18021 (B) 114-61024	

TERMINALS APPLIED			
GROUP 1		GROUP 2	
TE TERMINAL	TE TERMINAL	TE TERMINAL	TE TERMINAL
(A) 963715-1	(A) 963716-1	(A) 1452013-1	(A) 968221-1
(A) 963715-5	(A) 963716-2	(A) 1-1452013-1	(A) 968221-5
(A) 963715-6	(A) 1-963716-2	(A) 5-1452013-1	(A) 968221-6
(A) 1-963715-5	(A) 5-963716-1	(A) 6-1452013-1	(A) 5-968221-1
(A) 5-963715-1	(A) 5-963716-2		(A) 5-968221-5
(A) 5-963715-5	(A) 5-963716-3		(A) 5-968221-6
(A) 5-963715-6	(A) 6-963716-1		(A) 1241920-1
(A) 6-963715-5	(A) 6-963716-2		(A) 5-1241920-1

WIRE SIZE	CRIMP HEIGHT mm [INCH]	CRIMP HEIGHT REFERENCE SETTING
0.75mm2	1.07+/-0.05 [.042+/-0.002]	6.3
0.50mm2	0.93+/-0.05 [.037+/-0.002]	7.7

- 1. RECOMMENDED SPARE PARTS
- 2. GREASE BEARING SURFACES LIGHTLY
- 3. LUBRICATE DAILY PER THE APPLICATOR INSTRUCTION SHEET SUPPLIED WITH THE APPLICATOR.
- 4. APPLICATOR SPECIFIC DATA TO BE ENTERED INTO BLANK MEMORY CHIP AT ASSEMBLY. SEE BELOW FOR PART NUMBER:  
MECHANICAL FEED WITH "SMART APPLICATOR" CONVERSION: 8-2151491-4  
PNEUMATIC FEED WITH "SMART APPLICATOR" CONVERSION: 8-2151491-4  
SERVO FEED WITH "FINE CRIMP HEIGHT ADJUST": 8-2151491-5  
SERVO FEED WITH "NON-CRIMP HEIGHT ADJUST": 8-2151491-6
- 5. ADJUSTMENT OF THE STRIPPER MAY BE REQUIRED WHEN MOVING THE APPLICATOR BETWEEN BENCH AND LEADMAKER APPLICATIONS.
- 6. APPLY PART NUMBER 1-23419-5 LOCTITE TO THREADS OF ITEM 62. APPLY PART NUMBER 2-23419-6 LOCTITE TO THREADS OF ITEM 242. FOR -6 ONLY APPLY PART NUMBER 1-23419-5 LOCTITE TO THREADS OF ITEM 37.
- 7. GREASE THREADS, GROOVE AND O-RING ON ITEMS 35 & 252.
- 8. MAGNET, ITEM 166 MUST BE ORIENTED CORRECTLY IN ORDER TO PROPERLY ACTUATE THE COUNTER.
- 9. CRIMP HEIGHT REFERENCE SETTING WAS THE SETTING USED WHEN THE APPLICATOR WAS QUALIFIED AT THE FACTORY. ADJUSTMENT MAY BE NECESSARY WHEN RUNNING APPLICATOR IN THE FIELD.
- 10. SPARE FEED CAM STORAGE LOCATION REFER TO INSTRUCTION SHEET FOR ADDITIONAL INFORMATION.
- 11. TO CONVERT THE APPLICATOR TO A NON-CARRIER CUTTING STYLE, REMOVE ITEM 13 AND ATTACH TO THE LOCATION ON THE BACK SIDE OF THE HOUSING. REFER TO INSTRUCTION SHEET FOR ADDITIONAL INFORMATION.
- 12. WHEN ASSEMBLING -6 NON-CRIMP HEIGHT ADJUST APPLICATOR USE SHIM PACK 2119957-2 TO ALIGN APPLICATOR'S MAXIMUM WIRE CRIMP HEIGHT AT NORMAL TERMINATOR SHUT HEIGHT
- 13. CUT TO LENGTH AT ASSEMBLY.

TERMINAL DATA: TE TERMINAL	TE CRIMP SPECIFICATION
TERMINAL NAME: MICRO QUADLOK SYSTEM SOCKET CONTACT	
WIRE STRIP LENGTH 3.35-3.65 mm [.132-.144 IN]	INSULATION DIAMETER RANGE Ø1.40-1.90 mm [.055-.075 IN]
TERMINAL APPLICATION SPECIFICATION (A) 114-18021 (B) 114-61024	

TERMINALS APPLIED			
GROUP 1		GROUP 2	
TE TERMINAL	TE TERMINAL	TE TERMINAL	TE TERMINAL
(A) 1801529-1	(A) 1801529-2	(A) 1703282-1	(A) 5-1703282-1
		(A) 1703282-2	(A) 5-1703282-2

- 1. POSITION THE HOLD DOWN, ITEM 18, IN ORIENTATION 1 FOR GROUP 1 TERMINALS. REFER TO SHEET 2.
- 2. POSITION THE HOLD DOWN, ITEM 18, IN ORIENTATION 2 FOR GROUP 2 TERMINALS. REFER TO SHEET 2.
- 3. TERMINAL LUBRICANT IS RECOMMENDED.

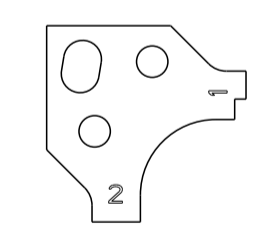
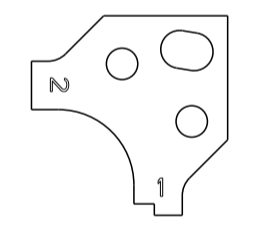

**\*WARNING**  
ON INSTALLATION, SET WIRE DISC, ITEM 40 TO LARGEST WIRE SIZE SETTING. USE OF SETTINGS BELOW MINIMUM REQUIRED CRIMP HEIGHT SETTING WILL CAUSE DAMAGE TO CRIMP TOOLING.

ATLANTIC VERSION  
Shown on sheets 1 of 4 & 2 of 4  
(Pacific version shown on sheets 3 of 4 & 4 of 4)

SET UP GAUGE	LOC	DIST	REVISIONS					
2119599-1	A	66	P	LTN	DESCRIPTION	DATE	OWN	APVD
			L		ECR-16-004202	21MAR2016	YY	JT
			M		ECR-17-005005	06APR2017	TB	GB

-	-	1	-	-	-	2119957-2	APPLICATOR SHIM PACK	260
-	1	-	1	1	1	8-21084-0	O-RING, .676 ID, .070 DIA. MAT.	252
-	-	-	-	1	-	2119640-1	PUSH ROD, AIR FEED	250
-	-	-	-	1	-	2079988-1	BUSHING, LCH5-12, MISUMI	249
-	-	-	-	1	-	2119641-1	FEED CAM, AIR FEED	248
-	1	-	1	1	1	2119798-1	DETENT PIN	247
-	1	-	1	1	1	1-22279-3	SPRING, COMPRESSION	246
-	-	1	-	-	-	2119758-1	RAM, AMP STYLE, SIDE FEED, NON-ADJ.	245
-	1	1	1	1	1	2119082-5	CAM, SNAIL, INSULATION ADJUSTMENT	244
-	1	1	1	1	1	2079764-1	WASHER, WAVE SPRING, CREST-TO-CREST	243
-	1	1	1	1	1	2119083-1	RETAINER, INSULATION DIAL	242
-	1	1	1	1	1	7-18023-7	SCR, SKT HD CAP M3 X 4.0	241
-	-	2	2	-	-	2168400-6	SHCS, LOW HEAD, RoHS, M5 X 16	240
-	-	-	-	-	1	2119580-1	MECHANICAL FEED ASSEMBLY	239
-	-	-	-	1	-	2063440-1	AIR FEED MODULE	238
-	-	1	1	-	-	2119740-2	TAG IDENTIFICATION	213
-	-	1	1	-	-	1901094-3	SPACER, FEEDER	198
-	-	-	-	2	-	21045-3	RING, RETAIN, EXTERN, 3/16 CRESCENT	172
-	1	1	1	1	1	994969-1	MAGNET, RARE EARTH HIGH ENERGY	166
-	REF	REF	REF	REF	REF	994970-2	COUNTER, MAGNETIC	164
-	-	-	-	1	-	240638-1	SPRING, FEED FINGER	163
-	-	-	-	1	-	3-23627-7	PIN, RETAIN, GRVD, 3/16 X .854	137
-	-	-	-	1	-	2119799-1	HOLDER, FEED FINGER, AF	136
-	-	REF	REF	-	-	SEE NOTE 4	MEMORY CHIP, PROGRAMMED	135
-	-	1	1	-	-	1633743-1	SERVO FEED LATCH ASM	133
-	1	1	1	1	1	1-18028-2	WASHER, FLAT, REG M4	119
-	-	REF	REF	-	-	2119944-1	FEED FINGER ASSEMBLY, SF	117
-	1	1	1	1	1	2119955-1	ASSY, LUBRICATOR, SIDE FEED	113
-	1	1	1	1	1	455888-6	SPACER, CRIMPER	82
-	1	1	1	1	1	240641-9	SPACER	81
-	1	1	1	1	1	2119956-1	DOCUMENTATION PACKAGE	71
-	1	1	1	1	1	2119791-9	DEPRESSOR, WIRE	70
-	1	-	-	1	1	2119740-1	TAG IDENTIFICATION	67
-	2	2	2	2	2	2168078-1	SCREW, DRIVE, RH, RoHS, 2 x .188	66
-	1	-	1	1	1	2119793-1	LIMITER, ADJUSTMENT BOLT	63
-	3	-	3	3	3	992763-5	SCR, SET, SOC, CONE POINT, M3 X 4.0	62
-	1	1	1	1	1	2079383-4	SCR, BHSC, RoHS (M4 X 8)	60
-	-	-	-	1	1	5-18022-5	SCR, HEX HD CAP, M4 X 6.0	59
-	-	-	-	1	1	1338685-1	PAWL, FEED	56
-	4	4	4	4	4	2168400-1	SHCS, LOW HEAD, RoHS, M4 X 12	54
-	2	2	2	2	2	1-2168083-0	SCR, SKT HD CAP, RoHS, M4 X 10	53
-	-	-	-	1	2	18023-9	SCR, SKT HD CAP M4 X 6.0	49
-	-	-	-	1	1	2119652-1	FEED CAM, PRE FEED	48
-	-	-	-	1	1	2119653-1	FEED CAM, POST FEED	47
-	1	1	1	1	1	2119656-9	APPLICATOR BASIC ASSEMBLY, SF	46
-	1	-	1	1	1	2119370-1	RAM, AMP STYLE, SIDE FEED	44
-	1	1	1	1	1	2079383-7	SCR, BHSC, RoHS (M8 X 25)	41
-	1	-	1	1	1	2119645-1	DISC, NUMBERED FA WIRE ADJUSTMENT	40
-	1	-	1	1	1	2119957-1	APPLICATOR SHIM PACK	39
-	1	1	1	1	1	2119644-1	RAM WASHER, PRECISION	38
-	1	1	1	1	1	2119085-1	FA HEAD, ATLANTIC STYLE	37
-	1	-	1	1	1	2119092-1	BOLT, ADJUSTMENT	35
-	1	1	1	1	1	1752356-3	SUPPORT, TERMINAL	34
-	2	2	2	2	2	2079383-5	SCR, BHSC, RoHS (M4 X 20)	33
-	1	1	1	1	1	2161328-1	HEX HEAD, FLANGED, M5 X 8mm LONG	32
-	1	1	1	1	1	1320908-6	SPACER, STRIP GUIDE	30
-	1	1	1	1	1	2119959-1	ASSEMBLY, STRIP GUIDE	29
-	1	1	1	1	1	1320928-2	STRIP GUIDE	24
-	1	1	1	1	1	2168083-2	SCR, SKT HD CAP, RoHS, M4 X 8.0	21
-	1	1	1	1	1	1-18028-2	WASHER, FLAT, REG M4	20
-	1	1	1	1	1	2119533-1	STRIPPER, SIDE FEED	19
-	1	1	1	1	1	2217529-1	TERMINAL HOLD DOWN	18
-	1	1	1	1	1	2119806-1	INSERT, SHEAR	13
-	1	1	1	1	1	3-22280-3	SPRING, COMPRESSION	12
-	1	1	1	1	1	1-356885-4	STOP, SHEAR	11
-	1	1	1	1	1	2119805-1	SHEAR HOLDER, FRONT	10
-	1	1	1	1	1	1803095-3	FLOATING SHEAR, FRONT	9
-	1	1	1	1	1	1-1338690-1	ANVIL, COMBINATION .055	8
-	1	1	1	1	1	1-240641-1	SPACER	7
-	1	1	1	1	1	2119757-4	DEPRESSOR, SHEAR	5
-	1	1	1	1	1	238011-9	BLOCK, CRIMPER SPACER	4
-	1	1	1	1	1	2-1633966-9	CRIMPER, INSULATION O	3
-	1	1	1	1	1	3-1633860-8	CRIMPER, WIRE	1

ITEM NO	PART NO	DESCRIPTION	ITEM NO
-77	-7	-6	-5
-2	-1		

THIS DRAWING IS UNPUBLISHED. RELEASED FOR PUBLICATION 2011	BY TYCO ELECTRONICS CORPORATION. ALL RIGHTS RESERVED.	OWN: D. WEAVER 31AUG2011	CHK: G. HOFFNER 31AUG2011	APVD: T. ELBIN 31AUG2011	NAME: Ocean Side Feed Applicator
DIMENSIONS: mm	TOLERANCES UNLESS OTHERWISE SPECIFIED:	0 PLC ±	1 PLC ±	2 PLC ±	3 PLC ±
MATERIAL:	FINISH:	WEIGHT:	SCALE: 1:2	SHEET 1 OF 4	REV M

LOC	DIST	REV	DESCRIPTION	DATE	OWN	APVD
A	66		SEE SHEET 1			

### FEED TYPE MECHANICAL

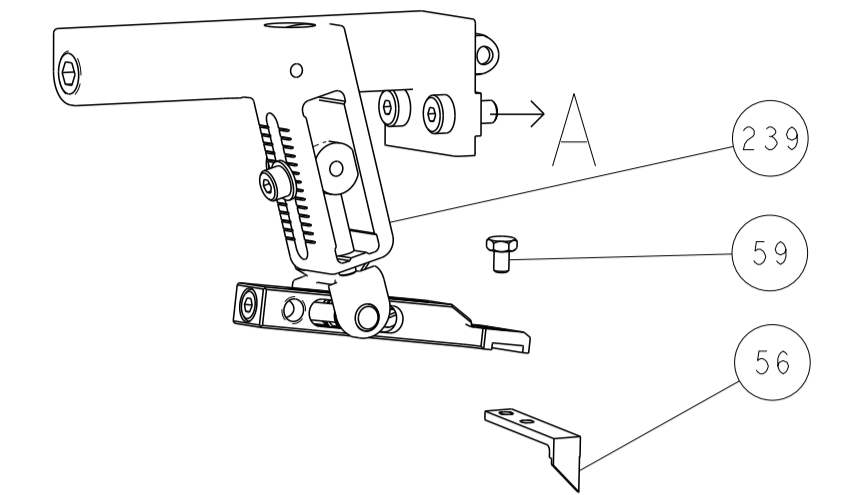

### PNEUMATIC

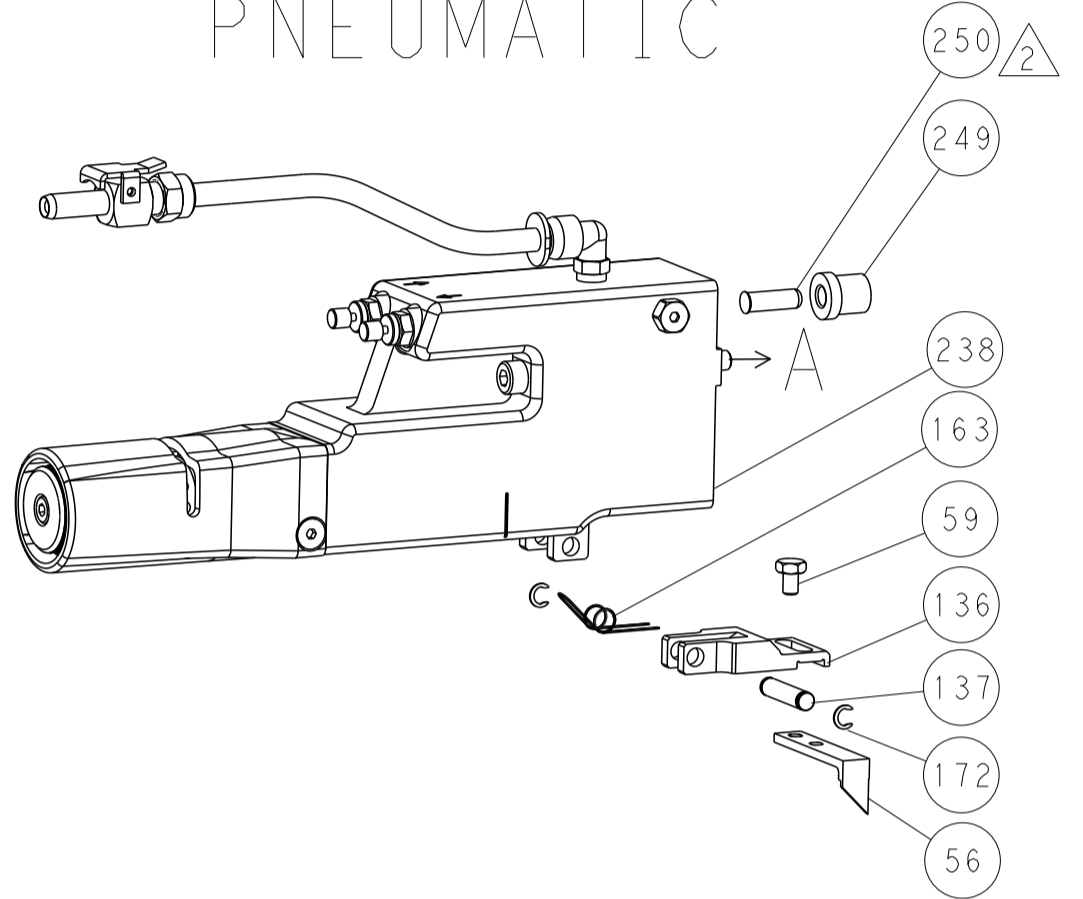

### SERVO LATCH PLATE

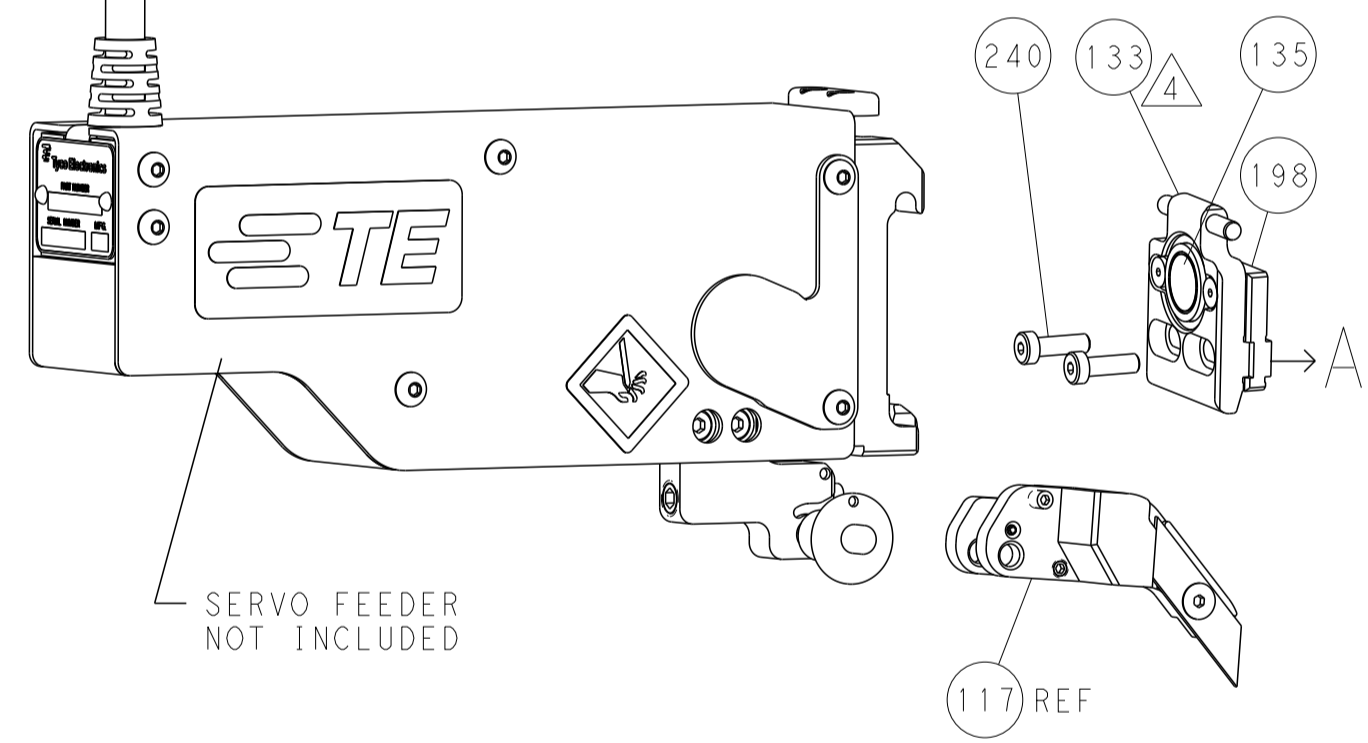

### CAM POSITIONS

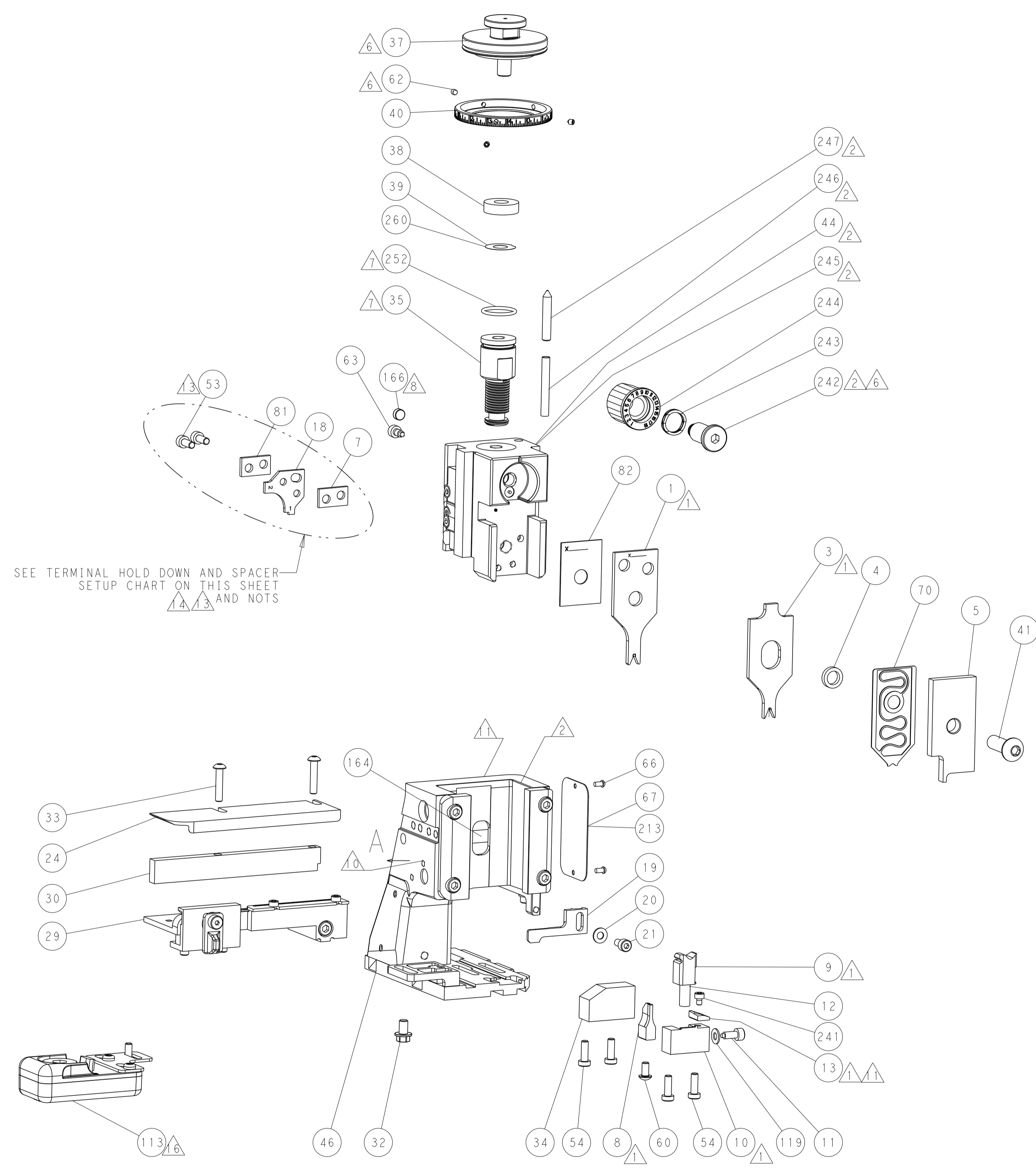
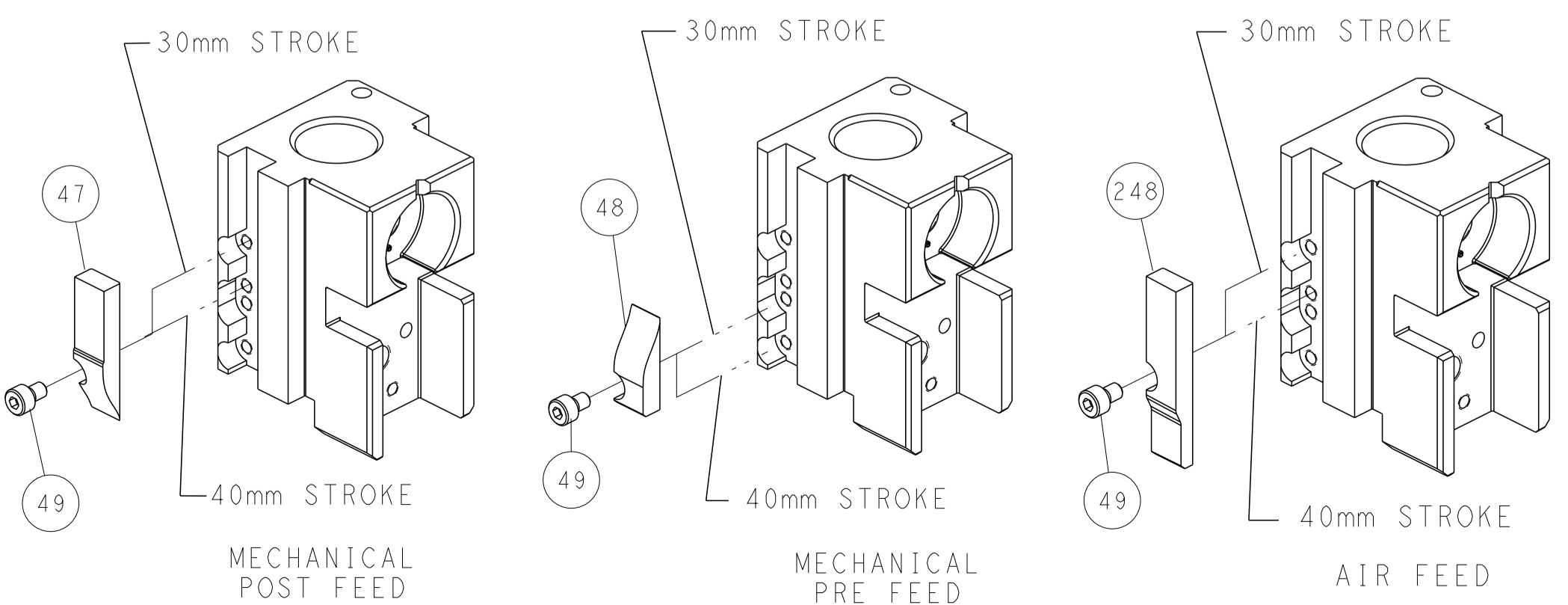

SEE TERMINAL HOLD DOWN AND SPACER SETUP CHART ON THIS SHEET AND NOTS

HOLD DOWN & SPACER TOOLING SETUP FOR TERMINALS:		POSITION 1
963715-1	963716-1	
963715-5	963716-2	
963715-6	1-963716-2	
1-963715-5	5-963716-1	
5-963715-1	5-963716-2	
5-963715-5	5-963716-3	
5-963715-6	6-963716-1	POSITION 1
6-963715-5	6-963716-2	
1801529-1	1703298-1	
1801529-2	1703298-5	
2141399-6	2005120-1	
HOLD DOWN & SPACER TOOLING SETUP FOR TERMINALS:		POSITION 1
1452013-1		
1-1452013-1		
5-1452013-1		
6-1452013-1		
HOLD DOWN & SPACER TOOLING SETUP FOR TERMINALS:		POSITION 2
968221-1	1703282-1	
968221-5	1703282-2	
968221-6	5-1703282-1	
5-968221-1	5-1703282-2	
5-968221-5	1379418-1	
5-968221-6	1379418-2	
HOLD DOWN & SPACER TOOLING SETUP FOR TERMINALS:		POSITION 2
1241920-1		
5-1241920-1		

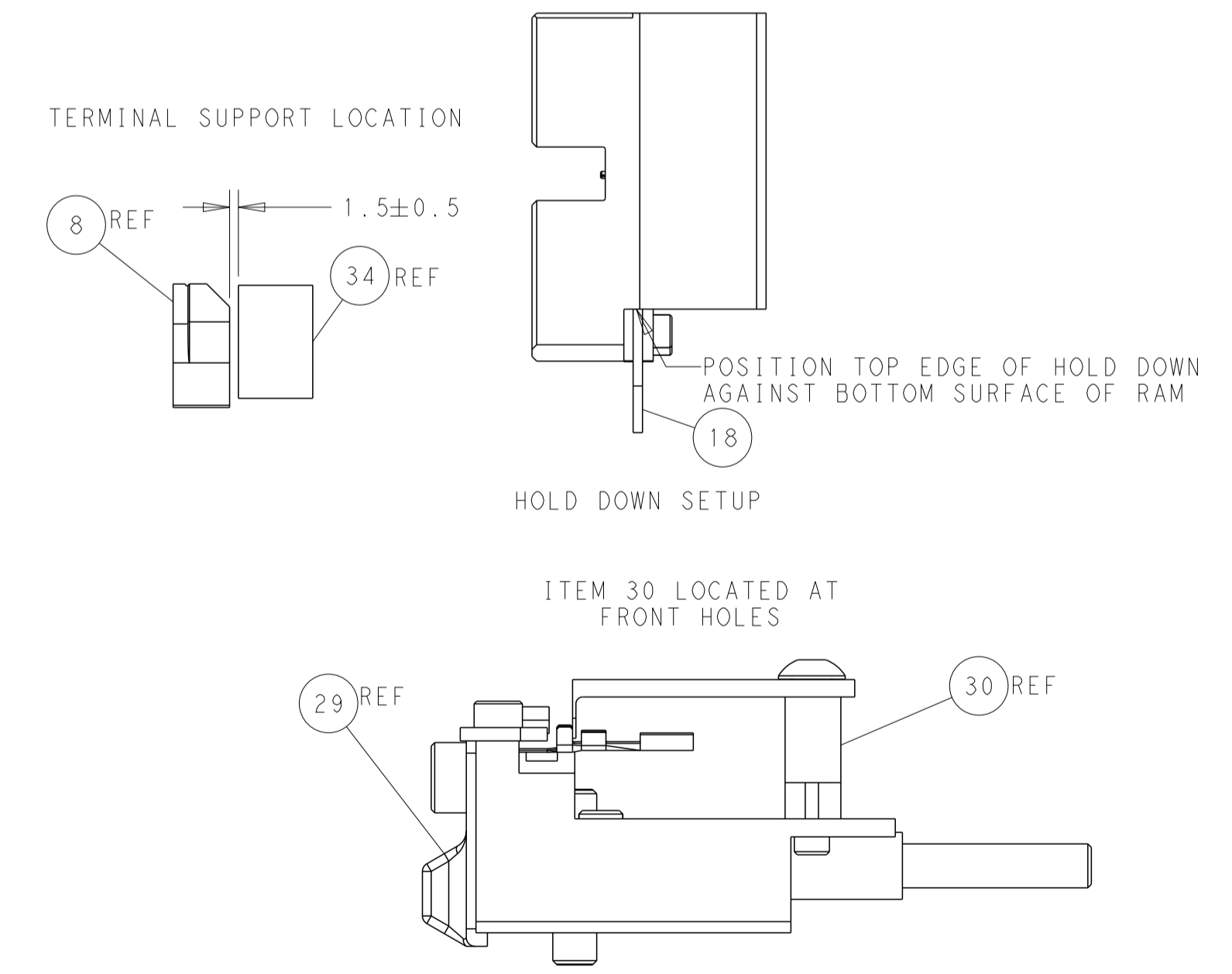

**ATLANTIC VERSION**  
 Shown on sheets 1 of 4 & 2 of 4  
 (Pacific version shown on sheets 3 of 4 & 4 of 4)

DIMENSIONS:		TOLERANCES UNLESS OTHERWISE SPECIFIED:		OWN: B. WEAVER 31AUG2011	TE Connectivity
mm	0 PLC ±	1 PLC ±	2 PLC ±	CHK: G. HOFFNER 31AUG2011	Harrisburg, PA 17105-3608
	3 PLC ±	4 PLC ±	ANGLES ±	APVD: J. ELBIN 31AUG2011	NAME: Ocean Side Feed Applicator
MATERIAL:	FINISH:	WEIGHT:	SCALE: 1:2	SIZE: A1	CAGE CODE: 00779
Customer Accessible Production Drawing				SHEET: 2 of 4	REV: M

PACIFIC VERSION TERMINATOR INTERFACE ADAPTER	PART NUMBER	REVISION	DESCRIPTION	FEED TYPE	APPLICATOR STYLE CONVERSION CHART						
					CONVERT TO	PART NUMBERS REQUIRED					
	2-2151491-1	M	FINE CRIMP HEIGHT ADJUST	MECHANICAL	PNEUMATIC FEED	2119950-1	1338685-1	5-18022-5	2119641-2	2119799-1	2063440-1
					SERVO LATCH PLATE	2119951-1	-	8-2151491-5	1901094-3	-	2168400-6 (QUANTITY 2)
					SMART APPLICATOR	2161326-1	-	8-2151491-4	-	-	-
	2-2151491-2	M	FINE CRIMP HEIGHT ADJUST	PNEUMATIC	MECHANICAL FEED	2119949-1	1338685-1	5-18022-5	2119653-2	-	-
					SERVO LATCH PLATE	2119951-1	-	8-2151491-5	1901094-3	-	2168400-6 (QUANTITY 2)
					SMART APPLICATOR	2161326-1	-	8-2151491-4	-	-	-
	2-2151491-5	M	FINE CRIMP HEIGHT ADJUST	SERVO LATCH PLATE	MECHANICAL FEED	2119949-1	1338685-1	5-18022-5	2119653-2	-	-
					PNEUMATIC FEED	2119950-1	1338685-1	5-18022-5	2119641-2	2119799-1	2063440-1
	2-2151491-7	M	FINE CRIMP HEIGHT ADJUST	NONE	-	-	-	-	-	-	-
	7-2151491-7	K	CRIMP TOOLING KIT	-	-	-	-	-	-	-	-

APPLICATOR DATA		
CRIMP	SIZE	TYPE
WIRE	1.40 mm [.055]	F
INSUL	2.03 mm [.080]	O
APPLICATOR INSTRUCTIONS 408-10389		

TERMINAL DATA: TE TERMINAL		TE CRIMP SPECIFICATION	
TERMINAL NAME: MICRO QUADLOK SYSTEM SOCKET CONTACT			
WIRE STRIP LENGTH		INSULATION DIAMETER RANGE	
3.35-3.65 mm [.132-.144 IN]		Ø1.30-1.90mm [.051-.075 IN]	
TERMINAL APPLICATION SPECIFICATION	(A) 114-18021 (B) 114-61024		
TERMINALS APPLIED			
GROUP 1		GROUP 2	
TE TERMINAL	TE TERMINAL	TE TERMINAL	TE TERMINAL
(A) 963715-1	(A) 963716-1	(A) 1452013-1	(A) 968221-1
(A) 963715-5	(A) 963716-2	(A) 1-1452013-1	(A) 968221-5
(A) 963715-6	(A) 1-963716-2	(A) 5-1452013-1	(A) 968221-6
(A) 1-963715-5	(A) 5-963716-1	(A) 6-1452013-1	(A) 5-968221-1
(A) 5-963715-1	(A) 5-963716-2		(A) 5-968221-5
(A) 5-963715-5	(A) 5-963716-3		(A) 5-968221-6
(A) 5-963715-6	(A) 6-963716-1		(A) 1241920-1
(A) 6-963715-5	(A) 6-963716-2		(A) 5-1241920-1

TERMINAL DATA: TE TERMINAL		TE CRIMP SPECIFICATION	
TERMINAL NAME: MICRO QUADLOK SYSTEM SOCKET CONTACT			
WIRE STRIP LENGTH		INSULATION DIAMETER RANGE	
3.35-3.65 mm [.132-.144 IN]		Ø1.40-1.90 mm [.055-.075 IN]	
TERMINAL APPLICATION SPECIFICATION	(A) 114-18021 (B) 114-61024		
TERMINALS APPLIED			
GROUP 1		GROUP 2	
TE TERMINAL	TE TERMINAL	TE TERMINAL	TE TERMINAL
(A) 1801529-1	(A) 1801529-2	(A) 1703282-1	(A) 5-1703282-1
		(A) 1703282-2	(A) 5-1703282-2

TERMINAL DATA: TE TERMINAL		TE CRIMP SPECIFICATION	
TERMINAL NAME: MICRO QUADLOK SYSTEM SOCKET CONTACT			
WIRE STRIP LENGTH		INSULATION DIAMETER RANGE	
3.35-3.65 mm [.132-.144 IN]		Ø1.70-1.90mm [.067-.075 IN]	
TERMINAL APPLICATION SPECIFICATION	(A) 114-18021 (B) 114-61024		
TERMINALS APPLIED			
GROUP 1		GROUP 2	
TE TERMINAL	TE TERMINAL	TE TERMINAL	TE TERMINAL
(A) 1379418-1		(A) 1703298-1	(B) 2005120-1
(A) 1379418-2		(A) 1703298-5	(A) 2141399-6

WIRE SIZE	CRIMP HEIGHT mm [INCH]	CRIMP HEIGHT REFERENCE SETTING
0.75mm2	1.07+/-0.05 [.042+/-0.002]	6.3
0.50mm2	0.93+/-0.05 [.037+/-0.002]	7.7

- RECOMMENDED SPARE PARTS
- GREASE BEARING SURFACES LIGHTLY
- 3. LUBRICATE DAILY PER THE APPLICATOR INSTRUCTION SHEET SUPPLIED WITH THE APPLICATOR.
- APPLICATOR SPECIFIC DATA TO BE ENTERED INTO BLANK MEMORY CHIP AT ASSEMBLY. SEE BELOW FOR PART NUMBER:  
MECHANICAL FEED WITH "SMART APPLICATOR" CONVERSION: 8-2151491-4  
PNEUMATIC FEED WITH "SMART APPLICATOR" CONVERSION: 8-2151491-4  
SERVO FEED WITH "FINE CRIMP HEIGHT ADJUST": 8-2151491-5
- 5. ADJUSTMENT OF THE STRIPPER MAY BE REQUIRED WHEN MOVING THE APPLICATOR BETWEEN BENCH AND LEADMAKER APPLICATIONS.
- APPLY PART NUMBER 1-23419-5 LOCTITE TO THREADS OF ITEM 62.  
APPLY PART NUMBER 2-23419-6 LOCTITE TO THREADS OF ITEM 242.
- GREASE THREADS, GROOVE AND O-RING ON ITEMS 139 & 152.
- MAGNET MUST BE ORIENTED CORRECTLY IN ORDER TO PROPERLY ACTUATE THE COUNTER.
- CRIMP HEIGHT REFERENCE SETTING WAS THE SETTING USED WHEN THE APPLICATOR WAS QUALIFIED AT THE FACTORY. ADJUSTMENT MAY BE NECESSARY WHEN RUNNING APPLICATOR IN THE FIELD.
- SPARE FEED CAM STORAGE LOCATION REFER TO INSTRUCTION SHEET FOR ADDITIONAL INFORMATION.
- TO CONVERT THE APPLICATOR TO A NON-CARRIER CUTTING STYLE, REMOVE ITEM 13 AND ATTACH TO THE LOCATION ON BACK SIDE OF THE HOUSING. REFER TO INSTRUCTION SHEET FOR ADDITIONAL INFORMATION.
- CUT TO LENGTH AT ASSEMBLY.

POSITION THE HOLD DOWN, ITEM 18, IN ORIENTATION 1 FOR GROUP 1 TERMINALS. REFER TO SHEET 2.

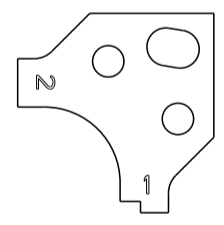

POSITION THE HOLD DOWN, ITEM 18, IN ORIENTATION 2 FOR GROUP 2 TERMINALS. REFER TO SHEET 2.

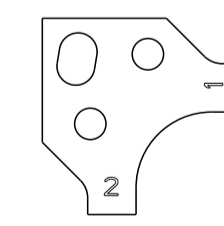

TERMINAL LUBRICANT IS RECOMMENDED.

**\*WARNING**  
 ON INSTALLATION, SET WIRE DISC, ITEM 40 TO LARGEST WIRE SIZE SETTING. USE OF SETTINGS BELOW MINIMUM REQUIRED CRIMP HEIGHT SETTING WILL CAUSE DAMAGE TO CRIMP TOOLING.

**PACIFIC VERSION**  
 Shown on sheets 3 of 4 & 4 of 4  
 (Atlantic version shown on sheets 1 of 4 & 2 of 4)

SET UP GAUGE	LOC	DIST	REVISIONS					
2119599-1	A	66	P	LTN	DESCRIPTION	DATE	OWN	APVD
			-	-	SEE SHEET 1	-	-	-

-	1	1	1	1	2119782-1	FINE ADJUST HEAD ASM, PACIFIC STYLE	251
-	-	-	1	-	2119640-1	PUSH ROD, AIR FEED	250
-	-	-	-	1	2079988-1	BUSHING, LCH5-12, MISUMI	249
-	1	1	1	1	1-22279-3	SPRING, COMPRESSION	246
-	1	1	1	1	2119082-5	CAM, SNAIL, INSULATION ADJUSTMENT	244
-	1	1	1	1	2079764-1	WASHER, WAVE SPRING, CREST-TO-CREST	243
	1	1	1	1	2119083-1	RETAINER, INSULATION DIAL	242
-	1	1	1	1	7-18023-7	SCR, SKT HD CAP M3 X 4.0	241
-	-	2	-	-	2168400-6	SHCS, LOW HEAD, RoHS, M5 X 16	240
-	-	-	-	1	2119580-1	MECHANICAL FEED ASSEMBLY	239
-	-	-	-	1	2063440-1	AIR FEED MODULE	238
-	-	-	1	-	2119740-2	TAG, IDENTIFICATION	213
-	-	-	1	-	1901094-3	SPACER, FEEDER	198
-	-	-	2	-	21045-3	RING, RETAIN, EXTERN, 3/16 CRESCENT	172
-	1	1	1	1	994969-1	MAGNET, RARE EARTH HIGH ENERGY	166
-	REF	REF	REF	REF	994970-2	COUNTER, MAGNETIC	164
-	-	-	1	-	240638-1	SPRING, FEED FINGER	163
	1	1	1	1	8-21084-1	O-RING, .801 ID, .070 DIA. MAT.	152
-	-	-	-	1	2119641-2	FEED CAM, AIR FEED	151
-	1	1	1	1	2119798-2	DETENT PIN	145
-	1	1	1	1	2079383-8	SCR, BHSC, RoHS (M4 X 16)	144
-	4	4	4	4	2168400-5	SHCS, LOW HEAD, RoHS, M4 X 20	143
-	-	-	-	1	2119653-2	FEED CAM, POST FEED	142
-	1	1	1	1	1-2119656-0	APPLICATOR BASIC ASSEMBLY, SF	141
-	1	1	1	1	2119650-1	RAM, ASIAN STYLE, SIDE FEED	140
	1	1	1	1	2119092-2	BOLT, ADJUSTMENT	139
-	-	-	1	-	3-23627-7	PIN, RETAIN, GRVD, 3/16 X .854	137
-	-	-	-	1	2119799-1	HOLDER, FEED FINGER, AF	136
	-	-	REF	-	SEE NOTE 4	MEMORY CHIP, PROGRAMMED	135
-	-	-	1	-	1633743-1	SERVO FEED LATCH ASM	133
-	1	1	1	1	1-18028-2	WASHER, FLAT, REG M4	119
-	-	REF	-	-	2119944-1	FEED FINGER ASSEMBLY, SF	117
	1	1	1	1	2119955-1	ASSY, LUBRICATOR, SIDE FEED	113
-	1	1	1	1	455888-6	SPACER, CRIMPER	82
-	1	1	1	1	240641-9	SPACER	81
-	1	1	1	1	2119956-1	DOCUMENTATION PACKAGE	71
-	1	1	1	1	2119791-9	DEPRESSOR, WIRE	70
-	1	-	1	1	2119740-1	TAG, IDENTIFICATION	67
-	2	2	2	2	2168078-1	SCREW, DRIVE, RH, RoHS, 2 x .188	66
-	1	1	1	1	2119793-1	LIMITER, ADJUSTMENT BOLT	63
	3	3	3	3	992763-5	SCR, SET, SOC, CONE POINT, M3 x 4.0	62
-	-	-	-	1	5-18022-5	SCR, HEX HD CAP, M4 X 6.0	59
-	-	-	-	1	1338685-1	PAWL, FEED	56
	2	2	2	2	1-2168083-0	SCR, SKT HD CAP, RoHS, M4 X 10	53
-	-	-	-	1	18023-9	SCR, SKT HD CAP M4 X 6.0	49
-	-	-	-	1	2119652-1	FEED CAM, PRE FEED	48
-	1	1	1	1	2079383-7	SCR, BHSC, RoHS (M8 X 25)	41
-	1	1	1	1	2119645-1	DISC, NUMBERED FA WIRE ADJUSTMENT	40
-	1	1	1	1	2119957-1	APPLICATOR SHIM PACK	39
-	1	1	1	1	2119644-1	RAM WASHER, PRECISION	38
-	1	1	1	1	1752356-3	SUPPORT, TERMINAL	34
-	2	2	2	2	2079383-5	SCR, BHSC, RoHS (M4 X 20)	33
-	1	1	1	1	2161328-1	HEX HEAD, FLANGED, M5 x 8mm LONG	32
-	1	1	1	1	1320908-6	SPACER, STRIP GUIDE	30
-	1	1	1	1	2119959-1	ASSEMBLY, STRIP GUIDE	29
-	1	1	1	1	1320928-2	STRIP GUIDE	24
-	1	1	1	1	2168083-2	SCR, SKT HD CAP, RoHS, M4 X 8.0	21
-	1	1	1	1	1-18028-2	WASHER, FLAT, REG M4	20
-	1	1	1	1	2119533-1	STRIPPER, SIDE FEED	19
-	1	1	1	1	2217529-1	TERMINAL HOLD DOWN	18
	1	1	1	1	2119806-1	INSERT, SHEAR	13
-	1	1	1	1	3-22280-3	SPRING, COMPRESSION	12
-	1	1	1	1	1-356885-4	STOP, SHEAR	11
	1	1	1	1	2119805-1	SHEAR HOLDER, FRONT	10
	1	1	1	1	1803095-3	FLOATING SHEAR, FRONT	9
	1	1	1	1	1-1338690-1	ANVIL, COMBINATION .055	8
-	1	1	1	1	1-240641-1	SPACER	7
-	1	1	1	1	2119757-4	DEPRESSOR, SHEAR	5
-	1	1	1	1	238011-9	BLOCK, CRIMPER SPACER	4
	1	1	1	1	2-1633966-9	CRIMPER, INSULATION O	3
	1	1	1	1	3-1633860-8	CRIMPER, WIRE	1

DIMENSIONS:		TOLERANCES UNLESS OTHERWISE SPECIFIED:		DRAWING NO		DESCRIPTION		ITEM NO	
mm	0 PLC ±	1 PLC ±	2 PLC ±	3 PLC ±	4 PLC ±	5 PLC ±	6 PLC ±	7 PLC ±	8 PLC ±
	ANGLES	FINISH							
MATERIAL									
Customer Accessible Production Drawing				SCALE	1:2	SHEET	3	OF	4

LOC	DIST	REV	DATE	BY	APPV
A	66				

# FEED TYPE MECHANICAL

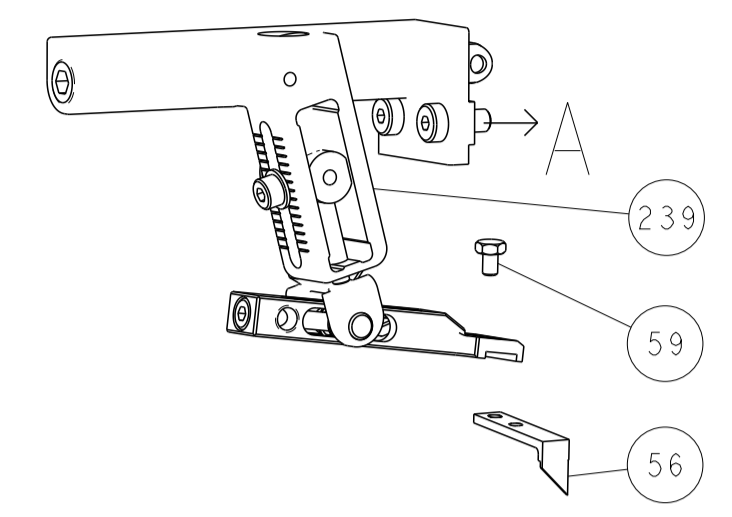

# PNEUMATIC

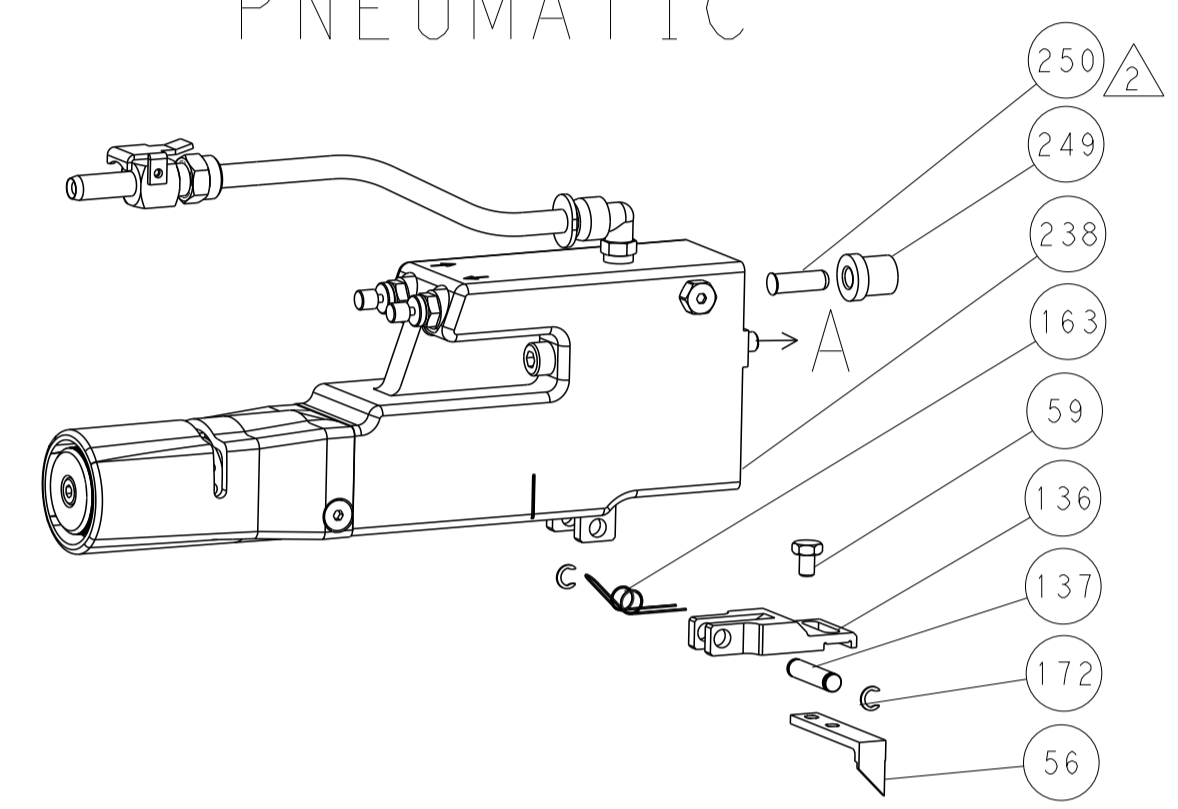

# SERVO LATCH PLATE

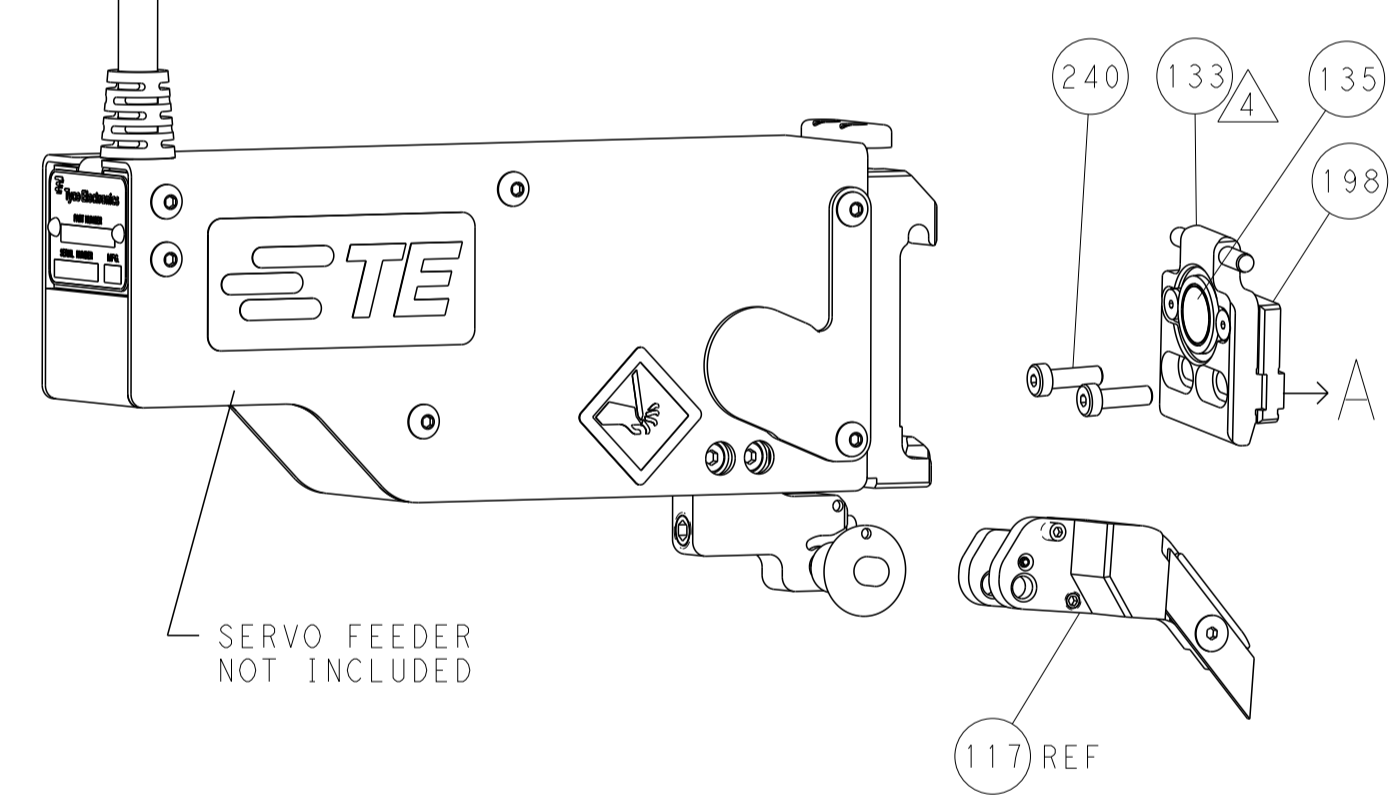

# CAM POSITIONS

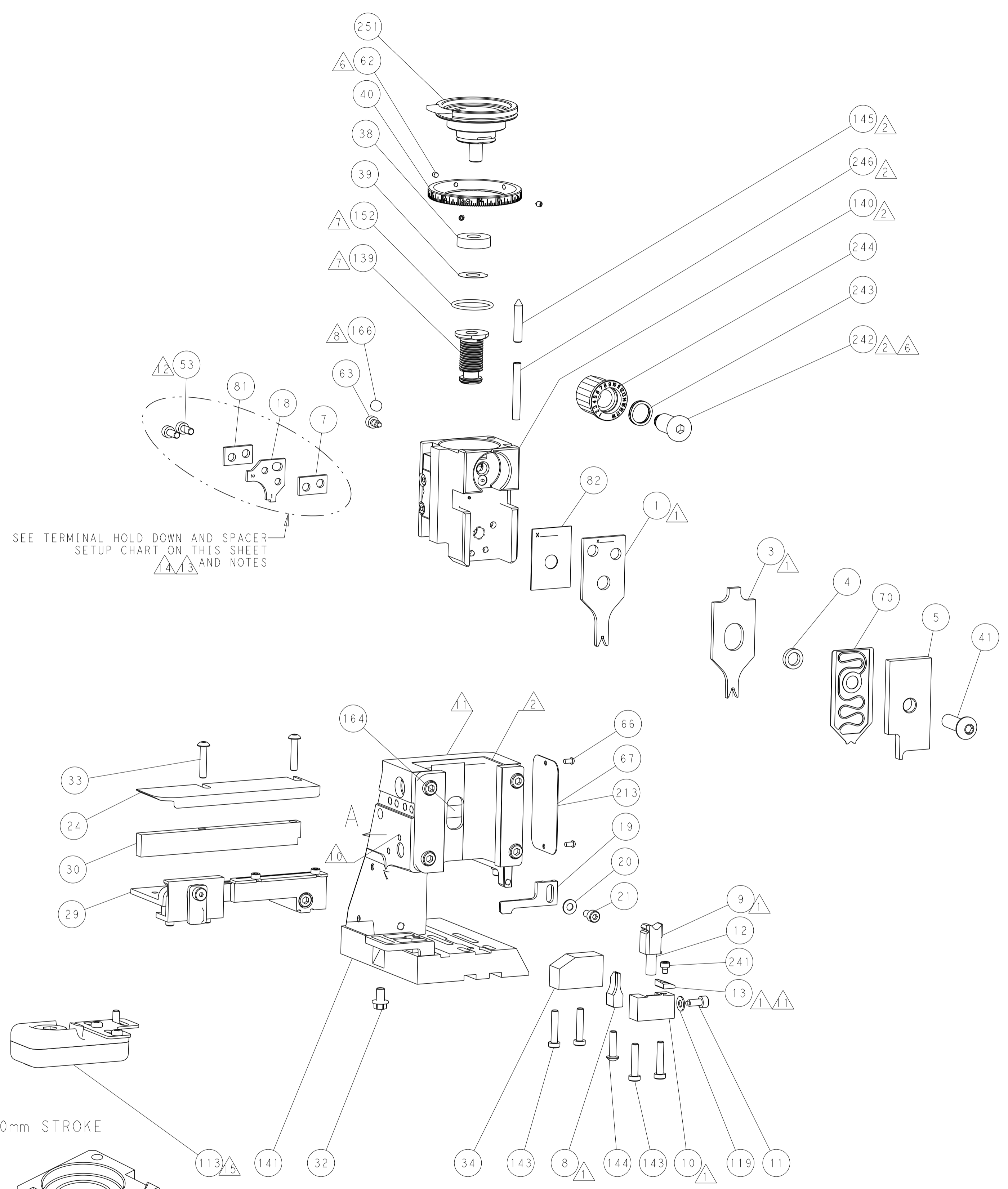
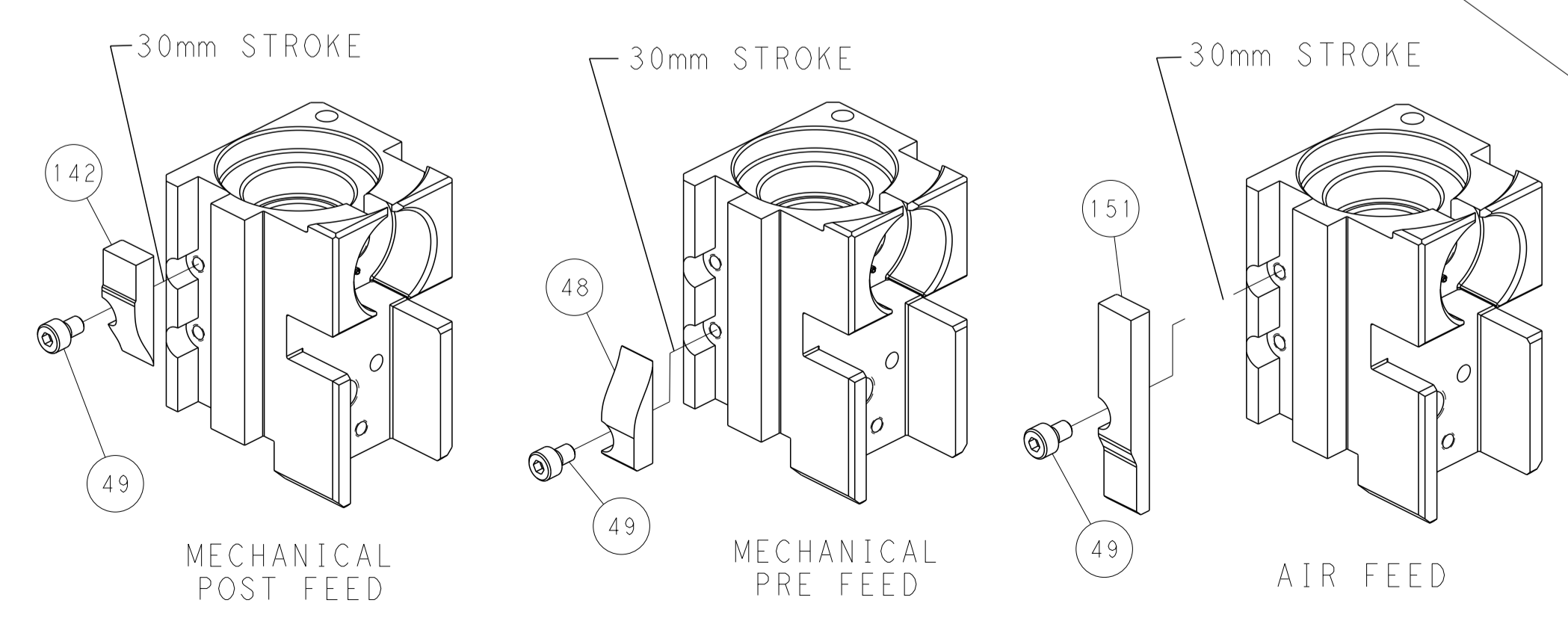

SEE TERMINAL HOLD DOWN AND SPACER SETUP CHART ON THIS SHEET AND NOTES

TERMINAL HOLD DOWN & SPACER SETUP CHART	
<b>GROUP 1</b> HOLD DOWN & SPACER TOOLING SETUP FOR TERMINALS: 963715-1 963716-1 963715-5 963716-2 963715-6 1-963716-2 1-963715-5 5-963716-1 5-963715-1 5-963716-2 5-963715-5 5-963716-3 5-963715-6 6-963716-1 6-963715-5 6-963716-2 1801529-1 1703298-1 1801529-2 1703298-5 2141399-6 2005120-1	 POSITION 1
HOLD DOWN & SPACER TOOLING SETUP FOR TERMINALS: 1452013-1 1-1452013-1 5-1452013-1 6-1452013-1	 POSITION 1
<b>GROUP 2</b> HOLD DOWN & SPACER TOOLING SETUP FOR TERMINALS: 968221-1 1703282-1 968221-5 1703282-2 968221-6 5-1703282-1 5-968221-1 5-1703282-2 5-968221-5 1379418-1 5-968221-6 1379418-2	 POSITION 2
HOLD DOWN & SPACER TOOLING SETUP FOR TERMINALS: 1241920-1 5-1241920-1	 POSITION 2

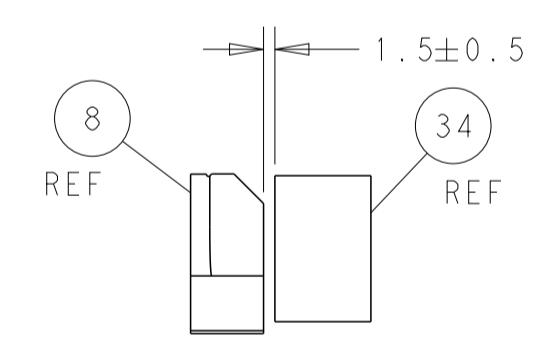

TERMINAL SUPPORT LOCATION

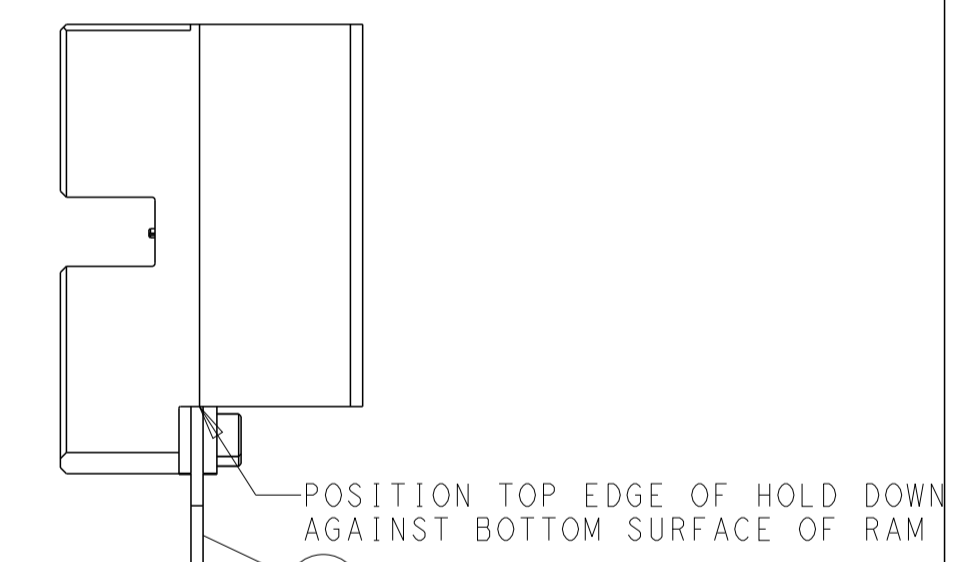

HOLD DOWN SETUP

ITEM 30 LOCATED AT FRONT HOLES

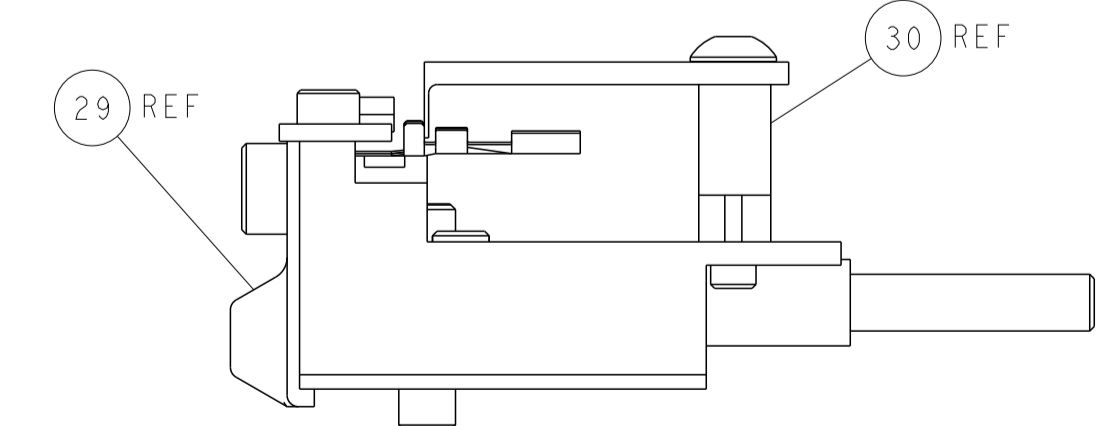

FEED TRACK POSITION GUIDE BY INSULATION BARREL

**PACIFIC VERSION**  
 Shown on sheets 3 of 4 & 4 of 4  
 (Atlantic version shown on sheets 1 of 4 & 2 of 4)

DIMENSIONS: mm 		TOLERANCES UNLESS OTHERWISE SPECIFIED: 0 PLC ± 1 PLC ± 2 PLC ± 3 PLC ± 4 PLC ± ANGLES ± FINISH		DWN B. WEAVER 31AUG2011 CHK G. HOFFNER 31AUG2011 APVD T. ELBIN 31AUG2011 PRODUCT SPEC APPLICATION SPEC WEIGHT Customer Accessible Production Drawing		NAME Ocean Side Feed Applicator SIZE CAGE CODE DRAWING NO A1 00779 C=2151491 SCALE 1:2 SHEET 4 OF 4 REV M	
--------------------	--	---	--	--	--	--	--