

ASSY NO.	MS NO.	DIMENSIONS										
		A +.050 -.060	B THREAD (PLATED) CLASS 2A	C ±.031	D MIN FULL THD	E +.010 -.000	F +.020 -.010	G +.000 -.010	H DIA +.010 -.000	J ±.005	K	L DIA +.004 -.002
10-168208-	3102 8S-	.422	5000-28 UNEF	.484	.391	.562	.672	.297	.375	.594	.875	.120
10-168210-	10S-		.6250-24 NEF						.500	.719	1.000	
10-168211-	10SL-		.6250-24 NEF						.625	.719	1.000	
10-168212-	12S-		.7500-20 UNEF		.450				.625	.812	1.094	
10-168213-	12-	.672	.7500-20 UNEF		.625	.750	.860	.484	.625	.812	1.094	
10-168214-	14S-	.422	.8750-20 UNEF	.484	.450	.562	.672	.297	.750	.906	1.188	
10-168215-	14-	.672	.8750-20 UNEF		.625	.750	.860	.484	.750	.906	1.188	
10-168216-	16S-	.422	1.0000-20 UNEF	.484	.450	.562	.672	.297	.875	.969	1.281	
10-168217-	16-	.672	1.0000-20 UNEF		.625	.750	.860	.484	.875	.969	1.281	
10-168218-	18-	.641	1.1250-18 NEF				.891	.453	1.000	1.062	1.375	
10-168220-	20-		1.2500-18 NEF						1.125	1.156	1.500	
10-168222-	22-		1.3750-18 NEF						1.250	1.250	1.625	
10-168224-	24-	.578	1.5000-18 NEF			.812	.953		1.375	1.375	1.750	.147
10-168228-	28-	.578	1.7500-18 NS			.812	.953		1.625	1.562	2.000	.147
10-168232-	32-	.500	2.0000-18 NS			.875	1.031	.438	1.875	1.750	2.250	.173
10-168236-	36-		2.2500-16 UN						2.062	1.938	2.500	
10-168240-	40-		2.5000-16 UN						2.312	2.188	2.750	

ACCESSORY
(NOT PART OF STANDARD ASSEMBLY)

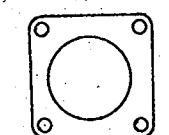

FLANGE GASKET,
PLAIN
10-40450-(SHELL SIZE)

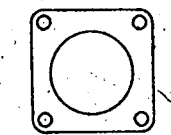

FLANGE GASKET,
SHIELDING
10-40450-(SHELL SIZE) S

REV	DATE	D'N	APPRO
1	3-7-56		MOORE
2	3-8-56		REV. "C" COLUMN
A1	3-20-56		.188(16M), .250(12) & .500(4) (SOLDER WELL DEPTH); REM SOLDER WELL DATA FOR 16
A2	3-17-60		REM PD COL (8 THD); REV NOTE 2; ADD NOTE 10
A3	10-26-63		MIL-C-5015C (NOTES 8 & 6)
A4	11-17-69		REM NOTE 9, REVISION LETTER (C) (3 PLACES)
A5	1-6-72		ADD. 9-3895 (PRO SPEC) REV STAMPING NOTE
A6	3-13-73		REV STAMPING EX (REM (C))

8. ALL 10- & 61-ASSEMBLIES TO BE ASSEMBLED PER 9-3103-1 & TESTED PER 9-3106-5. SUCH UNITS MEET THE REQUIREMENTS OF MS3102A PER MIL-C-5015D. INSERTS & CONTACTS ARE REMOVABLE.
7. SEE WORK ORDER FOR PERMISSIBLE ADDITIONAL OR ALTERNATE STAMPING.
6. ALL 62-ASSEMBLIES TO BE ASSEMBLED PER 9-3238-1 & TESTED PER 9-3106-4, SUCH UNITS MEET THE PERFORMANCE REQUIREMENTS OF MS3102C PER MIL-C-5015D. INSERTS & CONTACTS ARE NOT REMOVABLE.
5. SEE DRAWINGS 10-168608 THRU 10-168640 & DRAWINGS 10-168808 THRU 10-168840 FOR MATING PLUG ASSEMBLIES.
4. TO COMPLETE ASSEMBLY NUMBER & MS NO., ADD APPLICABLE INSERT ARRANGEMENT SUFFIX TO BASE NUMBERS LISTED ABOVE (FOR ALTERNATE ARRANGEMENTS, REFER TO 9-2437). TO DETERMINE DESIRED INSERT ARRANGEMENT, SEE PARTS LIST 10-168208 THRU 10-168240.
3. INCREASE A, DIMENSION BY .312 FOR SIZE "O" CONTACT ONLY.
2. FOR CONTACT SIZE, SPACING & SERVICE RATING, SEE DRAWINGS MS33680 THRU MS33690.
1. DIMENSIONS MUST BE MAINTAINED WHEN INSERTS ARE PRESSED FIRMLY AGAINST INDICATED SHOULDER.

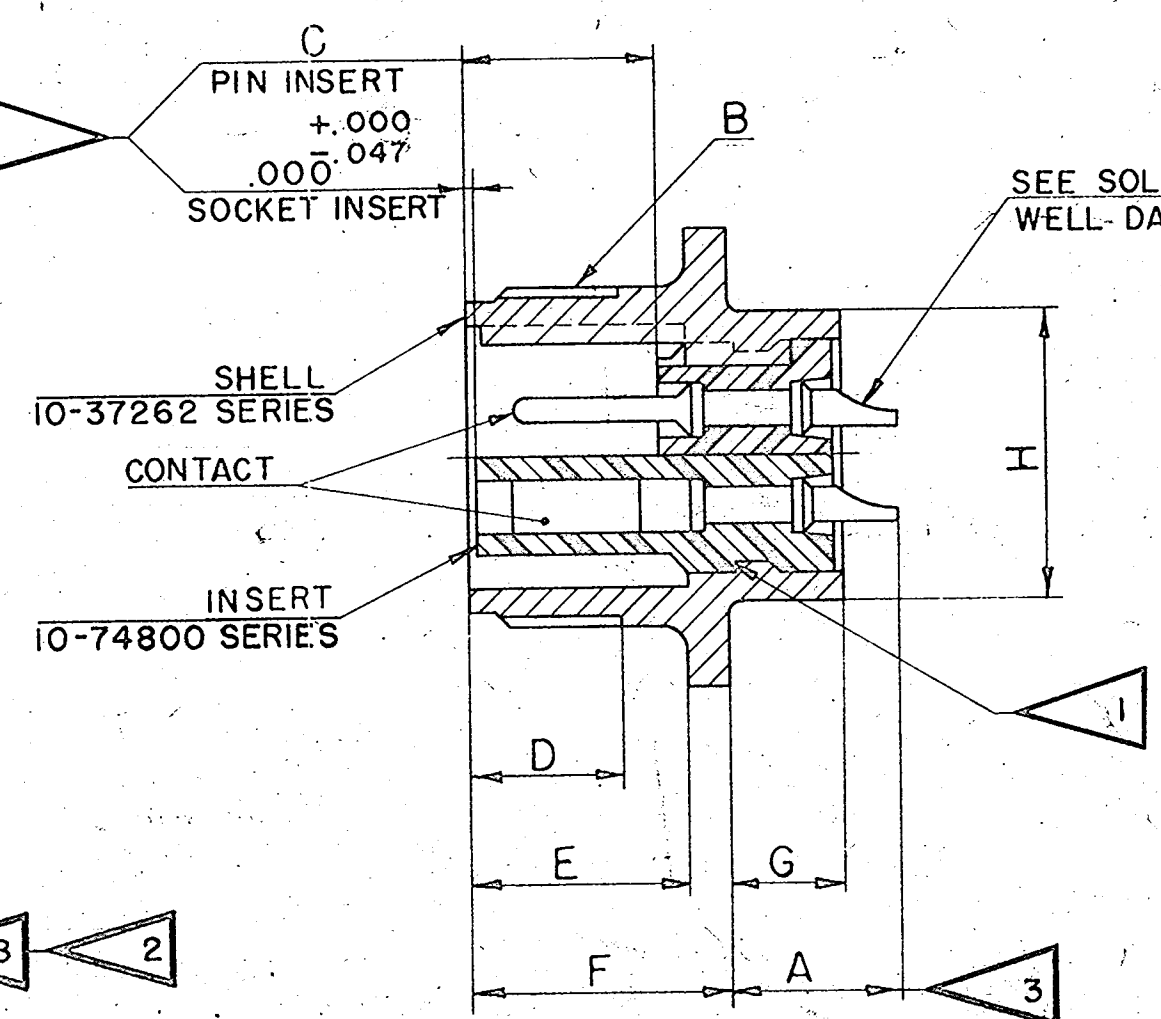
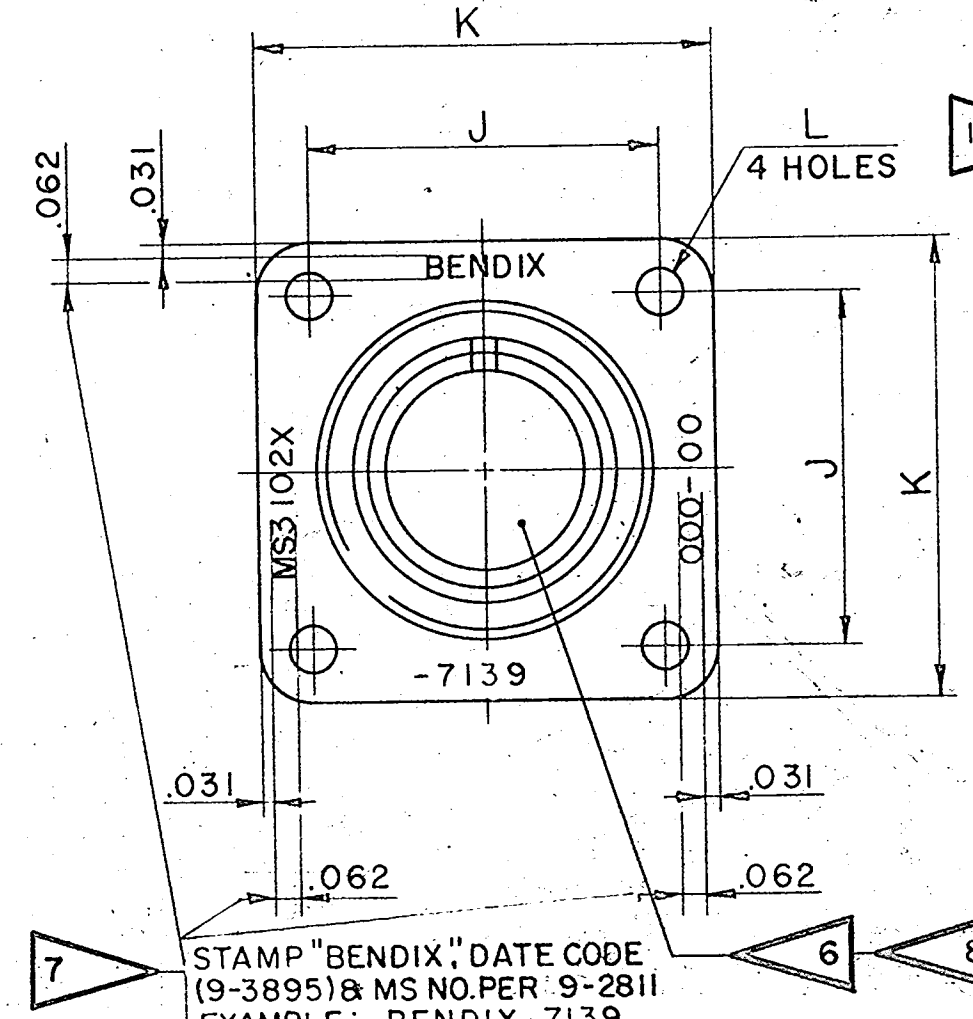

STAMP "BENDIX," DATE CODE (9-3895) & MS NO. PER 9-2811
 EXAMPLE: BENDIX -7139
 MS3102C20-12S OR MS3102A20-12S
 FOR SUFFIX OTHER THAN "P" OR "S",
 STAMPING TO BE IN ACCORDANCE WITH
 9-2437 (SUFFIX OF MS NO. ONLY)
 EXAMPLE: MS3102A20-12SX
 BENDIX -7139

10-168208 THRU
10-168240

USE OF THIS DOCUMENT IS UNLIMITED. DOCUMENTS REFERENCED HEREON CONTAIN LIMITED RIGHTS DATA.

SOLDER WELL DATA					
CONTACT SIZE	0	4	8	12	16M
WELL DIA	469 ⁺⁰⁰⁵ ₋₀₀₃	332 ⁺⁰⁰⁵ ₋₀₀₃	209 ⁺⁰⁰⁴ ₋₀₀₂	116 ⁺⁰⁰⁴ ₋₀₀₂	078 ⁺⁰⁰⁴ ₋₀₀₂
WELL DEPTH	625	625	500	375	250

NOTES: REF SYMBOL

10. FOR PART NUMBERS 10-168217-13, 10-168218-15, 61- & 62-, SEE INDIVIDUAL DRAWINGS 10-168217-13, 10-168218-15, 61-00000 & 62-00000.

SGINTILLA MAGNETO DIVISION
 REPAIR DIVISION OF OPERATIONAL UNIT
 HUNTSVILLE, ALA.

CONNECTOR, ELECTRICAL RECEPTACLE,
 TYPE (C) (FB)

D'N	CHECKER	MAT	ST'DS	CH'D'N	APPROVED	SCALE
S.GREER	Balantr					NONE
4-24-57	8-9-57					

10-168208 THRU
10-168240

DWG SIZE C