

M SERIES CONNECTORS
RATCHET COUPLING

M SERIES

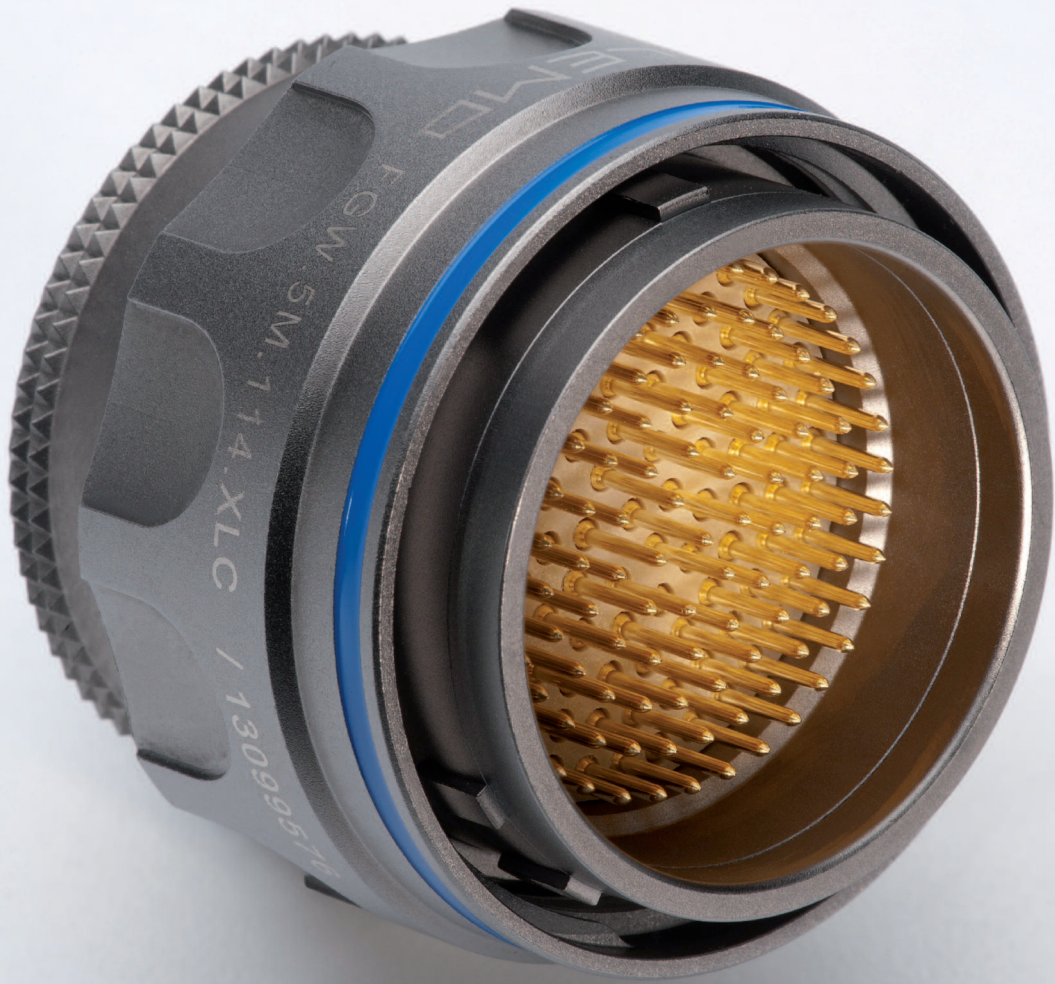

 **LEMO**



Introduction

This catalogue gives the complete description of LEMO M series connectors. M series connectors are lightweight triple-start ratchet coupling type connectors designed for avionics, aerospace, military, security, motorsport and heavy duty applications.

The LEMO manufacturing programme has been extended to almost 40 series divided into 7 product families with specific mating and environmental characteristics. Each series includes a wide variety of plug, socket and coupler models, available in contact configurations adapted to all round cables. Watertight models are also available. Since LEMO connectors are perfectly screened and designed to guarantee very low resistance to shell electrical continuity, they are particularly adapted to applications where electromagnetic compatibility (EMC) is important.

Technical Characteristics

Materials and Treatments

Component	Shell material code			Material (Standard)	Surface treatment (µm)			Notes	
	I	X	C		chrome	nickel			gold
						I	X		
Outer shell				Brass (UNS C 38500)	0.3	-	-	-	
				Aluminium alloy (AA 6262A or AA 6023)	-	14	5	-	1)
Conical nut				Brass (UNS C 38500)	0.3	-	-	-	
				Aluminium alloy (AA 6262A or AA 6023)	-	14	5	-	1)
Earthing crown				Bronze (UNS C 54400) or special brass	-	-	-	1.5	
Coupling nut				Brass (UNS C 38500)	-	-	3	-	-
				Aluminium alloy (AA 6262A or AA 6023)	-	14	3	-	1)
Ratchet				Special PEEK	-				
Hexagonal nut				Brass (UNS C 38500)	-	-	3	-	
				Aluminium alloy (AA 6262A or AA 6023)	-	-	5	-	
Male crimp contact				Brass (UNS C 34500)	-	-	-	1.0	-
Female crimp contact				Bronze (UNS C 54400)	-	-	-	1.5	-
Clips				Cu-Be or special steel	without treatment				
Insulator				PEEK	-				
O-ring				Silicone	-				
				FPM/FKM (Viton®)	-				
Sealing resin				Epoxy (Araldite® or Stycast®)	-				
Cable rear seal				Fluorosilicone	-				
Spring				Stainless steel	-				

Notes: standards for surface treatment are as follows: chrome-plated SAE AMS 2460; nickel-plated SAE AMS QQ N 290 or MIL DTL 32119; gold-plated ISO 27874. ¹⁾anthracite colour.

Environmental performance

Characteristics	Value	IEC international	MIL-spec tests
Operating temperature (mated)	-55°C/+200°C (HE● model: -20°C/+80°C)		
Ingress protection index	IP 68 (at 2 m, 15Hr)	IEC 60529	
Fungus	Satisfied - by material analysis		MIL-STD 810F-508.5
Flammability	60 sec. front and back face		EIA-364-104A
Fluid contamination ¹⁾	Fuels, gasoline, hydraulic oils, solvents, de-icing		MIL-STD-810F method 504
Sand and dust ²⁾	6 hr, 55°C, blowing < 150 µm dust		MIL-STD 810F-510.4
Lightning strike	10 K amps - 6 times		EIA-364-75
Altitude-low temp ³⁾	-65°C; 40'000 feet and 400 VAC		EIA-364-105A
Salt fog ⁴⁾	Alum. shell (up to 500Hr), Brass shell (1000Hr)	IEC 60512-6 test 11f	EIA-364-26
Thermal shock	5 cycles: -65°C to +150°C	IEC 60512-11-4	EIA-364-32 test condition IV
Altitude immersion	No moisture on contacts		EIA-364-03
Humidity	21 days at 95%	IEC 60068-2	EIA-364-31 method IV

Note: ¹⁾ Connectors immersed at both 70°C and 25°C according to specification. Connectors are then inspected, no visual signs of damage seen.

Fuels: Kerosene, JP4, (Nato F40) at 70°C +/- 2°C. Gasoline: ASTM 4814. Hydraulic oils: Mineral oil based MIL-H-5606.

Solvents: Isopropanol. De-icing fluids: 25% ethylene glycol.

²⁾ No signs of damage, connectors opened and closed without difficulty. Dust or sand was not inside connector.

³⁾ Wired mated connectors = no voltage breakdown, shell to all contacts (connected together) w/400 VAC after 1 hour at 65°C at 40'000 feet altitude.

⁴⁾ Corrosion resistance. Inspection: salt deposits shall be removed by gentle wash in running water with light brushing using soft brush.

Aluminium Shell (material code: X) max: 48 hours, (material code: I) max: 500 hours. Brass shell (material code: C) over 1000 hours.

DISCLAIMER The information contained within this catalog and the functions offered are intended to provide information about products. All reasonable efforts have been made to ensure the accuracy of the information. However, LEMO cannot be held responsible for any errors. LEMO does not warrant the accuracy and reserves the right to make changes to the catalog and its functions at any time without notice.

Electrical performance

Characteristics	Value	IEC international	MIL-spec tests
Insulation resist. (at ambient temp.) ⁶⁾	> 10 ¹² Ω, > 10 ¹⁰ Ω (after humidity)	IEC 60512-2 test 3a	EIA-364-21
Dielectric withstanding volt. (sea level)	See table page 22-23-24	IEC 60512-2 test 4a	EIA-364-20
Contact resistance	See table below ⁷⁾	IEC 60512-2 test 2a	EIA-364-06
Current rating	See insulator configuration page 22-23-24	IEC 60512-3 test 5a	
Shell to shell conductivity	< 1.5 mΩ	IEC 60512-2-6	EIA-364-83
Shielding effectiveness, low frequency	≥ 80 dB up to 1GHz		EIA-364-66
Shielding effectiveness, high frequency	≥ 70 dB (3GHz), ≥ 58 dB (6GHz), ≥ 40 dB (10GHz)		EIA-364-66

Note: ⁶⁾ After humidity test: 21 days at 95% RH according to IEC 60068-2. Insulation resistance measured between the contacts and contact/shell.

Contact resistance ⁷⁾ IEC 60512-2 test 2a				Value
0.5	0.7	0.9	1.3	∅ A (mm)
≤ 8.7	≤ 6.1	≤ 4.8	≤ 3.6	mΩ

Notes: ⁷⁾ after 5000 mating cycles and the salt spray test according to IEC 60512-6 test 11 f.

Mechanical performance

Characteristics	Value	IEC international	MIL-spec tests
Endurance	3000 cycles	IEC 60512-5 test 9a	EIA-364-09
Gunfire vibration	25 to 2000 Hz, 3 axis (Apache helicopter)		MIL-STD-810F method 519.5
Vibration-Sine ⁸⁾	30 g, 3 axis, 12 hr		MIL-STD-202 method 204-G
Vibration-Random	50-2000 Hz, 37.8 g rms-3 axes; 4h amb	IEC 60512-6-4	EIA-364-28 test cond. V letter I
Shock	300 g - 3 msec	IEC 60512-6-3	EIA-364-27 condition D
Acceleration	50 g acceleration		MIL-STD-1344 - 2011-1, A
Contact retention	> 22 N (∅ 0.7 mm), > 30 N (∅ 0.9 mm)	IEC 60512-8 test 15a	
Torque	See table below		

Note: ⁸⁾ Amplitude: 30G. Frequency: 10 to 2000 Hz. Time per axis: 4 hours (X, Y, Z). No signal discontinuity above 1 μs.

Series	Coupling torque tightning (N.cm)	Coupling torque untightning (N.cm)	Series	Coupling torque tightning (N.cm)	Coupling torque untightning (N.cm)
MM	8	4	TM	26	30
OM	4	5	4M	26	25
1M	10	11	LM	48 ⁹⁾	43
2M	20	14	5M	91 ⁹⁾	54
3M	34	29			

Note: ⁹⁾ Higher contact density = larger torque force.

M Series

The M Series connector offers a new innovative design for avionics, aerospace, military, security, motorsport and heavy duty applications.

Made of high-strength aluminium, this connector is one of the lightest and most compact of the LEMO product line. A one-grip ratchet screw system enables quick and secure coupling of the connectors. The arctic grip makes it easy to manipulate the connector while wearing gloves or when the connector is located in a difficult to access area.

Features

- Ratchet-coupling mechanism
- Compact design for space savings
- Oil and fuel resistant
- 360° screening for full EMC shielding
- Colour coding / keying
- Scoop proof
- Threaded for MIL-DTL-38999L backshell
- Quick mating: less than 3/4 turn to seat
- Lightweight
- High vibration and shock resistance
- Sealed to IP68 when mated
- Reverse gender configuration
- Pin configuration from 2 to 114 contacts

Metal housing models (page 5)

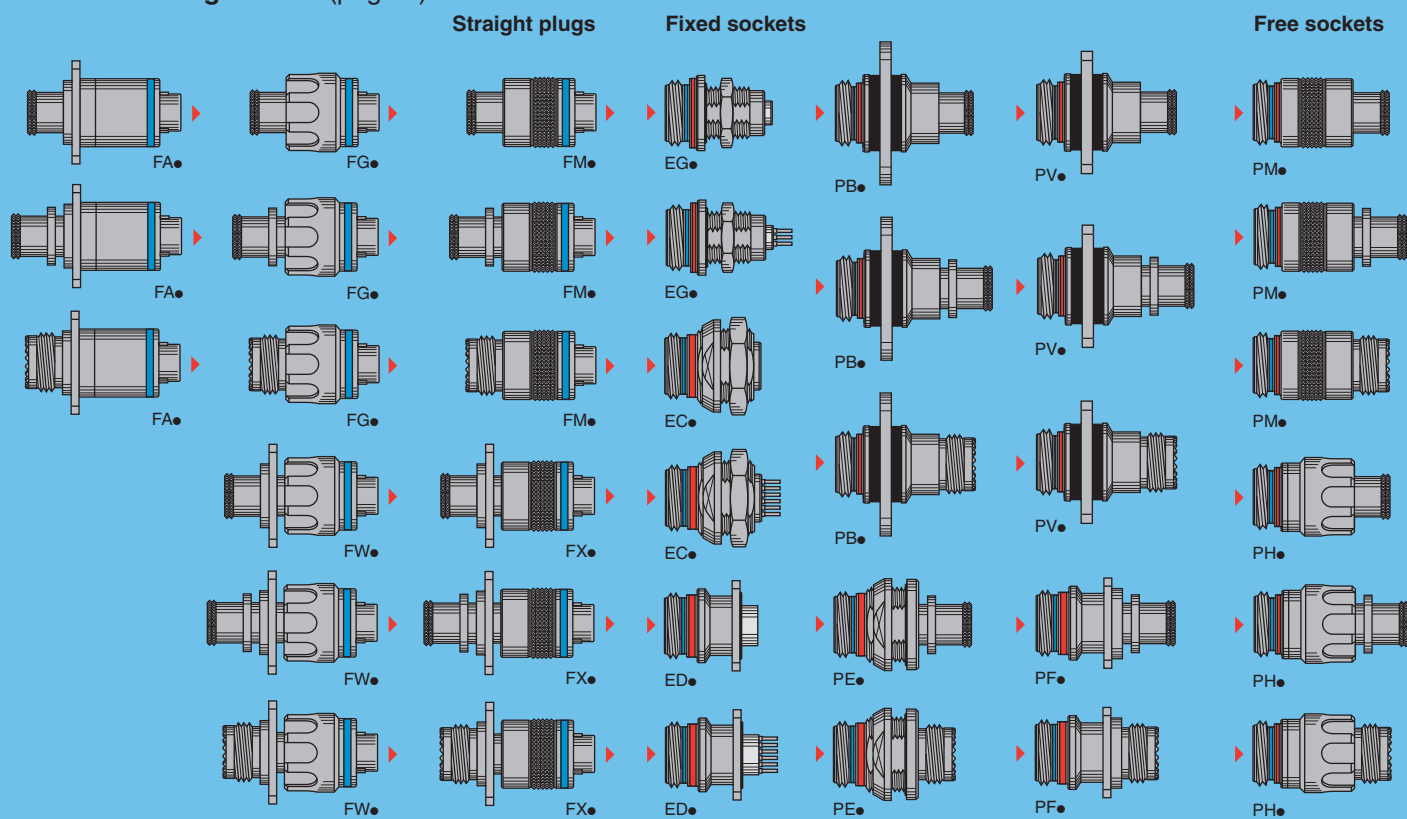

USB models (page 21)

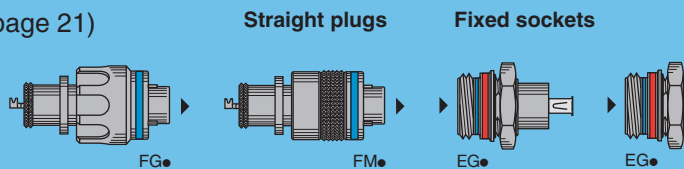

Watertight model (unmated)

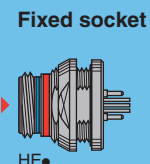

Fibre optic models (page 18)

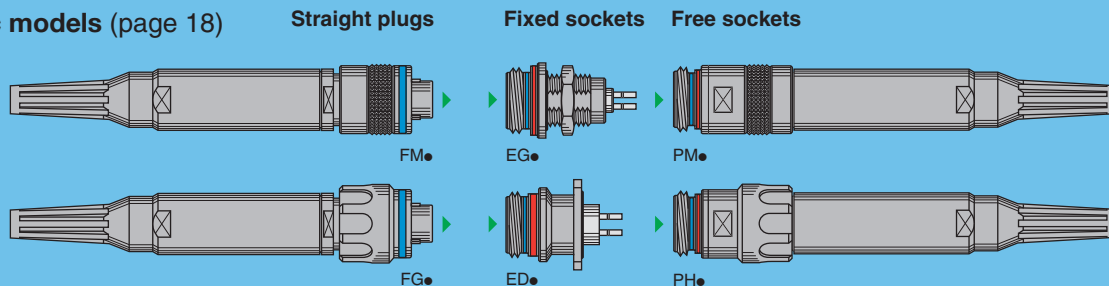

Part Numbering System

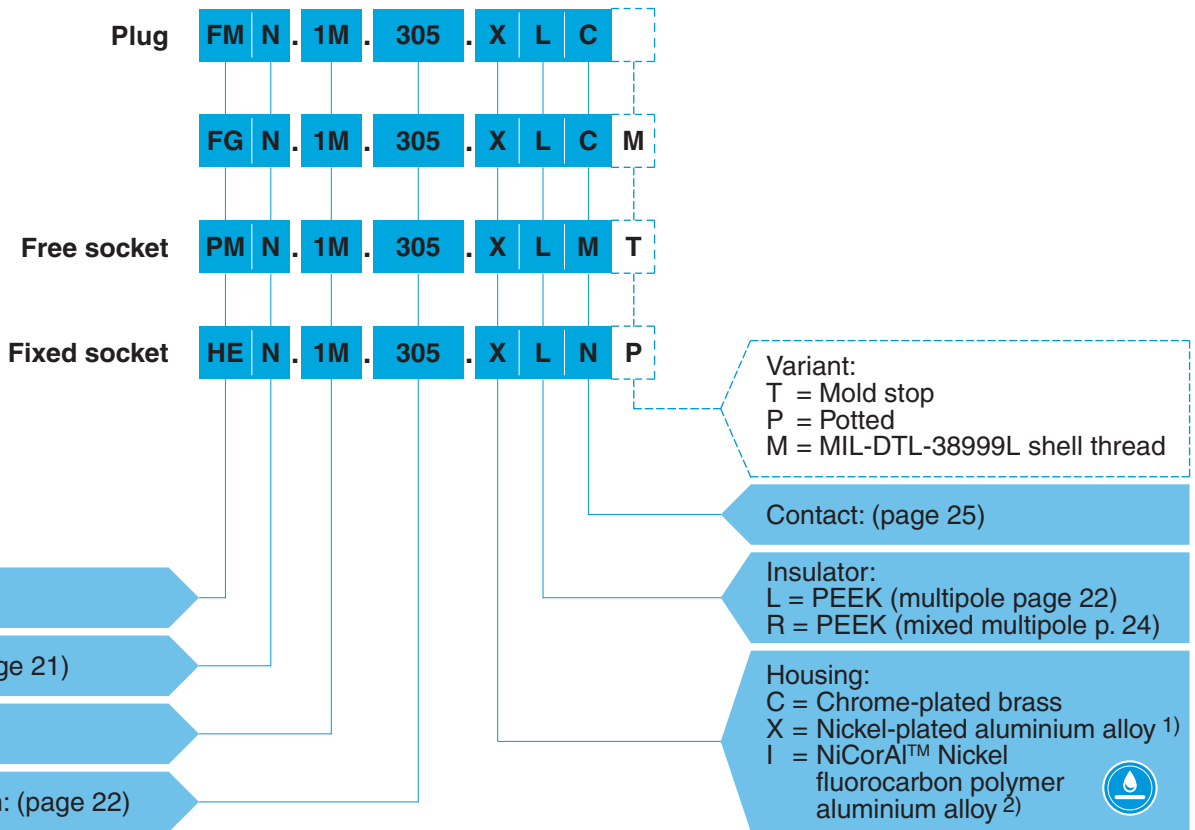

Part Number Example

Straight plug:

FMN.1M.305.XLC = straight plug with key (N), 1M series, multipole type with 5 contacts, outer shell in anthracite nickel-plated aluminium alloy, PEEK insulator, male crimp contacts.

Straight plug:

FGN.1M.305.XLCM = straight plug with key (N), arctic grip, 1M series, multipole type with 5 contacts, outer shell in anthracite nickel-plated aluminium alloy, PEEK insulator, male crimp contacts and with MIL-DTL-38999L thread for additional backshell (not supplied).

Free socket:

PMN.1M.305.XLMT = free socket with key (N), 1M series, multipole type with 5 contacts, outer shell in anthracite nickel-plated aluminium alloy, PEEK insulator, female crimp contacts and mold stop.

Fixed socket:

HEN.1M.305.XLNP = fixed socket, nut fixing, with key (N), 1M series, multipole type with 5 contacts, outer shell in anthracite nickel-plated aluminium alloy, PEEK insulator, female print contacts, watertight.

Note: ¹⁾ anthracite colour / 48 hours salt fog resistance. ²⁾ anthracite colour / 500 hours salt fog resistance RoHS 2/REACH.

Part Section Showing Internal Components

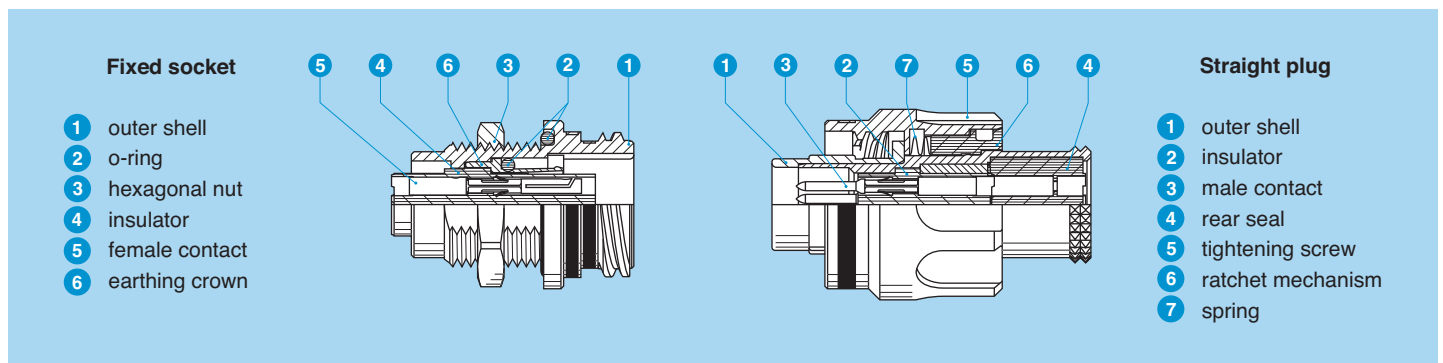



Metal housing models



FM● Straight plug, key (N) or keys (P, R, S, T, U, V, W and X) with knurled grip

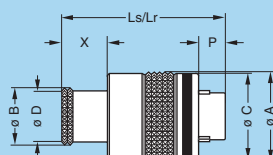

Reference		Dimensions (mm)							
Model	Series	A	B	C	D	Ls	Lr	P	X
FM●	MM	11.1	6.4	10.7	5.6	21.3	21.3	5.5	5.8
FM●	0M	13.1	8.8	12.7	8.0	24.1	24.1	3.9	6.7
FM●	1M	14.6	10.5	14.2	9.7	24.1	24.1	3.9	6.7
FM●	2M	17.6	14.0	17.2	13.0	24.5	24.5	3.9	7.1
FM●	3M	19.6	16.0	19.2	15.0	24.5	24.5	3.9	7.1
FM●	TM	22.5	17.9	22.0	16.7	28.6	28.6	3.4	7.6
FM●	4M	25.0	20.7	24.5	19.5	28.6	28.6	3.4	7.6
FM●	LM	28.5	23.9	28.0	22.7	28.6	28.6	3.4	7.6
FM●	5M	34.0	29.7	33.5	28.5	28.6	28.6	3.4	7.6

Part number example: FMN.1M.305.XLC

Note: Ls = standard gender, Lr = reverse gender



FM● Straight plug, key (N) or keys (P, R, S, T, U, V, W and X) with knurled grip and mold stop

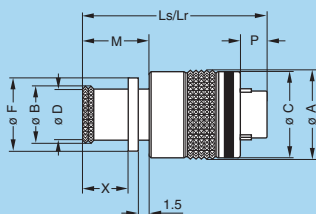

Reference		Dimensions (mm)									
Model	Series	A	B	C	D	F	Ls	Lr	M	P	X
FM●	MM	11.1	6.4	10.7	5.6	7.8	24.3	24.3	8.8	5.5	5.8
FM●	0M	13.1	8.8	12.7	8.0	10.7	27.1	27.1	9.7	3.9	6.7
FM●	1M	14.6	10.5	14.2	9.7	12.4	27.1	27.1	9.7	3.9	6.7
FM●	2M	17.6	14.0	17.2	13.0	15.5	27.5	27.5	10.1	3.9	7.1
FM●	3M	19.6	16.0	19.2	15.0	17.5	27.5	27.5	10.1	3.9	7.1
FM●	TM	22.5	17.9	22.0	16.7	19.8	31.6	31.6	10.6	3.4	7.6
FM●	4M	25.0	20.7	24.5	19.5	22.6	31.6	31.6	10.6	3.4	7.6
FM●	LM	28.5	23.9	28.0	22.7	25.8	31.6	31.6	10.6	3.4	7.6
FM●	5M	34.0	29.7	33.5	28.5	31.4	31.6	31.6	10.6	3.4	7.6

Part number example: FMN.1M.305.XLCT

Note: Ls = standard gender, Lr = reverse gender



FM● Straight plug, key (N) or keys (P, R, S, T, U, V, W and X) with knurled grip and MIL-DTL-38999L shell thread

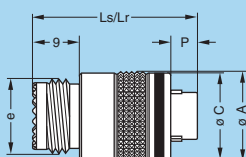

Reference		Dimensions (mm)						
Model	Series	A	C	e	Ls	Lr	P	Code ¹⁾
FM●	1M	14.6	14.2	M12x1.0	26.4	26.4	3.9	A
FM●	2M	17.6	17.2	M15x1.0	26.4	26.4	3.9	B
FM●	3M	19.6	19.2	M18x1.0	26.4	26.4	3.9	C
FM●	TM	22.5	22.0	M18x1.0	30.0	30.0	3.4	C
FM●	4M	25.0	24.5	M22x1.0	30.0	30.0	3.4	D
FM●	LM	28.5	28.0	M25x1.0	30.0	30.0	3.4	E
FM●	5M	34.0	33.5	M31x1.0	30.0	30.0	3.4	G

Part number example: FMN.1M.305.XLCM

Note: Ls = standard gender, Lr = reverse gender. ¹⁾ MIL-DTL-38999L shell size code (backshell not supplied).

DISCLAIMER The information contained within this catalog and the functions offered are intended to provide information about products. All reasonable efforts have been made to ensure the accuracy of the information. However, LEMO cannot be held responsible for any errors. LEMO does not warrant the accuracy and reserves the right to make changes to the catalog and its functions at any time without notice.

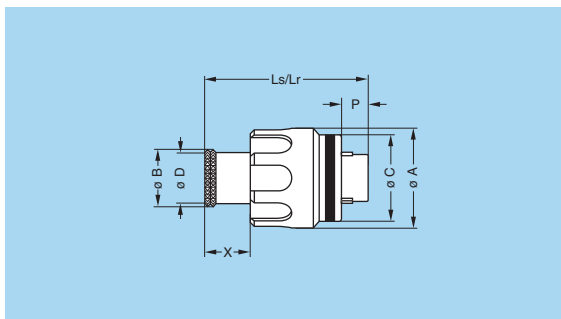

FG● Straight plug, key (N) or keys (P, R, S, T, U, V, W and X) with arctic grip

Reference		Dimensions (mm)							
Model	Series	A	B	C	D	Ls	Lr	P	X
FG●	MM	12.0	6.4	10.7	5.6	21.3	21.3	5.5	5.8
FG●	0M	14.4	8.8	12.7	8.0	24.1	24.1	3.9	6.7
FG●	1M	15.9	10.5	14.2	9.7	24.1	24.1	3.9	6.7
FG●	2M	18.9	14.0	17.2	13.0	24.5	24.5	3.9	7.1
FG●	3M	20.9	16.0	19.2	15.0	24.5	24.5	3.9	7.1
FG●	TM	23.4	17.9	22.0	16.7	28.6	28.6	3.4	7.6
FG●	4M	25.9	20.7	24.5	19.5	28.6	28.6	3.4	7.6
FG●	LM	29.4	23.9	28.0	22.7	28.6	28.6	3.4	7.6
FG●	5M	34.9	29.7	33.5	28.5	28.6	28.6	3.4	7.6

Part number example: FGN.1M.305.XLC

Note: Ls = standard gender, Lr = reverse gender

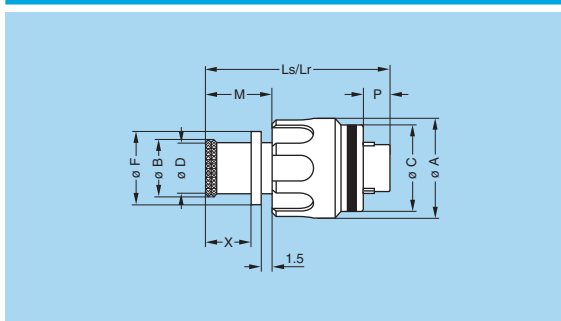

FG● Straight plug, key (N) or keys (P, R, S, T, U, V, W and X) with arctic grip and mold stop

Reference		Dimensions (mm)									
Model	Series	A	B	C	D	F	Ls	Lr	M	P	X
FG●	MM	12.0	6.4	10.7	5.6	7.8	24.3	24.3	8.8	5.5	5.8
FG●	0M	14.4	8.8	12.7	8.0	10.7	27.1	27.1	9.7	3.9	6.7
FG●	1M	15.9	10.5	14.2	9.7	12.4	27.1	27.1	9.7	3.9	6.7
FG●	2M	18.9	14.0	17.2	13.0	15.5	27.5	27.5	10.1	3.9	7.1
FG●	3M	20.9	16.0	19.2	15.0	17.5	27.5	27.5	10.1	3.9	7.1
FG●	TM	23.4	17.9	22.0	16.7	19.8	31.6	31.6	10.6	3.4	7.6
FG●	4M	25.9	20.7	24.5	19.5	22.6	31.6	31.6	10.6	3.4	7.6
FG●	LM	29.4	23.9	28.0	22.7	25.8	31.6	31.6	10.6	3.4	7.6
FG●	5M	34.9	29.7	33.5	28.5	31.4	31.6	31.6	10.6	3.4	7.6

Part number example: FGN.1M.305.XLCT

Note: Ls = standard gender, Lr = reverse gender

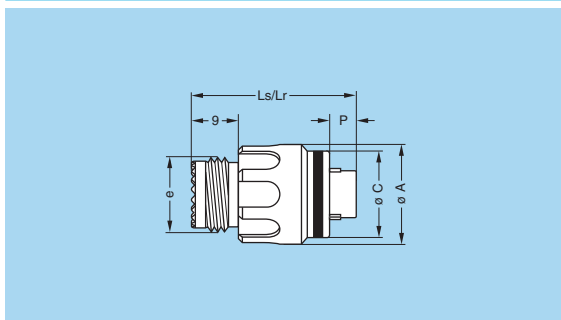

FG● Straight plug, key (N) or keys (P, R, S, T, U, V, W and X) with arctic grip and MIL-DTL-38999L shell thread

Reference		Dimensions (mm)						
Model	Series	A	C	e	Ls	Lr	P	Code ¹⁾
FG●	1M	15.9	14.2	M12x1.0	26.4	26.4	3.9	A
FG●	2M	18.9	17.2	M15x1.0	26.4	26.4	3.9	B
FG●	3M	20.9	19.2	M18x1.0	26.4	26.4	3.9	C
FG●	TM	23.4	22.0	M18x1.0	30.0	30.0	3.4	C
FG●	4M	25.9	24.5	M22x1.0	30.0	30.0	3.4	D
FG●	LM	29.4	28.0	M25x1.0	30.0	30.0	3.4	E
FG●	5M	34.9	33.5	M31x1.0	30.0	30.0	3.4	G

Part number example: FGN.1M.305.XLCM

Note: Ls = standard gender, Lr = reverse gender. ¹⁾ MIL-DTL-38999L shell size code (backshell not supplied).

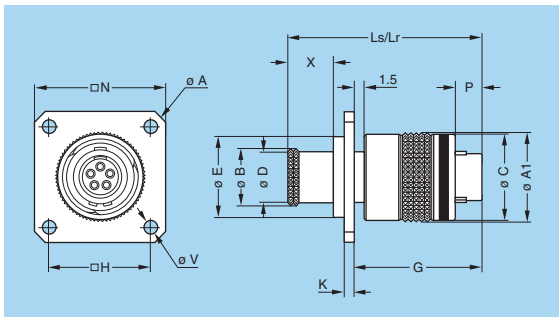

FX● Straight plug with square flange, key (N) or keys (P, R, S, T, U, V, W and X) with knurled grip

Reference		Dimensions (mm)												
Model	Series	A	A1	B	C	D	E	G	H	K	Ls	Lr	N	V
FX●	MM	21.5	11.1	6.4	10.7	5.6	9.5	17.0	12.0	1.5	26.1	26.1	17.0	2.7
FX●	0M	26.9	13.1	8.8	12.7	8.0	12.2	18.9	15.1	1.5	29.1	29.1	20.6	2.7
FX●	1M	31.4	14.6	10.5	14.2	9.7	13.7	18.9	18.3	1.5	29.1	29.1	23.8	3.3
FX●	2M	34.6	17.6	14.0	17.2	13.0	16.7	18.9	20.6	1.5	29.5	29.5	26.1	3.3
FX●	3M	34.6	19.6	16.0	19.2	15.0	18.7	18.9	20.6	1.5	29.5	29.5	26.1	3.3
FX●	TM	38.0	22.5	17.9	22.0	16.7	21.5	22.5	23.0	2.0	34.8	34.8	28.5	3.3
FX●	4M	40.3	25.0	20.7	24.5	19.5	24.0	22.5	24.6	2.0	34.8	34.8	30.1	3.3
FX●	LM	43.7	28.5	23.9	28.0	22.7	27.5	22.5	27.0	2.0	34.8	34.8	32.5	3.3
FX●	5M	47.0	34.0	29.7	33.5	28.5	33.0	22.5	29.4	2.0	34.8	34.8	37.0	3.3

Part number example: FXN.1M.305.XLC

Note: The dimensions «P» and «X» are the same as the FM● models. Ls = standard gender, Lr = reverse gender.

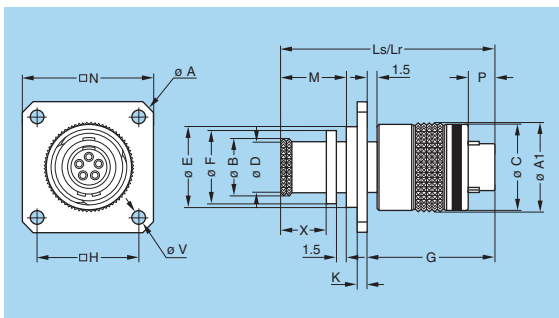

FX● Straight plug with square flange, key (N) or keys (P, R, S, T, U, V, W and X) with knurled grip and mold stop

Reference		Dimensions (mm)												
Model	Series	A	A1	B	C	D	E	G	H	K	Ls	Lr	N	V
FX●	MM	21.5	11.1	6.4	10.7	5.6	9.5	17.0	12.0	1.5	29.1	29.1	17.0	2.7
FX●	0M	26.9	13.1	8.8	12.7	8.0	12.2	18.9	15.1	1.5	32.1	32.1	20.6	2.7
FX●	1M	31.4	14.6	10.5	14.2	9.7	13.7	18.9	18.3	1.5	32.1	32.1	23.8	3.3
FX●	2M	34.6	17.6	14.0	17.2	13.0	16.7	18.9	20.6	1.5	32.5	32.5	26.1	3.3
FX●	3M	34.6	19.6	16.0	19.2	15.0	18.7	18.9	20.6	1.5	32.5	32.5	26.1	3.3
FX●	TM	38.0	22.5	17.9	22.0	16.7	21.5	22.5	23.0	2.0	37.8	37.8	28.5	3.3
FX●	4M	40.3	25.0	20.7	24.5	19.5	24.0	22.5	24.6	2.0	37.8	37.8	30.1	3.3
FX●	LM	43.7	28.5	23.9	28.0	22.7	27.5	22.5	27.0	2.0	37.8	37.8	32.5	3.3
FX●	5M	47.0	34.0	29.7	33.5	28.5	33.0	22.5	29.4	2.0	37.8	37.8	37.0	3.3

Part number example: FXN.1M.305.XLCT

Note: The dimensions «F», «M», «P» and «X» are the same as the FM● models. Ls = standard gender, Lr = reverse gender.

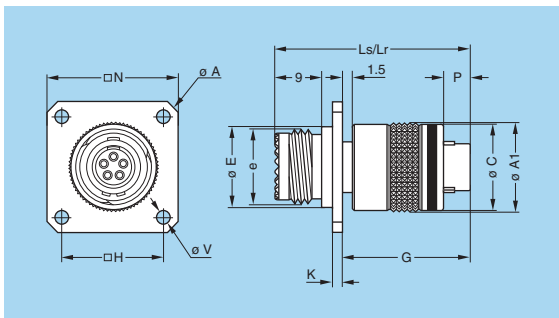

FX● Straight plug with square flange, key (N) or keys (P, R, S, T, U, V, W and X) with knurled grip and MIL-DTL-38999L shell thread

Reference		Dimensions (mm)										
Model	Series	A	A1	C	e	E	G	H	K	Ls	Lr	Code ¹⁾
FX●	1M	31.4	14.6	14.2	M12x1.0	13.7	18.9	18.3	1.5	31.4	31.4	A
FX●	2M	34.6	17.6	17.2	M15x1.0	16.7	18.9	20.6	1.5	31.4	31.4	B
FX●	3M	34.6	19.6	19.2	M18x1.0	18.7	18.9	20.6	1.5	31.4	31.4	C
FX●	TM	38.0	22.5	22.0	M18x1.0	21.5	22.5	23.0	2.0	36.2	36.2	C
FX●	4M	40.3	25.0	24.5	M22x1.0	24.0	22.5	24.6	2.0	36.2	36.2	D
FX●	LM	43.7	28.5	28.0	M25x1.0	27.5	22.5	27.0	2.0	36.2	36.2	E
FX●	5M	47.0	34.0	33.5	M31x1.0	33.0	22.5	29.4	2.0	36.2	36.2	F

Part number example: FXN.1M.305.XLCM

Note: The dimensions «N» and «V» are the same as the FX● models and the dimension «P» is the same as the FM● models. Ls = standard gender, Lr = reverse gender. ¹⁾ MIL-DTL-38999L shell size code (backshell not supplied).

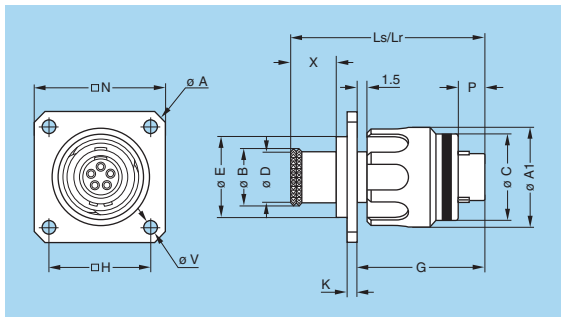
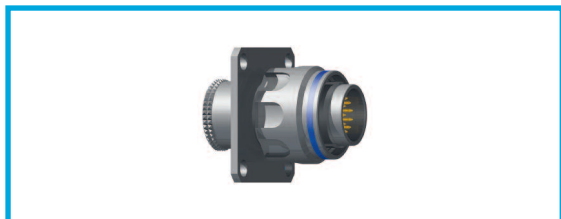

FW● Straight plug with square flange, key (N) or keys (P, R, S, T, U, V, W and X) with arctic grip

Reference		Dimensions (mm)												
Model	Series	A	A1	B	C	D	E	G	H	K	Ls	Lr	N	V
FW●	MM	21.5	12.0	6.4	10.7	5.6	9.5	17.0	12.0	1.5	26.1	26.1	17.0	2.7
FW●	0M	26.9	14.4	8.8	12.7	8.0	12.2	18.9	15.1	1.5	29.1	29.1	20.6	2.7
FW●	1M	31.4	15.9	10.5	14.2	9.7	13.7	18.9	18.3	1.5	29.1	29.1	23.8	3.3
FW●	2M	34.6	18.9	14.0	17.2	13.0	16.7	18.9	20.6	1.5	29.5	29.5	26.1	3.3
FW●	3M	34.6	20.9	16.0	19.2	15.0	18.7	18.9	20.6	1.5	29.5	29.5	26.1	3.3
FW●	TM	38.0	23.4	17.9	22.0	16.7	21.5	22.5	23.0	2.0	34.8	34.8	28.5	3.3
FW●	4M	40.3	25.9	20.7	24.5	19.5	24.0	22.5	24.6	2.0	34.8	34.8	30.1	3.3
FW●	LM	43.7	29.4	23.9	28.0	22.7	27.5	22.5	27.0	2.0	34.8	34.8	32.5	3.3
FW●	5M	47.0	34.9	29.7	33.5	28.5	33.0	22.5	29.4	2.0	34.8	34.8	37.0	3.3

Part number example: FWN.1M.305.XLC

Note: The dimensions «P» and «X» are the same as the FM● models.
Ls = standard gender, Lr = reverse gender.

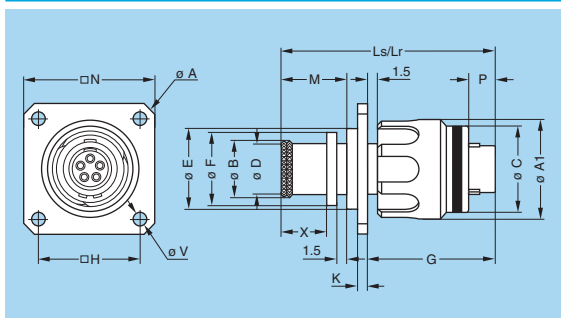

FW● Straight plug with square flange, key (N) or keys (P, R, S, T, U, V, W and X) with arctic grip and mold stop

Reference		Dimensions (mm)												
Model	Series	A	A1	B	C	D	E	G	H	K	Ls	Lr	N	V
FW●	MM	21.5	12.0	6.4	10.7	5.6	9.5	17.0	12.0	1.5	29.1	29.1	17.0	2.7
FW●	0M	26.9	14.4	8.8	12.7	8.0	12.2	18.9	15.1	1.5	32.1	32.1	20.6	2.7
FW●	1M	31.4	15.9	10.5	14.2	9.7	13.7	18.9	18.3	1.5	32.1	32.1	23.8	3.3
FW●	2M	34.6	18.9	14.0	17.2	13.0	16.7	18.9	20.6	1.5	32.5	32.5	26.1	3.3
FW●	3M	34.6	20.9	16.0	19.2	15.0	18.7	18.9	20.6	1.5	32.5	32.5	26.1	3.3
FW●	TM	38.0	23.4	17.9	22.0	16.7	21.5	22.5	23.0	2.0	37.8	37.8	28.5	3.3
FW●	4M	40.3	25.9	20.7	24.5	19.5	24.0	22.5	24.6	2.0	37.8	37.8	30.1	3.3
FW●	LM	43.7	29.4	23.9	28.0	22.7	27.5	22.5	27.0	2.0	37.8	37.8	32.5	3.3
FW●	5M	47.0	34.9	29.7	33.5	28.5	33.0	22.5	29.4	2.0	37.8	37.8	37.0	3.3

Part number example: FWN.1M.305.XLCT

Note: The dimensions «F», «M», «P» and «X» are the same as the FM● models.
Ls = standard gender, Lr = reverse gender.

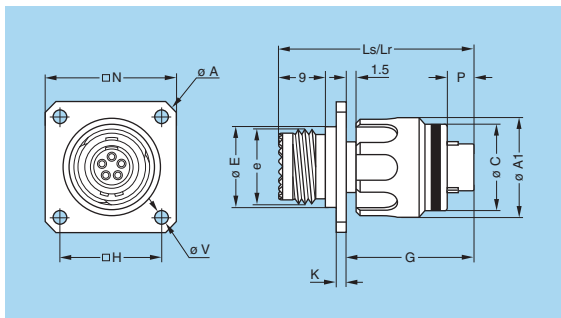

FW● Straight plug with square flange, key (N) or keys (P, R, S, T, U, V, W and X) with arctic grip and MIL-DTL-38999L shell thread

Reference		Dimensions (mm)										
Model	Series	A	A1	C	e	E	G	H	K	Ls	Lr	Code ¹⁾
FW●	1M	31.4	15.9	14.2	M12x1.0	13.7	18.9	18.3	1.5	31.4	31.4	A
FW●	2M	34.6	18.9	17.2	M15x1.0	16.7	18.9	20.6	1.5	31.4	31.4	B
FW●	3M	34.6	20.9	19.2	M18x1.0	18.7	18.9	20.6	1.5	31.4	31.4	C
FW●	TM	38.0	23.4	22.0	M18x1.0	21.5	22.5	23.0	2.0	36.2	36.2	C
FW●	4M	40.3	25.9	24.5	M22x1.0	24.0	22.5	24.6	2.0	36.2	36.2	D
FW●	LM	43.7	29.4	28.0	M25x1.0	27.5	22.5	27.0	2.0	36.2	36.2	E
FW●	5M	47.0	34.9	33.5	M31x1.0	33.0	22.5	29.4	2.0	36.2	36.2	F

Part number example: FWN.1M.305.XLCM

Note: The dimensions «N» and «V» are the same as the FW● models and the dimension «P» is the same as the FM● models. Ls = standard gender, Lr = reverse gender.
¹⁾ MIL-DTL-38999L shell size code (backshell not supplied).

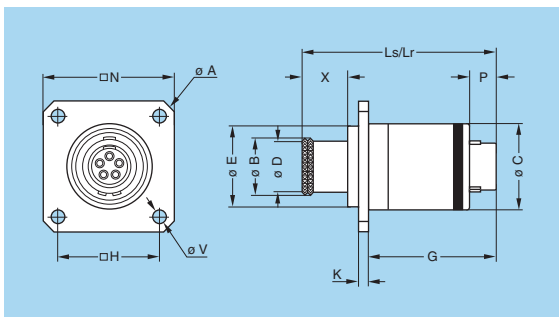
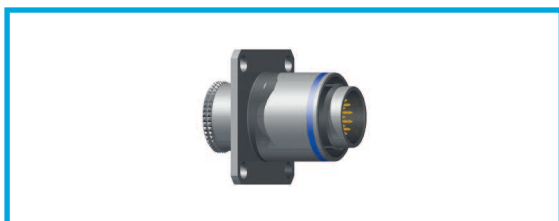

FA● Straight plug with square flange, non-coupling, key (N) or keys (P, R, S, T, U, V, W and X)

Reference		Dimensions (mm)												
Model	Series	A	B	C	D	E	G	H	K	Ls	Lr	N	P	V
FA●	MM	21.5	6.4	10.7	5.6	9.5	17.0	12.0	1.5	26.1	26.1	17.0	5.5	2.7
FA●	0M	26.9	8.8	12.7	8.0	12.2	18.9	15.1	1.5	29.1	29.1	20.6	3.9	2.7
FA●	1M	31.4	10.5	14.2	9.7	13.7	18.9	18.3	1.5	29.1	29.1	23.8	3.9	3.3
FA●	2M	34.6	14.0	17.2	13.0	16.7	18.9	20.6	1.5	29.5	29.5	26.1	3.9	3.3
FA●	3M	34.6	16.0	19.2	15.0	18.7	18.9	20.6	1.5	29.5	29.5	26.1	3.9	3.3
FA●	TM	38.0	17.9	22.0	16.7	21.5	22.5	23.0	2.0	34.8	34.8	28.5	3.4	3.3
FA●	4M	40.3	20.7	24.5	19.5	24.0	22.5	24.6	2.0	34.8	34.8	30.1	3.4	3.3
FA●	LM	43.7	23.9	28.0	22.7	27.5	22.5	27.0	2.0	34.8	34.8	32.5	3.4	3.3
FA●	5M	47.0	29.7	33.5	28.5	33.0	22.5	29.4	2.0	34.8	34.8	37.0	3.4	3.3

Part number example: FAN.1M.305.XLC

Note: The dimension «X» is the same as the FM● models.
Ls = standard gender, Lr = reverse gender.

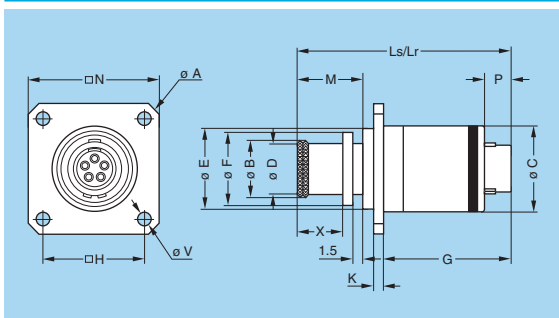
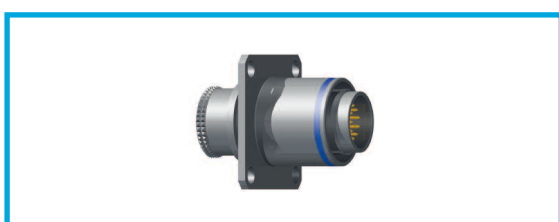

FA● Straight plug with square flange, non-coupling, key (N) or keys (P, R, S, T, U, V, W and X) with mold stop

Reference		Dimensions (mm)												
Model	Series	A	B	C	D	E	G	H	K	Ls	Lr	N	P	V
FA●	MM	21.5	6.4	10.7	5.6	9.5	17.0	12.0	1.5	29.1	29.1	17.0	5.5	2.7
FA●	0M	26.9	8.8	12.7	8.0	12.2	18.9	15.1	1.5	32.1	32.1	20.6	3.9	2.7
FA●	1M	31.4	10.5	14.2	9.7	13.7	18.9	18.3	1.5	32.1	32.1	23.8	3.9	3.3
FA●	2M	34.6	14.0	17.2	13.0	16.7	18.9	20.6	1.5	32.5	32.5	26.1	3.9	3.3
FA●	3M	34.6	16.0	19.2	15.0	18.7	18.9	20.6	1.5	32.5	32.5	26.1	3.9	3.3
FA●	TM	38.0	17.9	22.0	16.7	21.5	22.5	23.0	2.0	37.8	37.8	28.5	3.4	3.3
FA●	4M	40.3	20.7	24.5	19.5	24.0	22.5	24.6	2.0	37.8	37.8	30.1	3.4	3.3
FA●	LM	43.7	23.9	28.0	22.7	27.5	22.5	27.0	2.0	37.8	37.8	32.5	3.4	3.3
FA●	5M	47.0	29.7	33.5	28.5	33.0	22.5	29.4	2.0	37.8	37.8	37.0	3.4	3.3

Part number example: FAN.1M.305.XLCT

Note: The dimensions «F», «M» and «X» are the same as the FM● models.
Ls = standard gender, Lr = reverse gender.

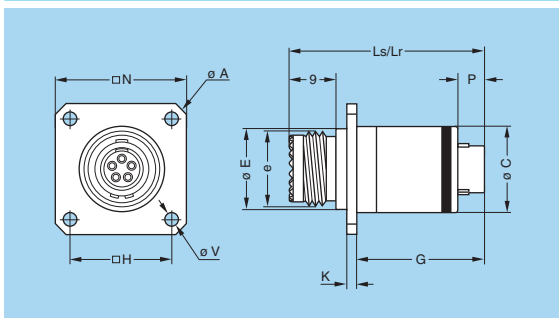

FA● Straight plug with square flange, non-coupling, key (N) or keys (P, R, S, T, U, V, W and X) with MIL-DTL-38999L shell thread

Reference		Dimensions (mm)												
Model	Series	A	C	e	E	G	H	K	Ls	Lr	N	Code ¹⁾		
FA●	1M	31.4	14.2	M12x1.0	13.7	18.9	18.3	1.5	31.4	31.4	23.8	A		
FA●	2M	34.6	17.2	M15x1.0	16.7	18.9	20.6	1.5	31.4	31.4	26.1	B		
FA●	3M	34.6	19.2	M18x1.0	18.7	18.9	20.6	1.5	31.4	31.4	26.1	C		
FA●	TM	38.0	22.0	M18x1.0	21.5	22.5	23.0	2.0	36.2	36.2	28.5	C		
FA●	4M	40.3	24.5	M22x1.0	24.0	22.5	24.6	2.0	36.2	36.2	30.1	D		
FA●	LM	43.7	28.0	M25x1.0	27.5	22.5	27.0	2.0	36.2	36.2	32.5	E		
FA●	5M	47.0	33.5	M31x1.0	33.0	22.5	29.4	2.0	36.2	36.2	37.0	F		

Part number example: FAN.1M.305.XLCM

Note: The dimensions «P» and «V» are the same as the FA● models.
Ls = standard gender, Lr = reverse gender. ¹⁾ MIL-DTL-38999L shell size code (backshell not supplied).

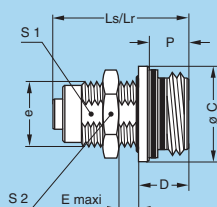

EG● Fixed socket, nut fixing, key (N) or keys (P, R, S, T, U, V, W and X)

Reference		Dimensions (mm)								
Model	Series	C	D	e	E	Ls	Lr	P	S1	S2
EG●	MM	10.7	5.2	M7x0.5	4.5	15.0	15.0	3.7	6.3	9.0
EG●	0M	12.7	6.8	M9x0.6	5.0	18.3	18.3	5.3	8.2	11.0
EG●	1M	14.2	6.8	M11x1.0	4.5	18.3	18.3	5.3	9.5	13.0
EG●	2M	17.2	6.8	M14x1.0	4.5	18.3	18.3	5.3	12.5	17.0
EG●	3M	19.2	6.8	M16x1.0	4.0	18.3	18.3	5.3	14.5	19.0
EG●	TM	22.0	9.4	M18x1.0	4.0	20.0	21.9	7.9	16.5	22.0
EG●	4M	24.5	9.4	M21x1.0	4.0	20.0	21.9	7.9	19.5	25.0
EG●	LM	28.0	9.4	M24x1.0	4.0	20.0	21.9	7.9	22.5	30.0
EG●	5M	33.5	9.4	M30x1.0	4.0	20.0	21.9	7.9	28.5	36.0

Part number example: EGN.1M.305.XLM

Panel cut-out (page 31).

Note: Ls = standard gender, Lr = reverse gender

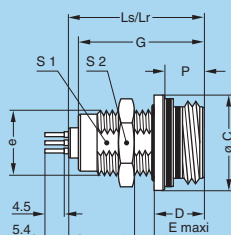

EG● Fixed socket, nut fixing, key (N) or keys (P, R, S, T, U, V, W and X) for printed circuit

Reference		Dimensions (mm)									
Model	Series	C	D	e	E	G	Ls	Lr	P	S1	S2
EG●	MM	10.7	5.2	M7x0.5	4.5	13.8	15.0	15.0	3.7	6.3	9.0
EG●	0M	12.7	6.8	M9x0.6	5.0	16.8	18.3	18.3	5.3	8.2	11.0
EG●	1M	14.2	6.8	M11x1.0	4.5	16.8	18.3	18.3	5.3	9.5	13.0
EG●	2M	17.2	6.8	M14x1.0	4.5	16.8	18.3	18.3	5.3	12.5	17.0
EG●	3M	19.2	6.8	M16x1.0	4.0	16.8	18.3	18.3	5.3	14.5	19.0
EG●	TM	22.0	9.4	M18x1.0	4.0	18.9	20.0	21.9	7.9	16.5	22.0
EG●	4M	24.5	9.4	M21x1.0	4.0	18.9	20.0	21.9	7.9	19.5	25.0
EG●	LM	28.0	9.4	M24x1.0	4.0	18.9	20.0	21.9	7.9	22.5	30.0
EG●	5M	33.5	9.4	M30x1.0	4.0	18.9	20.0	21.9	7.9	28.5	36.0

Part number example: EGN.1M.305.XLN

Panel cut-out (page 31). PCB drilling pattern (page 32).

Note: Ls = standard gender, Lr = reverse gender

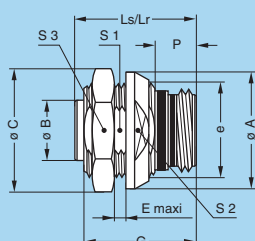

EC● Fixed socket with two nuts, key (N) or keys (P, R, S, T, U, V, W and X)

Reference		Dimensions (mm)											
Model	Series	A	B	C	E	e	G	Ls	Lr	P	S1	S2	S3
EC●	MM	14	2.85	13.5	5.0	M10x0.50	13.8	15.0	15.0	3.7	9.0	11.0	12.0
EC●	0M	17	4.72	18.2	5.0	M13x0.75	16.8	18.3	18.3	5.3	11.5	14.0	16.0
EC●	1M	18	5.95	19.2	5.0	M14x1.00	16.8	18.3	18.3	5.3	12.5	16.0	17.0
EC●	2M	21	8.95	21.5	4.0	M17x1.00	16.8	18.3	18.3	5.3	15.5	18.0	19.0
EC●	3M	23	10.95	25.0	4.0	M19x1.00	16.8	18.3	18.3	5.3	17.5	20.0	22.0
EC●	TM	27	12.30	28.0	2.5	M22x1.00	18.9	20.0	21.9	7.9	20.5	23.0	25.0
EC●	4M	29	13.95	34.0	2.5	M24x1.00	18.9	20.0	21.9	7.9	22.5	25.0	30.0
EC●	LM	33	17.95	36.0	2.5	M28x1.00	18.9	20.0	21.9	7.9	26.5	29.0	32.0
EC●	5M	38	22.90	41.0	2.5	M33x1.00	18.9	20.0	21.9	7.9	31.5	34.0	37.0

Part number example: ECN.1M.305.XLM

Panel cut-out (page 31).

Note: Ls = standard gender, Lr = reverse gender.
This model is not IP68 (no panel sealing).

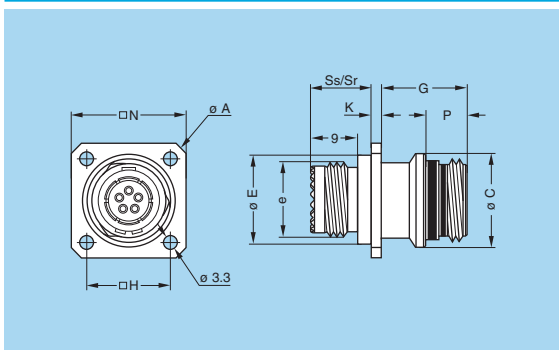
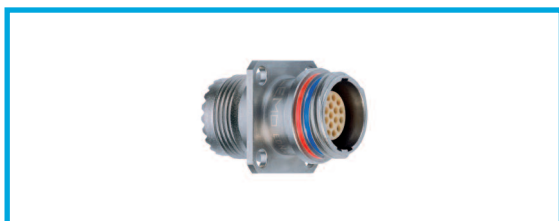

PF● Fixed socket with square flange, key (N) or keys (P, R, S, T, U, V, W and X) with MIL-DTL-38999L shell thread

Reference		Dimensions (mm)										
Model	Series	A	C	e	E	G	H	K	N	Ss	Sr	Code ¹⁾
PF●	1M	23.8	14.2	M12x1.0	12.4	12.8	12.9	1.5	18.4	12.2	12.2	A
PF●	2M	26.9	17.2	M15x1.0	15.5	12.8	15.1	1.5	20.6	12.2	12.2	B
PF●	3M	29.0	19.2	M18x1.0	17.5	12.8	16.6	1.5	22.1	12.2	12.2	C
PF●	TM	31.4	22.0	M18x1.0	19.8	14.5	18.3	2.0	23.8	11.7	13.6	C
PF●	4M	34.6	24.5	M22x1.0	22.6	14.5	20.6	2.0	26.1	11.7	13.6	D
PF●	LM	38.0	28.0	M25x1.0	25.8	14.5	23.0	2.0	28.5	11.7	13.6	E
PF●	5M	47.0	33.5	M31x1.0	33.0	14.5	29.4	2.0	37.0	11.7	13.6	G

Part number example: PFN.1M.305.XLMM

Panel cut-out (page 31).

Note: The dimension «P» is the same as the PB● models. Ss = standard gender, Sr = reverse gender. ¹⁾ MIL-DTL-38999L shell size code (backshell not supplied).

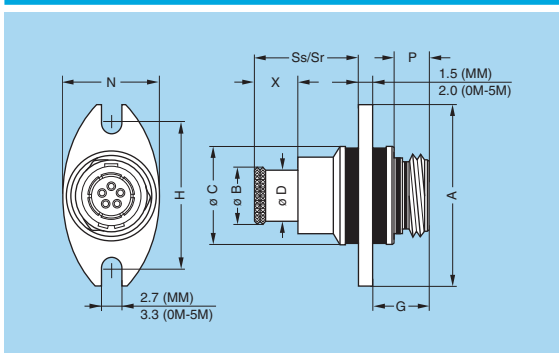
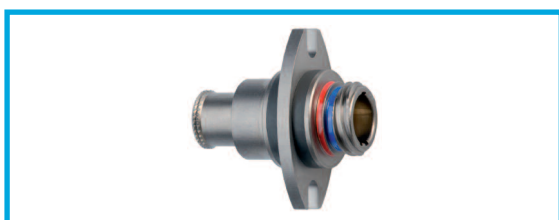

PB● Fixed socket with antivibration flange, key (N) or keys (P, R, S, T, U, V, W and X), 2 holes fixing

Reference		Dimensions (mm)										
Model	Series	A	B	C	D	G	H	N	P	Ss	Sr	X
PB●	MM	21.0	6.4	11.3	5.6	6.7	16.2	12.5	3.7	13.2	13.2	5.8
PB●	0M	27.0	8.8	14.5	8.0	8.3	21.4	16.0	5.3	15.3	15.3	6.7
PB●	1M	29.0	10.5	16.5	9.7	8.3	23.4	18.0	5.3	15.3	15.3	6.7
PB●	2M	32.0	14.0	19.5	13.0	8.3	26.4	21.0	5.3	15.7	15.7	7.1
PB●	3M	35.0	16.0	21.5	15.0	8.3	29.0	23.0	5.3	15.7	15.7	7.1
PB●	TM	38.5	17.9	24.5	16.7	11.0	32.5	26.0	7.9	15.2	17.1	7.6
PB●	4M	41.0	20.7	27.5	19.5	11.0	35.0	29.0	7.9	15.2	17.1	7.6
PB●	LM	44.0	23.9	30.5	22.7	11.0	38.0	32.0	7.9	15.2	17.1	7.6
PB●	5M	51.0	29.7	37.5	28.5	11.0	45.0	39.0	7.9	15.2	17.1	7.6

Part number example: PBN.1M.305.XLM

Panel cut-out (page 31).

Note: Ss = standard gender, Sr = reverse gender

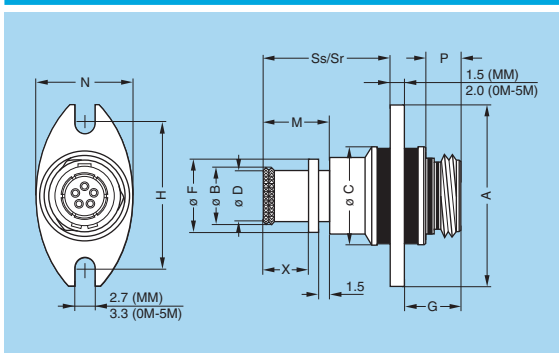

PB● Fixed socket with antivibration flange, key (N) or keys (P, R, S, T, U, V, W and X), 2 holes fixing with mold stop

Reference		Dimensions (mm)												
Model	Series	A	B	C	D	F	G	H	M	N	P	Ss	Sr	X
PB●	MM	21.0	6.4	11.3	5.6	7.8	6.7	16.2	8.8	12.5	3.7	16.2	16.2	5.8
PB●	0M	27.0	8.8	14.5	8.0	10.7	8.3	21.4	9.7	16.0	5.3	18.3	18.3	6.7
PB●	1M	29.0	10.5	16.5	9.7	12.4	8.3	23.4	9.7	18.0	5.3	18.3	18.3	6.7
PB●	2M	32.0	14.0	19.5	13.0	15.5	8.3	26.4	10.1	21.0	5.3	18.7	18.7	7.1
PB●	3M	35.0	16.0	21.5	15.0	17.5	8.3	29.0	10.1	23.0	5.3	18.7	18.7	7.1
PB●	TM	38.5	17.9	24.5	16.7	19.8	11.0	32.5	10.6	26.0	7.9	18.2	18.2	7.6
PB●	4M	41.0	20.7	27.5	19.5	22.6	11.0	35.0	10.6	29.0	7.9	18.2	18.2	7.6
PB●	LM	44.0	23.9	30.5	22.7	25.8	11.0	38.0	10.6	32.0	7.9	18.2	18.2	7.6
PB●	5M	51.0	29.7	37.5	28.5	31.4	11.0	45.0	10.6	39.0	7.9	18.2	18.2	7.6

Part number example: PBN.1M.305.XLMT

Panel cut-out (page 31).

Note: Ss = standard gender, Sr = reverse gender

DISCLAIMER The information contained within this catalog and the functions offered are intended to provide information about products. All reasonable efforts have been made to ensure the accuracy of the information. However, LEMO cannot be held responsible for any errors. LEMO does not warrant the accuracy and reserves the right to make changes to the catalog and its functions at any time without notice.

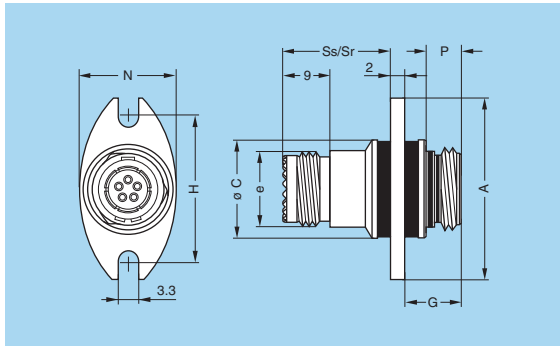
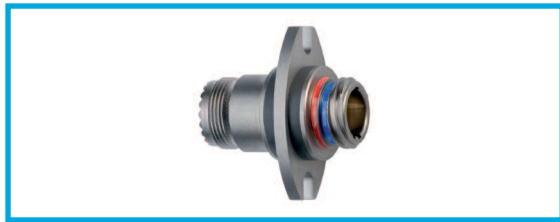

PB● Fixed socket with antivibration flange, key (N) or keys (P, R, S, T, U, V, W and X), 2 holes fixing with MIL-DTL-38999L shell thread

Reference		Dimensions (mm)									
Model	Series	A	C	e	G	H	N	P	Ss	Sr	Code ¹⁾
PB●	1M	29.0	16.5	M12x1.0	8.3	23.4	18.0	5.3	17.2	17.2	A
PB●	2M	32.0	19.5	M15x1.0	8.3	26.4	21.0	5.3	17.2	17.2	B
PB●	3M	35.0	21.5	M18x1.0	8.3	29.0	23.0	5.3	17.2	17.2	C
PB●	TM	38.5	24.5	M18x1.0	11.0	32.5	26.0	7.9	16.2	17.1	C
PB●	4M	41.0	27.5	M22x1.0	11.0	35.0	29.0	7.9	16.2	17.1	D
PB●	LM	44.0	30.5	M25x1.0	11.0	38.0	32.0	7.9	16.2	17.1	E
PB●	5M	51.0	37.5	M31x1.0	11.0	45.0	39.0	7.9	16.2	17.1	G

Part number example: PBN.1M.305.XLMM

Panel cut-out (page 31).

Note: Ss = standard gender, Sr = reverse gender. ¹⁾ MIL-DTL-38999L shell size code (backshell not supplied).

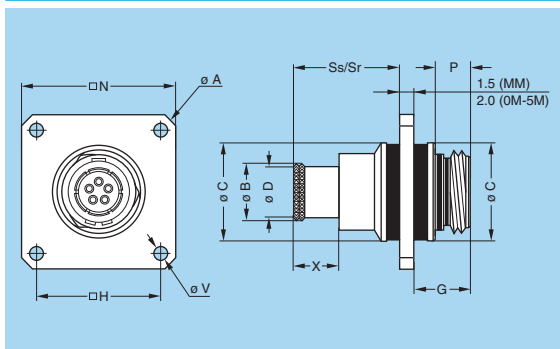
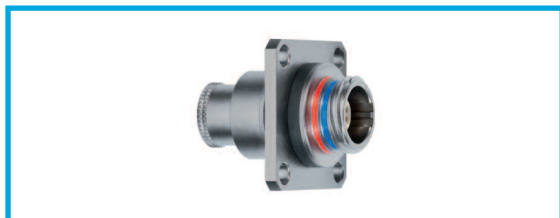

PV● Fixed socket with antivibration square flange, key (N) or keys (P, R, S, T, U, V, W and X)

Reference		Dimensions (mm)											
Model	Series	A	B	C	D	G	H	N	P	Ss	Sr	V	X
PV●	MM	21.5	6.4	11.3	5.6	6.7	12.0	17.0	3.7	13.2	13.2	2.7	5.8
PV●	0M	26.9	8.8	14.5	8.0	8.3	15.1	20.6	5.3	15.3	15.3	2.7	6.7
PV●	1M	31.4	10.5	16.5	9.7	8.3	18.3	23.8	5.3	15.3	15.3	3.3	6.7
PV●	2M	34.6	14.0	19.5	13.0	8.3	20.6	26.1	5.3	15.7	15.7	3.3	7.1
PV●	3M	38.0	16.0	21.5	15.0	8.3	23.0	28.5	5.3	15.7	15.7	3.3	7.1
PV●	TM	40.3	17.9	24.5	16.7	11.0	24.6	30.1	7.9	15.2	17.1	3.3	7.6
PV●	4M	43.7	20.7	27.5	19.5	11.0	27.0	32.5	7.9	15.2	17.1	3.3	7.6
PV●	LM	47.1	23.9	30.5	22.7	11.0	29.4	34.9	7.9	15.2	17.1	3.3	7.6
PV●	5M	54.9	29.7	37.5	28.5	11.0	34.9	40.4	7.9	15.2	17.1	3.3	7.6

Part number example: PVN.1M.305.XLM

Panel cut-out (page 31).

Note: Ss = standard gender, Sr = reverse gender

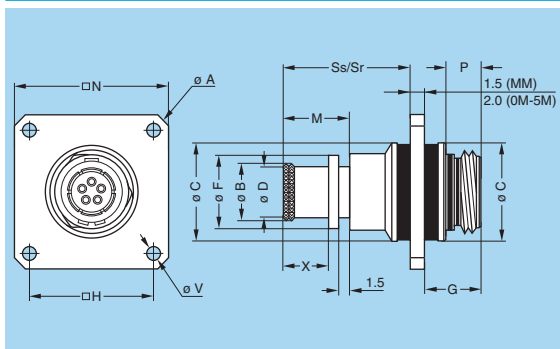
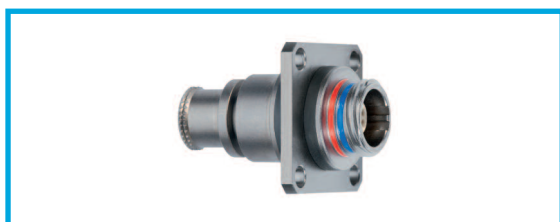

PV● Fixed socket with antivibration square flange, key (N) or keys (P, R, S, T, U, V, W and X) with mold stop

Reference		Dimensions (mm)												
Model	Series	A	B	C	D	F	G	H	M	N	P	Ss	Sr	X
PV●	MM	21.5	6.4	11.3	5.6	7.8	6.7	12.0	8.8	17.0	3.7	16.2	16.2	5.8
PV●	0M	26.9	8.8	14.5	8.0	10.7	8.3	15.1	9.7	20.6	5.3	18.3	18.3	6.7
PV●	1M	31.4	10.5	16.5	9.7	12.4	8.3	18.3	9.7	23.8	5.3	18.3	18.3	6.7
PV●	2M	34.6	14.0	19.5	13.0	15.5	8.3	20.6	10.1	26.1	5.3	18.7	18.7	7.1
PV●	3M	38.0	16.0	21.5	15.0	17.5	8.3	23.0	10.1	28.5	5.3	18.7	18.7	7.1
PV●	TM	40.3	17.9	24.5	16.7	19.8	11.0	24.6	10.6	30.1	7.9	18.2	18.2	7.6
PV●	4M	43.7	20.7	27.5	19.5	22.6	11.0	27.0	10.6	32.5	7.9	18.2	18.2	7.6
PV●	LM	47.1	23.9	30.5	22.7	25.8	11.0	29.4	10.6	34.9	7.9	18.2	18.2	7.6
PV●	5M	54.9	29.7	37.5	28.5	31.4	11.0	34.9	10.6	40.4	7.9	18.2	18.2	7.6

Part number example: PVN.1M.305.XLMT

Panel cut-out (page 31).

Note: Ss = standard gender, Sr = reverse gender. The dimension «V» is the same as the PV● models without mold stop.

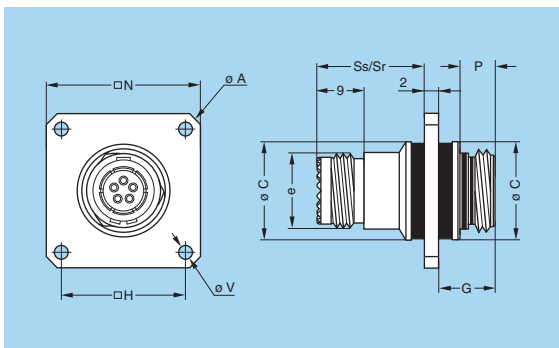
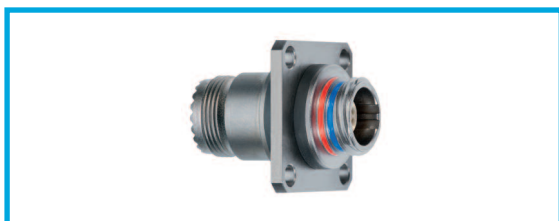

PV● Fixed socket with antivibration square flange, key (N) or keys (P, R, S, T, U, V, W and X) with MIL-DTL-38999L shell thread

Reference		Dimensions (mm)										
Model	Series	A	C	e	G	H	N	P	Ss	Sr	V	Code ¹⁾
PV●	1M	31.4	16.5	M12x1.0	8.3	18.3	23.8	5.3	17.2	17.2	3.3	A
PV●	2M	34.6	19.5	M15x1.0	8.3	20.6	26.1	5.3	17.2	17.2	3.3	B
PV●	3M	38.0	21.5	M18x1.0	8.3	23.0	28.5	5.3	17.2	17.2	3.3	C
PV●	TM	40.3	24.5	M18x1.0	11.0	24.6	30.1	7.9	16.2	17.1	3.3	C
PV●	4M	43.7	27.5	M22x1.0	11.0	27.0	32.5	7.9	16.2	17.1	3.3	D
PV●	LM	47.1	30.5	M25x1.0	11.0	29.4	34.9	7.9	16.2	17.1	3.3	E
PV●	5M	54.9	37.5	M31x1.0	11.0	34.9	40.4	7.9	16.2	17.1	3.3	G

Part number example: PVN.1M.305.XLMM

Panel cut-out (page 31).

Note: Ss = standard gender, Sr = reverse gender. ¹⁾ MIL-DTL-38999L shell size code (backshell not supplied).

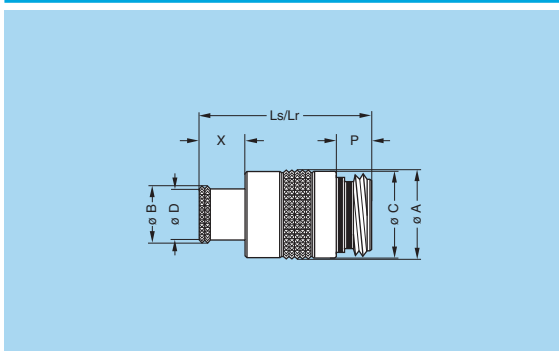

PM● Free socket, key (N) or keys (P, R, S, T, U, V, W and X) with knurled grip

Reference		Dimensions (mm)							
Model	Series	A	B	C	D	Ls	Lr	P	X
PM●	MM	11.1	6.4	10.7	5.6	21.4	21.4	3.7	5.8
PM●	0M	13.1	8.8	12.7	8.0	25.6	25.6	5.3	6.7
PM●	1M	14.6	10.5	14.2	9.7	25.6	25.6	5.3	6.7
PM●	2M	17.6	14.0	17.2	13.0	26.0	26.0	5.3	7.1
PM●	3M	19.6	16.0	19.2	15.0	26.0	26.0	5.3	7.1
PM●	TM	22.5	17.9	22.0	16.7	28.2	30.1	7.9	7.6
PM●	4M	25.0	20.7	24.5	19.5	28.2	30.1	7.9	7.6
PM●	LM	28.5	23.9	28.0	22.7	28.2	30.1	7.9	7.6
PM●	5M	34.0	29.7	33.5	28.5	28.2	30.1	7.9	7.6

Part number example: PMN.1M.305.XLM

Note: Ls = standard gender, Lr = reverse gender

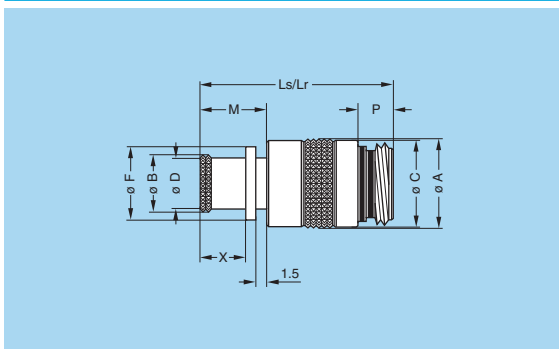

PM● Free socket, key (N) or keys (P, R, S, T, U, V, W and X) with knurled grip and mold stop

Reference		Dimensions (mm)									
Model	Series	A	B	C	D	F	Ls	Lr	M	P	X
PM●	MM	11.1	6.4	10.7	5.6	7.8	24.4	24.4	8.8	3.7	5.8
PM●	0M	13.1	8.8	12.7	8.0	10.7	28.6	28.6	9.7	5.3	6.7
PM●	1M	14.6	10.5	14.2	9.7	12.4	28.6	28.6	9.7	5.3	6.7
PM●	2M	17.6	14.0	17.2	13.0	15.5	29.0	29.0	10.1	5.3	7.1
PM●	3M	19.6	16.0	19.2	15.0	17.5	29.0	29.0	10.1	5.3	7.1
PM●	TM	22.5	17.9	22.0	16.7	19.8	31.2	31.2	10.6	7.9	7.6
PM●	4M	25.0	20.7	24.5	19.5	22.6	31.2	31.2	10.6	7.9	7.6
PM●	LM	28.5	23.9	28.0	22.7	25.8	31.2	31.2	10.6	7.9	7.6
PM●	5M	34.0	29.7	33.5	28.5	31.4	31.2	31.2	10.6	7.9	7.6

Part number example: PMN.1M.305.XLMT

Note: Ls = standard gender, Lr = reverse gender

DISCLAIMER The information contained within this catalog and the functions offered are intended to provide information about products. All reasonable efforts have been made to ensure the accuracy of the information. However, LEMO cannot be held responsible for any errors. LEMO does not warrant the accuracy and reserves the right to make changes to the catalog and its functions at any time without notice.

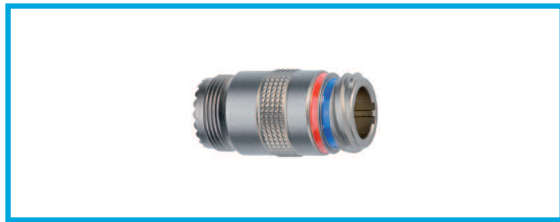

PM● Free socket, key (N) or keys (P, R, S, T, U, V, W and X) with knurled grip and MIL-DTL-38999L shell thread

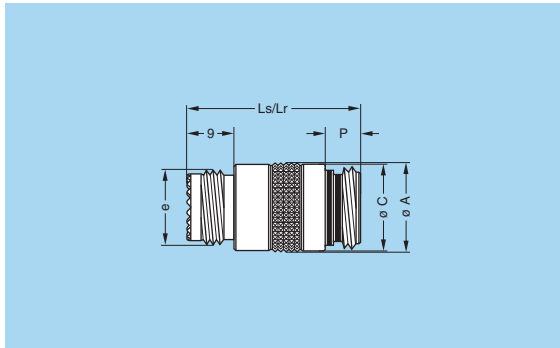

Reference		Dimensions (mm)						
Model	Series	A	C	e	Ls	Lr	P	Code ¹⁾
PM●	1M	14.6	14.2	M12x1.0	27.9	27.9	5.3	A
PM●	2M	17.6	17.2	M15x1.0	27.9	27.9	5.3	B
PM●	3M	19.6	19.2	M18x1.0	27.9	27.9	5.3	C
PM●	TM	22.5	22.0	M18x1.0	29.6	30.1	7.9	C
PM●	4M	25.0	24.5	M22x1.0	29.6	30.1	7.9	D
PM●	LM	28.5	28.0	M25x1.0	29.6	30.1	7.9	E
PM●	5M	34.0	33.5	M31x1.0	29.6	30.1	7.9	G

Part number example: PMN.1M.305.XLMM

Note: Ls = standard gender, Lr = reverse gender. ¹⁾ MIL-DTL-38999L shell size code (backshell not supplied).



PH● Free socket, key (N) or keys (P, R, S, T, U, V, W and X) with arctic grip

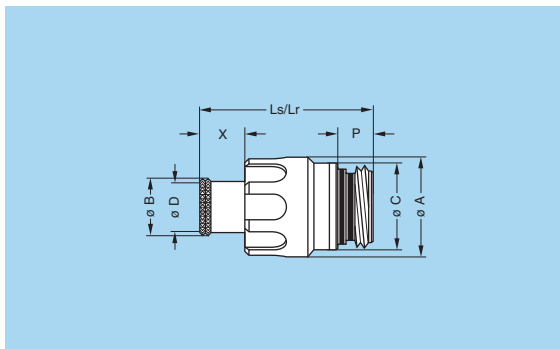

Reference		Dimensions (mm)							
Model	Series	A	B	C	D	Ls	Lr	P	X
PH●	MM	12.0	6.4	10.7	5.6	21.4	21.4	3.7	5.8
PH●	0M	14.4	8.8	12.7	8.0	25.6	25.6	5.3	6.7
PH●	1M	15.9	10.5	14.2	9.7	25.6	25.6	5.3	6.7
PH●	2M	18.9	14.0	17.2	13.0	26.0	26.0	5.3	7.1
PH●	3M	20.9	16.0	19.2	15.0	26.0	26.0	5.3	7.1
PH●	TM	23.4	17.9	22.0	16.7	28.2	30.1	7.9	7.6
PH●	4M	25.9	20.7	24.5	19.5	28.2	30.1	7.9	7.6
PH●	LM	29.4	23.9	28.0	22.7	28.2	30.1	7.9	7.6
PH●	5M	34.9	29.7	33.5	28.5	28.2	30.1	7.9	7.6

Part number example: PHN.1M.305.XLM

Note: Ls = standard gender, Lr = reverse gender



PH● Free socket, key (N) or keys (P, R, S, T, U, V, W and X) with arctic grip and mold stop

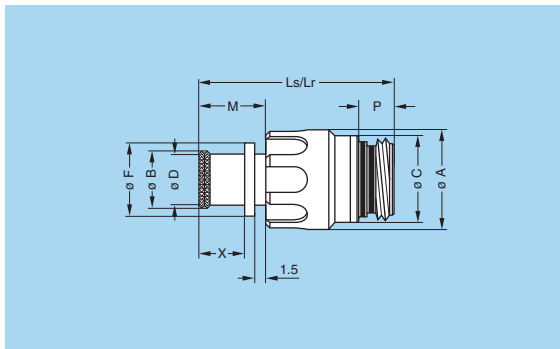

Reference		Dimensions (mm)									
Model	Series	A	B	C	D	F	Ls	Lr	M	P	X
PH●	MM	12.0	6.4	10.7	5.6	7.8	24.4	24.4	8.8	3.7	5.8
PH●	0M	14.4	8.8	12.7	8.0	10.7	28.6	28.6	9.7	5.3	6.7
PH●	1M	15.9	10.5	14.2	9.7	12.4	28.6	28.6	9.7	5.3	6.7
PH●	2M	18.9	14.0	17.2	13.0	15.5	29.0	29.0	10.1	5.3	7.1
PH●	3M	20.9	16.0	19.2	15.0	17.5	29.0	29.0	10.1	5.3	7.1
PH●	TM	23.4	17.9	22.0	16.7	19.8	31.2	31.2	10.6	7.9	7.6
PH●	4M	25.9	20.7	24.5	19.5	22.6	31.2	31.2	10.6	7.9	7.6
PH●	LM	29.4	23.9	28.0	22.7	25.8	31.2	31.2	10.6	7.9	7.6
PH●	5M	34.9	29.7	33.5	28.5	31.4	31.2	31.2	10.6	7.9	7.6

Part number example: PHN.1M.305.XLMT

Note: Ls = standard gender, Lr = reverse gender



PH● Free socket, key (N) or keys (P, R, S, T, U, V, W and X) with arctic grip and MIL-DTL-38999L shell thread

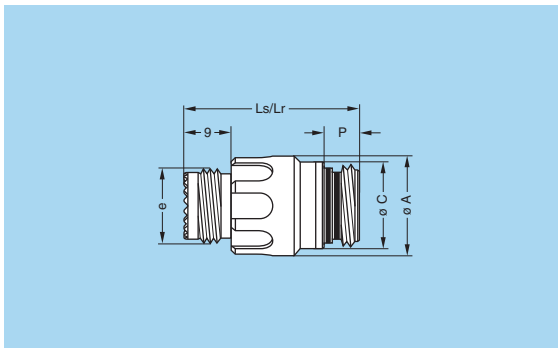

Reference		Dimensions (mm)						
Model	Series	A	C	e	Ls	Lr	P	Code ¹⁾
PH●	1M	15.9	14.2	M12x1.0	27.9	27.9	5.3	A
PH●	2M	18.9	17.2	M15x1.0	27.9	27.9	5.3	B
PH●	3M	20.9	19.2	M18x1.0	27.9	27.9	5.3	C
PH●	TM	23.4	22.0	M18x1.0	29.6	30.1	7.9	C
PH●	4M	25.9	24.5	M22x1.0	29.6	30.1	7.9	D
PH●	LM	29.4	28.0	M25x1.0	29.6	30.1	7.9	E
PH●	5M	34.9	33.5	M31x1.0	29.6	30.1	7.9	G

Part number example: PHN.1M.305.XLMM

Note: Ls = standard gender, Lr = reverse gender. ¹⁾ MIL-DTL-38999L shell size code (backshell not supplied).

Watertight model (unmated)



HE● Fixed socket, nut fixing, key (N) or keys (P, R, S, T, U, V, W and X) for printed circuit, watertight (back panel mounting)

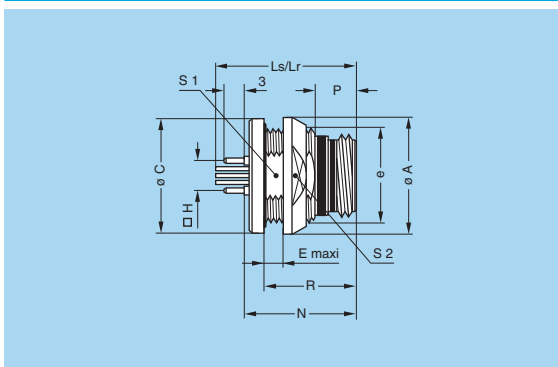

Reference		Dimensions (mm)											
Model	Series	A	C	e	E	H	Ls	Lr	N	P	R	S1	S2
HE●	MM	14	13.8	M10x0.50	4.0	5.08	20.4	20.4	15.3	3.7	10.5	9.0	11
HE●	0M	17	16.8	M13x0.75	5.0	5.08	20.8	21.0	16.8	5.3	13.8	11.5	14
HE●	1M	18	17.8	M14x1.00	5.0	7.62	20.8	21.0	16.8	5.3	13.8	12.5	16
HE●	2M	21	20.8	M17x1.00	5.0	8.89	20.8	21.0	16.8	5.3	13.8	15.5	18
HE●	3M	23	22.8	M19x1.00	5.0	10.16	20.8	21.0	16.8	5.3	13.8	17.5	20
HE●	TM	27	25.8	M22x1.00	4.0	12.70	24.6	24.6	19.9	7.9	16.9	20.5	23
HE●	4M	29	27.8	M24x1.00	4.0	13.97	24.6	24.6	19.9	7.9	16.9	22.5	25
HE●	LM	33	31.8	M28x1.00	4.0	16.51	24.6	24.6	19.9	7.9	16.9	26.5	29
HE●	5M	38	36.8	M33x1.00	4.0	20.32	24.6	24.6	19.9	7.9	16.9	31.5	34

Part number example: HEN.1M.305.XLNP

Panel cut-out (page 31). PCB drilling pattern (page 32).

Note: Ls = standard gender, Lr = reverse gender.
Operating temperature: -20°C to +80°C.

Fibre optic models

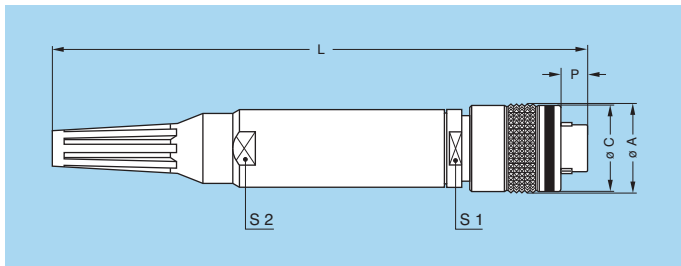
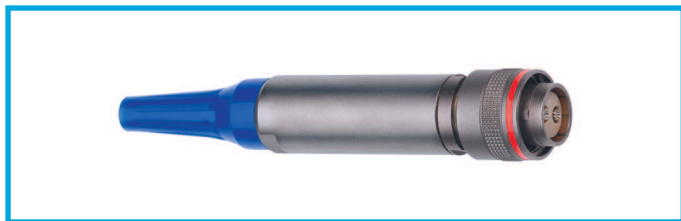

FM Straight plug, keys (N, S or W) with knurled grip

Part number	Dimensions (mm)					
	A	C	L	P	S1	S2
FM•2M.03A.XLZT••Z	17.6	17.2	100.6	3.9	14	14
FM•3M.95B.XLCT••Z	19.6	19.2	103.3	3.9	16	16
FM•5M.03W.XLZT••Z	34.0	33.5	148.4	3.4	29	29

Contact part number (to be ordered separately):
PSS.F7.12•LCE23 (2M series).
FFS.F7.12•LCE23 (3M and 5M series).

Note: •• Cable adaptor defined upon request.
The bend relief must be ordered separately (see page 29).

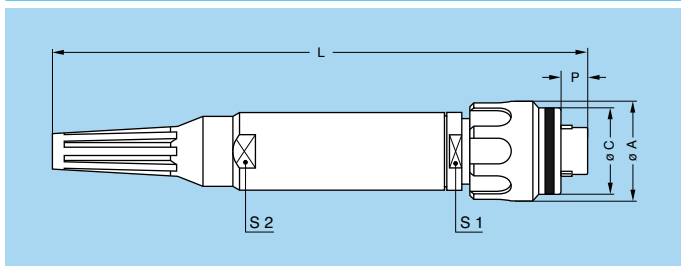
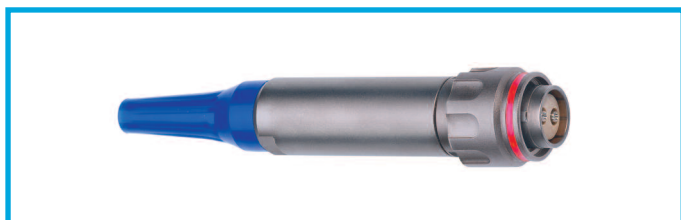

FG Straight plug, keys (N, S or W) with arctic grip

Part number	Dimensions (mm)					
	A	C	L	P	S1	S2
FG•2M.03A.XLZT••Z	18.9	17.2	100.6	3.9	14	14
FG•3M.95B.XLCT••Z	20.9	19.2	103.3	3.9	16	16
FG•5M.03W.XLZT••Z	34.9	33.5	148.4	3.4	29	29

Contact part number (to be ordered separately):
PSS.F7.12•LCE23 (2M series).
FFS.F7.12•LCE23 (3M and 5M series).

Note: •• Cable adaptor defined upon request.
The bend relief must be ordered separately (see page 29).

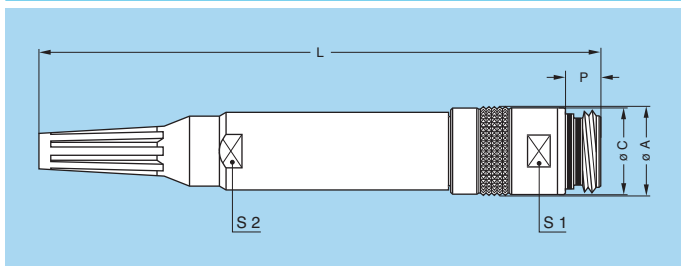

PM Free socket, keys (N, S or W) with knurled grip

Part number	Dimensions (mm)					
	A	C	L	P	S1	S2
PM•2M.03A.XLZT••Z	17.6	17.2	105.8	5.3	16	14
PM•3M.95B.XLMT••Z	19.6	19.2	113.3	5.3	18	16
PM•5M.03W.XLZT••Z	34.0	33.5	155.2	7.9	32	29

Contact part number (to be ordered separately):
FFS.F7.12•LCL23 (2M series).
PSS.F7.12•LCL23 (3M and 5M series).

Note: •• Cable adaptor defined upon request.
The bend relief must be ordered separately (see page 29).

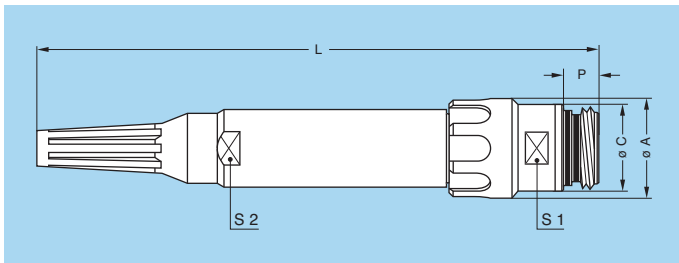
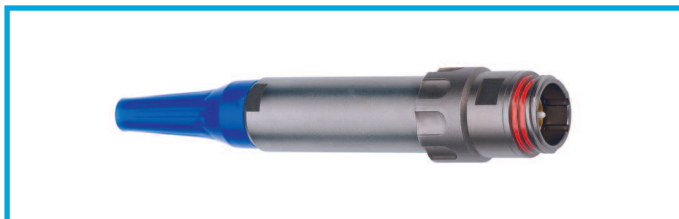

PH● Free socket, keys (S or W) with arctic grip

Part number	Dimensions (mm)					
	A	C	L	P	S1	S2
PH●.2M.03A.XLZT●Z	18.9	17.2	105.8	5.3	16	14
PH●.5M.03W.XLZT●Z	34.9	33.5	155.2	7.9	32	29

Contact part number (to be ordered separately):
FFS.F7.12●.LCL23 (2M series).
PSS.F7.12●.LCL23 (5M series).

Note: ●● Cable adaptor defined upon request.
The bend relief must be ordered separately (see page 29).

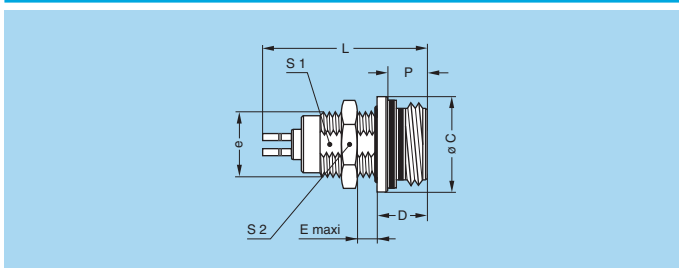
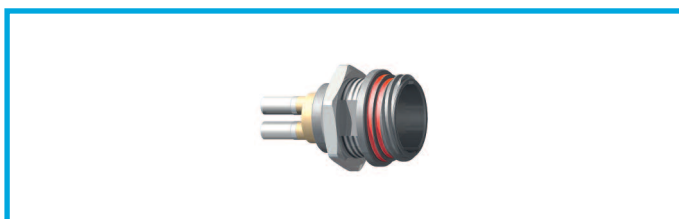

EG● Fixed socket, nut fixing, key (N) or keys (P, R, S, T, U, V, W and X)

Part number	Dimensions (mm)							
	C	D	e	E	L	P	S1	S2
EG●.2M.03A.XLZ	17.2	6.8	M14x1.0	4.5	28.9	5.3	12.5	17.0
EG●.5M.03W.XLZ	33.5	9.4	M30x1.0	4.0	30.8	7.9	28.5	36.0

Panel cut-out (page 31).

Contact part number (to be ordered separately):
FFS.F7.12●.LCE23 (2M series).
PSS.F7.12●.LCE23 (5M series).

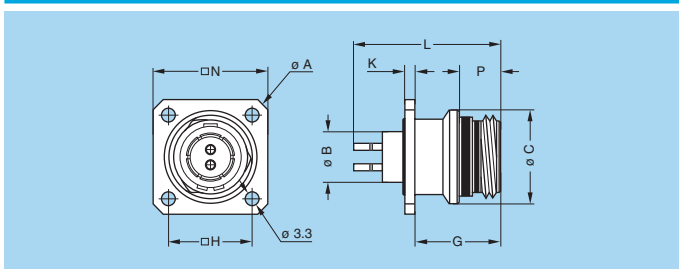
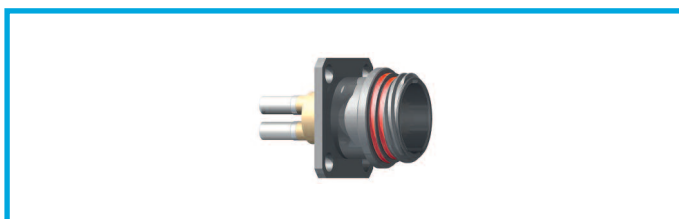

ED● Fixed socket with square flange, keys (N, S or W)

Part number	Dimensions (mm)								
	A	B	C	G	H	K	L	N	P
ED●.2M.03A.XLZT	26.9	8.95	17.2	12.8	15.1	1.5	28.9	20.6	5.3
ED●.3M.95B.XLM	29.0	10.95	19.2	12.8	16.6	1.5	32.2	22.1	5.3
ED●.5M.03W.XLZT	43.7	22.90	33.5	14.5	27.0	2.0	30.8	32.5	7.9

Panel cut-out (page 31).

Contact part number (to be ordered separately):
FFS.F7.12●.LCE23 (2M series).
PSS.F7.12●.LCE23 (3M and 5M series).

More information on F7 fibre optic contact in LEMO F7 catalog.

DISCLAIMER The information contained within this catalog and the functions offered are intended to provide information about products. All reasonable efforts have been made to ensure the accuracy of the information. However, LEMO cannot be held responsible for any errors. LEMO does not warrant the accuracy and reserves the right to make changes to the catalog and its functions at any time without notice.

Fibre Type

The choice of the ferrule hole diameter is dependent upon the fibre cladding size. LEMO offers a range of ferrule hole diameters to suit the users' specific requirements.

● First choice alternative ○ Special order alternative

Reference	∅ Core/Cladding (µm)	Ferrule hole diameter (µm)	Note
125	9/125	125	●
126	50/125	126	●
128	62.5/125	128	○

Accessories

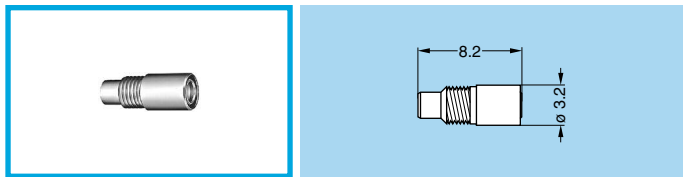

PSS Alignment device for F7 fibre optic contact

Part number
PSS.F7.290.NZZ

Note: Alignment device should be ordered as replacement item.

Tooling



DCP Set of flat spanners for collet nuts

Part number
DCP.2M.110.TN
DCP.3M.110.TN
DCP.5M.110.TN



DCS F7 contact alignment device tool

Simple tool with two threaded end for installation/extraction of the F7 contact alignment device.

Part number
DCS.F7.035.PN



WST Cleaning kit

Fibre optic cleaning kit of 2 cotton buds, 1 dry and 1 being soaked in Isopropyl Alcohol used for cleaning the fibre optic contacts.

Part number
WST.KI.125.34

See also F7 tooling in the F7 fibre optic catalog.

USB models

FM●LM.U2A.XPAT Straight plug, key (W) or key (R) with knurled grip and mold stop

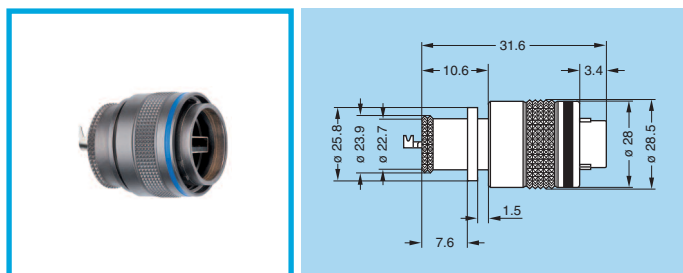

FG●LM.U2A.XPAT Straight plug, key (W) or key (R) with arctic grip and mold stop

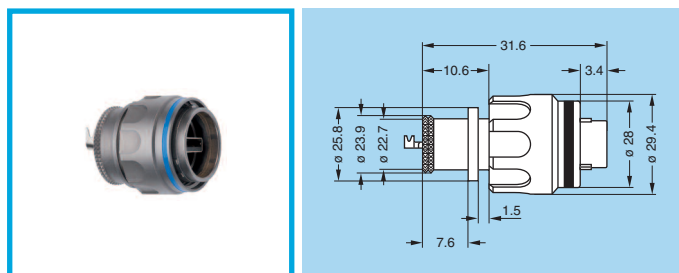

EG●LM.U2A.XPP Fixed socket, female to female, nut fixing, key (W) or key (R)

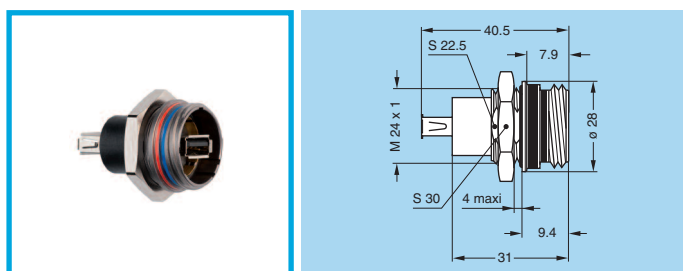

EG●LM.U2A.XPL Fixed socket, nut fixing, key (W) or key (R)

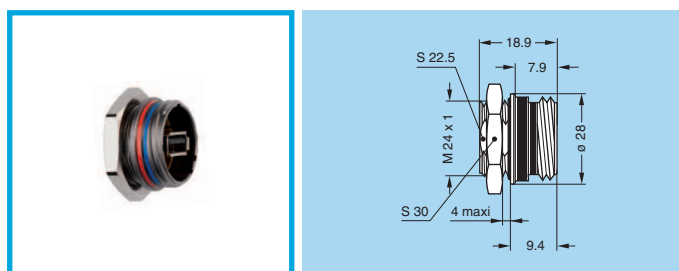

Alignment Key

Alignment Key and Polarized Keying System

M series connector model part numbers are composed of three letters. The LAST LETTER indicates the keys corresponding to a particular contact type.

For example, straight plugs with N, P, R, U or W keys, are fitted with male contacts; whereas with S, T, V or X keys, plugs are fitted with female contacts. Sockets with N, P, R, U or W keys, are fitted with female contacts; whereas with S, T, V or X keys, sockets are fitted with male contacts.











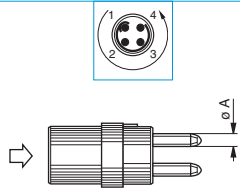
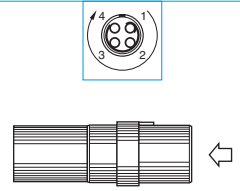





























































MM to 3M	Front view of a socket 	Model	Colour code	Contact type		Nb of keys	Angles	
				Plug	Socket		β	γ
				●●N	blue		male	female
●●P	yellow	male	female	3	150°	60°		
●●U	green	male	female	3	130°	100°		
●●S	red	female	male	3	155°	50°		
●●T	orange	female	male	3	135°	90°		

TM to 5M	Front view of a socket 	Model	Colour code	Contact type		Nb of keys	Angles			
				Plug	Socket		α	β	γ	δ
				●●W	blue		male	female	5	95°
●●R	yellow	male	female	5	105°	115°	30°	20°		
●●X	red	female	male	5	100°	125°	40°	20°		
●●V	orange	female	male	5	110°	120°	35°	25°		

DISCLAIMER The information contained within this catalog and the functions offered are intended to provide information about products. All reasonable efforts have been made to ensure the accuracy of the information. However, LEMO cannot be held responsible for any errors. LEMO does not warrant the accuracy and reserves the right to make changes to the catalog and its functions at any time without notice.

Insert configuration

Multipole

	 Male crimp contacts for plug		 Female crimp contacts for sockets		Reference	Number of contacts	ø A (mm)	Contact type		AWG	Test voltage (kV rms) ¹⁾ Contact-contact	Test voltage (kV rms) ¹⁾ Contact-shell	Rated current (A) ¹⁾
	Crimp	Print (straight) ²⁾											
MM					303	3	0.5	●	●	28-30-32	1.15	0.95	3.0
					304	4	0.5	●	●	28-30-32	0.95	0.90	2.0
OM					302	2	0.9	●	●	20-22-24	1.45	1.00	10.0
					303	3	0.9	●	●	20-22-24	1.70	1.40	8.0
					304	4	0.7	●	●	22-24-26	1.35	0.90	7.0
					305	5	0.7	●	●	22-24-26	1.25	1.00	6.5
1M					302	2	1.3	●	●	16-18-20	1.55	1.10	19.0
					303	3	1.3	●	●	16-18-20	1.05	0.95	15.5
					305	5	0.9	●	●	20-22-24	1.30	1.30	9.0
					307	7	0.7	●	●	22-24-26	1.45	1.20	7.0
					308	8	0.7	●	●	22-24-26	1.30	1.10	5.0
2M					304	4	1.3	●	●	16-18-20	1.55	1.35	15.5
					308	8	0.9	●	●	20-22-24	1.95	1.10	10.0
					310	10	0.9	●	●	20-22-24	1.80	1.20	8.0
					312	12	0.7	●	●	22-24-26	1.65	1.15	7.0
					319	19	0.7	●	●	22-24-26	1.20	1.00	4.0
3M					322	22	0.7	●	●	22-24-26	1.25	1.15	4.0
					330	30	0.7	●	●	22-24-26	1.10	1.00	3.5

Note: ¹⁾ Test voltage according to IEC 60512-2 test 4a. ²⁾ For EG•, EC•, ED•, HE• socket.

DISCLAIMER The information contained within this catalog and the functions offered are intended to provide information about products. All reasonable efforts have been made to ensure the accuracy of the information. However, LEMO cannot be held responsible for any errors. LEMO does not warrant the accuracy and reserves the right to make changes to the catalog and its functions at any time without notice.



Multipole

	 Male crimp contacts for plug	 Female crimp contacts for sockets	Reference	Number of contacts	ø A (mm)	Contact type		AWG	Test voltage (kV rms) ¹⁾ Contact-contact	Test voltage (kV rms) ¹⁾ Contact-shell	Rated current (A) ¹⁾
						Crimp	Print (straight) ²⁾				
TM			325	25	0.9	●	●	20-22-24	1.10	1.25	5.0
			340	40	0.7	●	●	22-24-26	1.05	1.20	3.0
4M			340	40	0.7	●	●	22-24-26	1.20	1.35	3.5
			348	48	0.7	●	●	22-24-26	1.10	1.35	3.0
LM			355	55	0.9	●	●	20-22-24	1.65	1.95	3.5
			368	68	0.7	●	●	22-24-26	1.40	1.65	2.5
5M			366	66	0.9	●	●	20-22-24	1.60	1.70	3.0
			114	114	0.7	●	●	22-24-26	1.37	1.34	2.0

Note: ¹⁾ Test voltage according to IEC 60512-2 test 4a. ²⁾ For EG•, EC•, ED•, HE• socket.

DISCLAIMER The information contained within this catalog and the functions offered are intended to provide information about products. All reasonable efforts have been made to ensure the accuracy of the information. However, LEMO cannot be held responsible for any errors. LEMO does not warrant the accuracy and reserves the right to make changes to the catalog and its functions at any time without notice.

Mixed multipole

	Male crimp contacts for plug	Female crimp contacts for sockets	Reference	Number of contacts	ø A (mm)	Contact type		AWG	Test voltage (kV rms) ¹⁾ Contact-contact	Test voltage (kV rms) ¹⁾ Contact-shell	Rated current (A) ¹⁾
						Crimp	Print (straight) ²⁾				
1M			304	2 2	0.7 1.3	●	●	22-24-26 16-18-20	1.20 1.45	1.30 2.00	11.0 18.5
2M			306	3 3	0.7 1.3	●	●	22-24-26 16-18-20	1.55 2.05	1.40 1.35	10.5 18.0
			308	6 2	0.7 1.3	●	●	22-24-26 16-18-20	1.95 1.75	1.40 1.60	7.0 23.0
			310	8 2	0.7 1.3	●	●	22-24-26 16-18-20	1.35 1.90	1.35 1.15	6.0 23.0

FGN.1M.304.XRCT2: straight plug with key (N), 1M series, multipole type with 4 mixed contacts (2 x ø 0.7 mm and 2 x ø 1.3 mm), outer shell with mold stop in anthracite nickel-plated aluminium alloy, PEEK insulator, male crimp contacts.

FGN.2M.308.XRC6: straight plug with key (N), 2M series, multipole type with 8 mixed contacts (6 x ø 0.7 mm and 2 x ø 1.3 mm), outer shell in anthracite nickel-plated aluminium alloy, PEEK insulator, male crimp contacts.

Note: ¹⁾ Test voltage according to IEC 60512-2 test 4a. ²⁾ For EG•, EC•, ED•, HE• socket.

Multi fibre and Mixed fibre optic + LV

	Male contacts for plug	Female contacts for sockets	Reference	Fibre optic No	Contact No	ø A (mm)	Low Voltage contact			Rated current (A)
							Contact type	Crimp contact		
							Crimp	Test voltage (kV rms) ¹⁾ Contact-contact	Test voltage (kV rms) ¹⁾ Contact-shell	
2M			03A	2	-	-	-	-	-	-
3M			95B	4	4	0.9	●	1.00	0.80	8.0
5M			03W	21	-	-	-	-	-	-

Note: ¹⁾ Test voltage according to IEC 60512-2 test 4a.

DISCLAIMER The information contained within this catalog and the functions offered are intended to provide information about products. All reasonable efforts have been made to ensure the accuracy of the information. However, LEMO cannot be held responsible for any errors. LEMO does not warrant the accuracy and reserves the right to make changes to the catalog and its functions at any time without notice.



USB

	Male front view	Female front view	Reference	Number of contacts	Solder contact	Test voltage (kV rms) ¹⁾ Contact-contact	Test voltage (kV rms) ¹⁾ Contact-shell	Rated current (A) ¹⁾
LM			U2A	4	●	1.20	0.95	n.a.

Contacts

Reference	Contact type
C	Male crimp with standard crimp barrel (fig. 1)
B	Male crimp with reduced crimp barrel (fig. 2)
D	Male straight print

Reference	Contact type
M	Female crimp with standard crimp barrel (fig. 1)
P	Female crimp with reduced crimp barrel (fig. 2)
N	Female straight print

Crimp contacts for plugs, free or fixed sockets

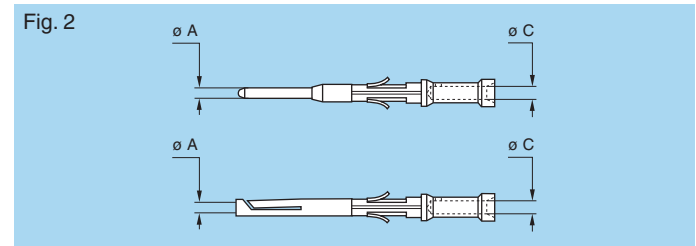
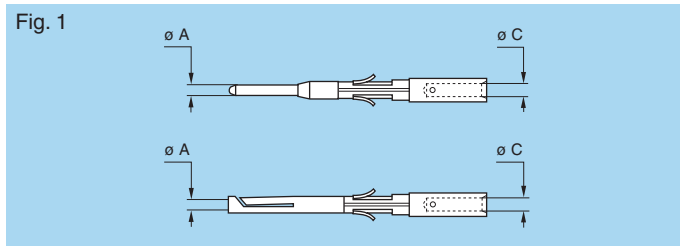

Dimension of crimp barrels

	Contact			Ref. contact type		Conductor				Part number	
	ø A (mm)	ø C (mm)	Form per fig.	Male	Female	AWG		Section (mm ²)		For male contacts	For female contacts
						min.	max.	min.	max.		
MM	0.5	0.42	1	C	M	32	28	0.035	0.090	FGG.00.554.ZZC	EGG.00.654.ZZM
0M to 3M	1.3	1.60	1	C	M	20	16	0.616	2.000	FGN.0M.565.ZZC	EGN.0M.665.ZZM
	0.9	1.10	1	C	M	24	20	0.204	0.616	FGN.0M.560.ZZC	EGN.0M.660.ZZM
	0.9	0.87	2	B	P	26	22	0.128	0.382	FGN.0M.561.ZZC	EGN.0M.661.ZZM
	0.7	0.87	1	C	M	26	22	0.128	0.382	FGN.0M.555.ZZC	EGN.0M.655.ZZM
	0.7	0.44	2	B	P	32	28	0.032	0.092	FGN.0M.556.ZZC	EGN.0M.656.ZZM
TM to 5M	1.3	1.60	1	C	M	20	16	0.616	2.000	FGN.0M.565.ZZC	EGN.0M.665.ZZM
	0.9	1.10	1	C	M	24	20	0.204	0.616	FGN.0M.560.ZZC	EGW.TM.660.ZZM
	0.9	0.87	2	B	P	26	22	0.128	0.382	FGN.0M.561.ZZC	EGW.TM.661.ZZM
	0.7	0.87	1	C	M	26	22	0.128	0.382	FGN.0M.555.ZZC	EGW.TM.655.ZZM
	0.7	0.44	2	B	P	32	28	0.032	0.092	FGN.0M.556.ZZC	EGW.TM.656.ZZM

Note: In order to satisfy crimp pull-test requirements to the IEC 60352-2 standard, the use of single strand cables should be avoided.

DISCLAIMER The information contained within this catalog and the functions offered are intended to provide information about products. All reasonable efforts have been made to ensure the accuracy of the information. However, LEMO cannot be held responsible for any errors. LEMO does not warrant the accuracy and reserves the right to make changes to the catalog and its functions at any time without notice.

Accessories

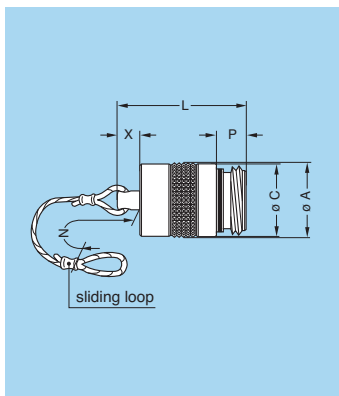

BMF Blanking caps for plugs

Part number	Dimensions (mm)					
	A	C	L	N	P	X
BMF.MM.100.●AV	11.1	10.7	17.8	60.0	3.7	4.0
BMF.0M.100.●AV	13.1	12.7	24.6	85.0	5.3	6.0
BMF.1M.100.●AV	14.6	14.2	24.6	85.0	5.3	6.0
BMF.2M.100.●AV	17.6	17.2	24.6	85.0	5.3	6.0
BMF.3M.100.●AV	19.6	19.2	24.6	120.0	5.3	6.0
BMF.TM.100.●AV	22.5	22.0	31.1	120.0	7.9	10.0
BMF.4M.100.●AV	25.0	24.5	31.1	120.0	7.9	10.0
BMF.LM.100.●AV	28.5	28.0	31.1	150.0	7.9	10.0
BMF.5M.100.●AV	34.0	33.5	31.1	150.0	7.9	10.0

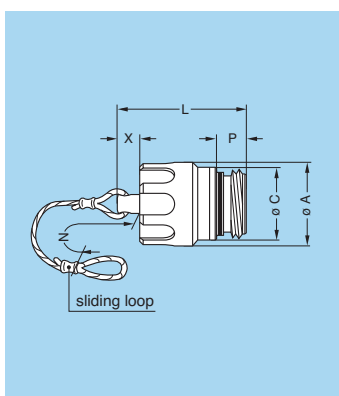

BGF Blanking caps for plugs

Part number	Dimensions (mm)					
	A	C	L	N	P	X
BGF.MM.100.●AV	12.0	10.7	17.8	60.0	3.7	4.0
BGF.0M.100.●AV	14.4	12.7	24.6	85.0	5.3	6.0
BGF.1M.100.●AV	15.9	14.2	24.6	85.0	5.3	6.0
BGF.2M.100.●AV	18.9	17.2	24.6	85.0	5.3	6.0
BGF.3M.100.●AV	20.9	19.2	24.6	120.0	5.3	6.0
BGF.TM.100.●AV	23.4	22.0	31.1	120.0	7.9	10.0
BGF.4M.100.●AV	25.9	24.5	31.1	120.0	7.9	10.0
BGF.LM.100.●AV	29.4	28.0	31.1	150.0	7.9	10.0
BGF.5M.100.●AV	34.9	33.5	31.1	150.0	7.9	10.0

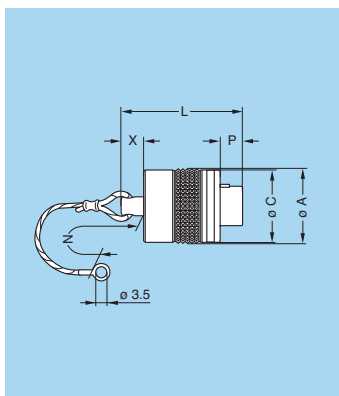

BME Blanking caps for fixed sockets

Part number	Dimensions (mm)					
	A	C	L	N	P	X
BME.MM.200.●AZ	11.1	10.7	19.5	60.0	5.5	4.0
BME.0M.200.●AZ	13.1	12.7	23.4	85.0	3.9	6.0
BME.1M.200.●AZ	14.6	14.2	23.4	85.0	3.9	6.0
BME.2M.200.●AZ	17.6	17.2	23.4	85.0	3.9	6.0
BME.3M.200.●AZ	19.6	19.2	23.4	120.0	3.9	6.0
BME.TM.200.●AZ	22.5	22.0	31.0	120.0	3.4	10.0
BME.4M.200.●AZ	25.0	24.5	31.0	120.0	3.4	10.0
BME.LM.200.●AZ	28.5	28.0	31.0	150.0	3.4	10.0
BME.5M.200.●AZ	34.0	33.5	31.0	150.0	3.4	10.0

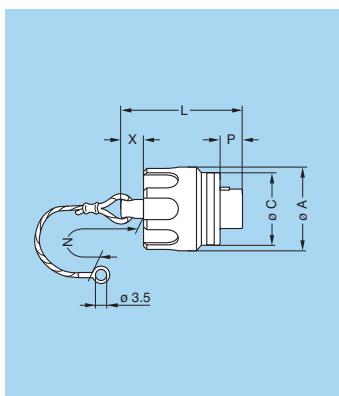

BGE Blanking caps for fixed sockets

Part number	Dimensions (mm)					
	A	C	L	N	P	X
BGE.MM.200.●AZ	12.0	10.7	19.5	60.0	5.5	4.0
BGE.0M.200.●AZ	14.4	12.7	23.4	85.0	3.9	6.0
BGE.1M.200.●AZ	15.9	14.2	23.4	85.0	3.9	6.0
BGE.2M.200.●AZ	18.9	17.2	23.4	85.0	3.9	6.0
BGE.3M.200.●AZ	20.9	19.2	23.4	120.0	3.9	6.0
BGE.TM.200.●AZ	23.4	22.0	31.0	120.0	3.4	10.0
BGE.4M.200.●AZ	25.9	24.5	31.0	120.0	3.4	10.0
BGE.LM.200.●AZ	29.4	28.0	31.0	150.0	3.4	10.0
BGE.5M.200.●AZ	34.9	33.5	31.0	150.0	3.4	10.0

BMF Blanking caps for free sockets

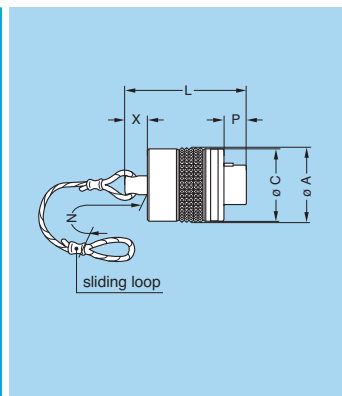

Part number	Dimensions (mm)					
	A	C	L	N	P	X
BMF.MM.200.◐AZ	11.1	10.7	19.5	60.0	5.5	4.0
BMF.0M.200.◐AZ	13.1	12.7	23.4	85.0	3.9	6.0
BMF.1M.200.◐AZ	14.6	14.2	23.4	85.0	3.9	6.0
BMF.2M.200.◐AZ	17.6	17.2	23.4	85.0	3.9	6.0
BMF.3M.200.◐AZ	19.6	19.2	23.4	120.0	3.9	6.0
BMF.TM.200.◐AZ	22.5	22.0	31.0	120.0	3.4	10.0
BMF.4M.200.◐AZ	25.0	24.5	31.0	120.0	3.4	10.0
BMF.LM.200.◐AZ	28.5	28.0	31.0	150.0	3.4	10.0
BMF.5M.200.◐AZ	34.0	33.5	31.0	150.0	3.4	10.0

BGF Blanking caps for free sockets

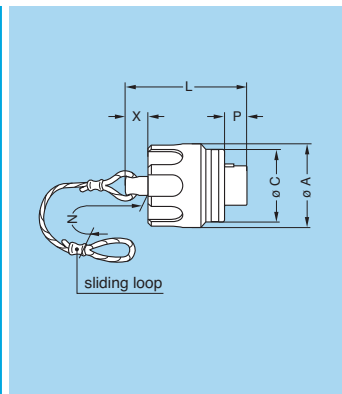

Part number	Dimensions (mm)					
	A	C	L	N	P	X
BGF.MM.200.◐AZ	12.0	10.7	19.5	60.0	5.5	4.0
BGF.0M.200.◐AZ	14.4	12.7	23.4	85.0	3.9	6.0
BGF.1M.200.◐AZ	15.9	14.2	23.4	85.0	3.9	6.0
BGF.2M.200.◐AZ	18.9	17.2	23.4	85.0	3.9	6.0
BGF.3M.200.◐AZ	20.9	19.2	23.4	120.0	3.9	6.0
BGF.TM.200.◐AZ	23.4	22.0	31.0	120.0	3.4	10.0
BGF.4M.200.◐AZ	25.9	24.5	31.0	120.0	3.4	10.0
BGF.LM.200.◐AZ	29.4	28.0	31.0	150.0	3.4	10.0
BGF.5M.200.◐AZ	34.9	33.5	31.0	150.0	3.4	10.0

BMK Blanking caps, large washer for EC◐/PE◐/HE◐ fixed sockets

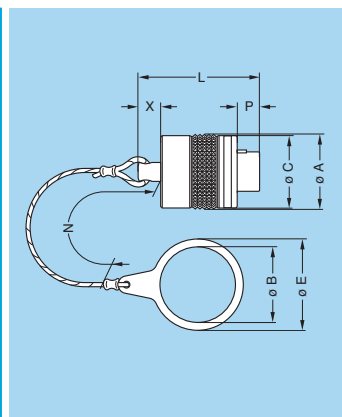

Part number	Dimensions (mm)							
	A	B	C	E	L	N	P	X
BMK.MM.200.◐AZ	11.1	10.1	10.7	14.0	19.5	60.0	5.5	4.0
BMK.0M.200.◐AZ	13.1	13.1	12.7	17.0	23.4	85.0	3.9	6.0
BMK.1M.200.◐AZ	14.6	14.1	14.2	18.0	23.4	85.0	3.9	6.0
BMK.2M.200.◐AZ	17.6	17.2	17.2	21.0	23.4	85.0	3.9	6.0
BMK.3M.200.◐AZ	19.6	19.2	19.2	23.0	23.4	120.0	3.9	6.0
BMK.TM.200.◐AZ	22.5	22.2	22.0	27.0	31.0	120.0	3.4	10.0
BMK.4M.200.◐AZ	25.0	24.2	24.5	29.0	31.0	120.0	3.4	10.0
BMK.LM.200.◐AZ	28.5	28.2	28.0	33.0	31.0	150.0	3.4	10.0
BMK.5M.200.◐AZ	34.0	33.2	33.5	38.0	31.0	150.0	3.4	10.0

BGK Blanking caps, large washer for EC◐/PE◐/HE◐ fixed sockets

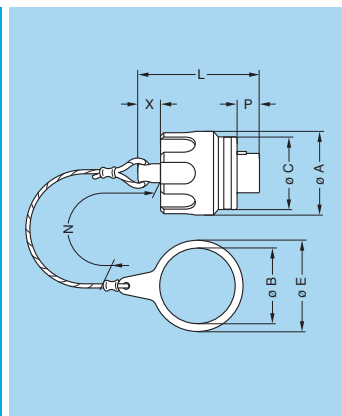
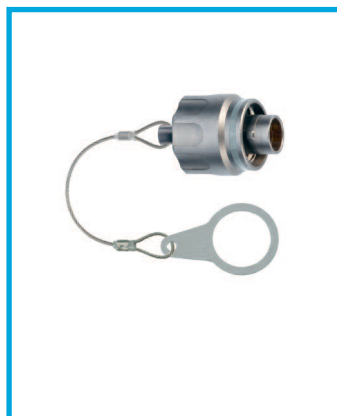

Part number	Dimensions (mm)							
	A	B	C	E	L	N	P	X
BGK.MM.200.◐AZ	12.0	10.1	10.7	14.0	19.5	60.0	5.5	4.0
BGK.0M.200.◐AZ	14.4	13.1	12.7	17.0	23.4	85.0	3.9	6.0
BGK.1M.200.◐AZ	15.9	14.1	14.2	18.0	23.4	85.0	3.9	6.0
BGK.2M.200.◐AZ	18.9	17.2	17.2	21.0	23.4	85.0	3.9	6.0
BGK.3M.200.◐AZ	20.9	19.2	19.2	23.0	23.4	120.0	3.9	6.0
BGK.TM.200.◐AZ	23.4	22.2	22.0	27.0	31.0	120.0	3.4	10.0
BGK.4M.200.◐AZ	25.9	24.2	24.5	29.0	31.0	120.0	3.4	10.0
BGK.LM.200.◐AZ	29.4	28.2	28.0	33.0	31.0	150.0	3.4	10.0
BGK.5M.200.◐AZ	34.9	33.2	33.5	38.0	31.0	150.0	3.4	10.0

Note: these caps are suitable for use with any alignment key configuration. The position «◐» of the part number indicates the housing material. See page 4.

DISCLAIMER The information contained within this catalog and the functions offered are intended to provide information about products. All reasonable efforts have been made to ensure the accuracy of the information. However, LEMO cannot be held responsible for any errors. LEMO does not warrant the accuracy and reserves the right to make changes to the catalog and its functions at any time without notice.

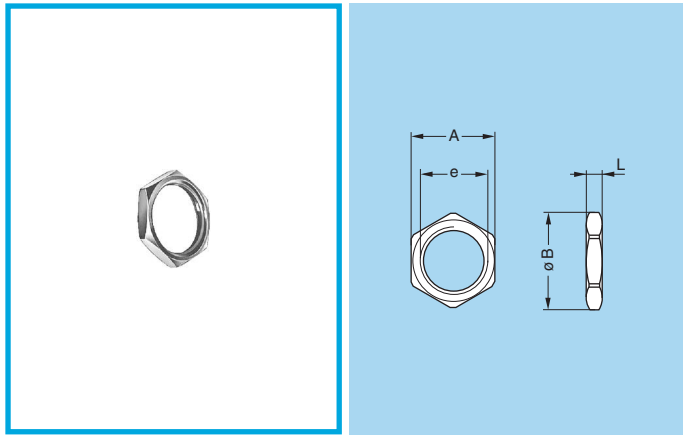

GEA Hexagonal nuts for EC• model

Part number	Series	Dimensions (mm)			
		A	B	e	L
GEA.MM.241.RL	MM	12	13.5	M10x0.50	2.5
GEA.0M.241.RL	0M	16	18.2	M13x0.75	2.5
GEA.0E.240.RL	1M	17	19.2	M14x1.00	2.5
GEA.2M.241.RL	2M	19	21.5	M17x1.00	3.0
GEA.3M.241.RL	3M	25	22.0	M19x1.00	3.0
GEA.TM.241.RL	TM	25	28.0	M22x1.00	3.0
GEA.4M.241.RL	4M	30	34.0	M24x1.00	3.0
GEA.LM.241.RL	LM	32	36.0	M28x1.00	3.0
GEA.5M.241.RL	5M	37	41.0	M33x1.00	3.0

● Material: Nickel-plated aluminium alloy (anthracite colour)

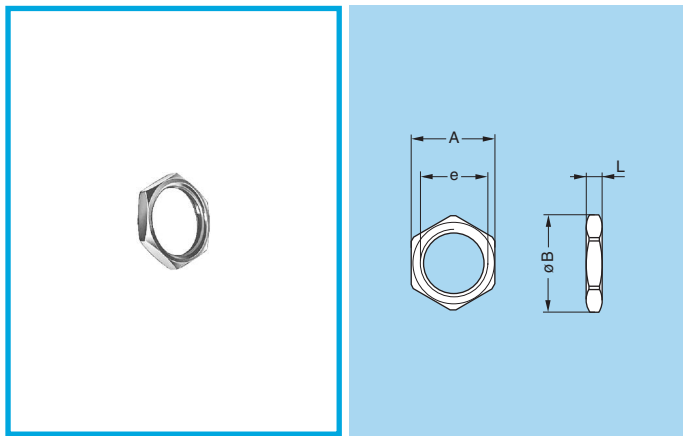

GEA Hexagonal nuts for EG• model

Part number	Series	Dimensions (mm)			
		A	B	e	L
GEA.00.240.RL	MM	9	10.2	M7x0.50	2.0
GEA.0S.240.RL	0M	11	12.4	M9x0.60	2.0
GEA.1M.240.RL	1M	13	14.5	M11x1.00	2.5
GEA.0E.240.RL	2M	17	19.2	M14x1.00	2.5
GEA.1E.240.RL	3M	19	21.5	M16x1.00	3.0
GEA.3S.240.RL	TM	22	25.0	M18x1.00	3.0
GEA.4M.240.RL	4M	25	28.0	M21x1.00	4.0
GEA.3E.240.RL	LM	30	34.0	M24x1.00	5.0
GEA.5M.240.RL	5M	36	40.5	M30x1.00	5.0

● Material: Nickel-plated aluminium alloy (anthracite colour)

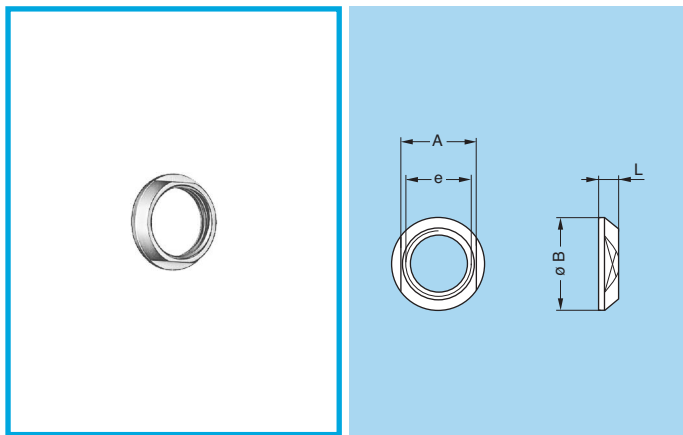

GEC Conical nut for models HE•, EC•, PE•

Part number	Series	Dimensions (mm)			
		A	B	e	L
GEC.MM.240.RN	MM	11	14	M10x0.50	2.5
GEC.0M.240.RN	0M	14	17	M13x0.75	3.2
GEC.0E.240.RN	1M	16	18	M14x1.00	3.0
GEC.2M.240.RN	2M	18	21	M17x1.00	3.2
GEC.3M.240.RN	3M	20	23	M19x1.00	3.2
GEC.TM.240.RN	TM	23	27	M22x1.00	5.0
GEC.4M.240.RN	4M	25	29	M24x1.00	5.0
GEC.LM.240.RN	LM	29	33	M28x1.00	5.0
GEC.5M.240.RN	5M	34	38	M33x1.00	5.0

● Material: Nickel-plated aluminium alloy (anthracite colour)



FGN M series constant force spring clips

A range of constant force spring clips are available for use with M Series connectors, which permits repair of cable terminations without having to discard any of the existing braid shield system. When used in conjunction with LEMO heatshrink boots, a fully sealed termination is achieved. An additional benefit of the constant force spring is that it provides excellent resistance to shock or vibration due to its self-tensioning properties.

Part number	Series	Braid grounding location diameter (mm)
FGN.0M.185.AZ	0M / 1M / 2M	8.0 / 9.7 / 13.0
FGN.3M.185.AZ	3M / TM	15.0 / 16.7
FGN.5M.185.AZ	4M / LM / 5M	19.5 / 22.7 / 28.5

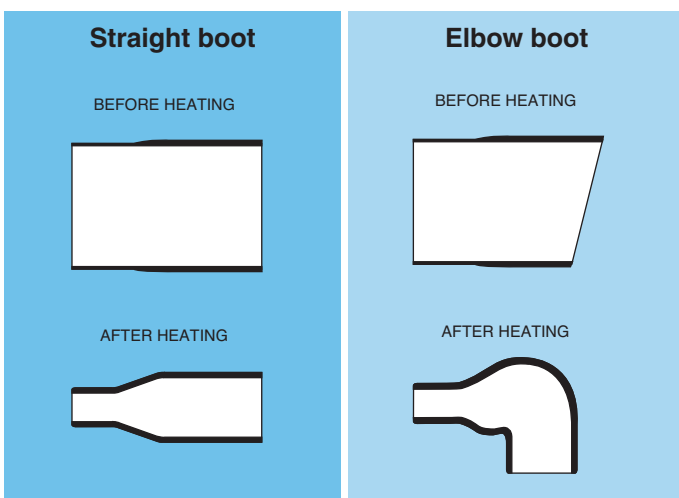

Heatshrink boot

Supplier	Series	Part number		Note	cable ø min. (mm)
		Straight	Elbow 90°		
LEMO	MM	GMA.10.290.DN	GHA.10.210.DN	2)	2.2
	0M-2M	202 A 111-25/86	222 A 111-25/86	1)	3.8
Raychem®	2M-4M	202 A 121-25/86	222 A 121-25/86	1)	5.3
	4M-5M	202 A 142-25/86	222 A 142-25/86	1)	7.4

Note:

- 1) modified elastomer resistant to fluids with hot melt sealant.
- 2) elastomer resistant to fluids. We recommend a thermosetting sealant with this type of boot.

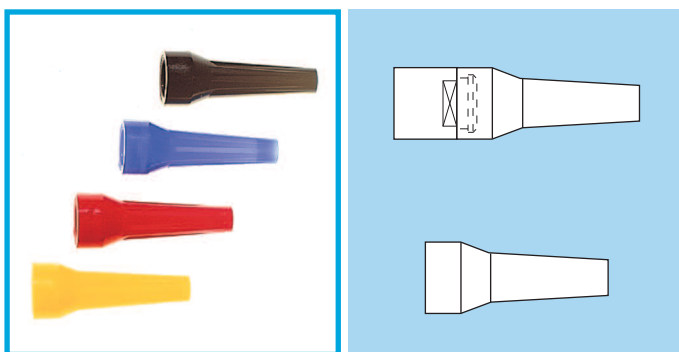

GMA Bend relief (for M series fibre optic model only)

A bend relief made from thermoplastic polyurethane elastomer can be fitted over LEMO plugs and sockets that are supplied with nut for fitting such bend relief.

An other bend relief has been designed for connectors used in applications at high temperature or requiring vapour sterilization. These bend reliefs are different from previous ones as for their material, a silicone elastomer which is noted for its retention of flexibility over a wide temperature range.

Part number (Polyurethane)	Series	Part number (Silicone)
GMA.2B.0**.DG	2M	GMA.2B.0**.RG
GMA.4B.0**.DG	5M	GMA.4B.0**.RG

Note:

Please see unipole/multipole catalogue for bend relief dimensions. The last letter «G» of the part number indicates the grey colour of the bend relief. For ordering a bend relief with another colour, see table on the right and replace the letter «G» by the letter of the required colour.

Main characteristics

- Material: TPU (Thermoplastic Polyurethane)
- Temperature range in dry atmosphere: -40°C +80°C
- Material: Silicone elastomer VMQ
- Temperature range in dry atmosphere: -60°C +200°C
- Temperature range in water steam: +140°C

Ref.	Colour
A	blue
B	white
G	grey

Ref.	Colour
J	yellow
M	brown
N	black

Ref.	Colour
R	red
S	orange
V	green

DISCLAIMER The information contained within this catalog and the functions offered are intended to provide information about products. All reasonable efforts have been made to ensure the accuracy of the information. However, LEMO cannot be held responsible for any errors. LEMO does not warrant the accuracy and reserves the right to make changes to the catalog and its functions at any time without notice.

Tooling

DCE Positioners for crimp contacts

Male



Contact		Positioners part number
Contact ø	Size	For male contacts
1.3	0M-5M	DCE.91.130.5MVC
0.9	0M-5M	DCE.91.090.5MVC
0.7	0M-5M	DCE.91.070.5MVC
0.5	MM	DCE.91.050.0VC

Female



Contact		Positioners part number
Contact ø	Size	For female contacts
1.3	0M-5M	DCE.91.130.5MVM
0.9	0M-3M	DCE.91.090.3MVM
	TM-5M	DCE.91.09T.5MVM
0.7	0M-3M	DCE.91.070.3MVM
	TM-5M	DCE.91.07T.5MVM
0.5	MM	DCE.91.050.0VM

These positioners are suitable for use with both manual and pneumatic crimping tools according to the MIL-C-22520/7-01 standard.

DCF Extractors for crimp contacts

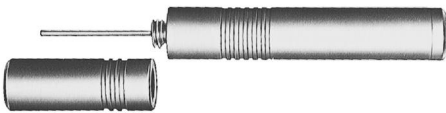

Contact ø	Part number
1.3	DCF.93.131.4LT
0.9	DCF.93.090.4LT
0.7	DCF.93.070.4LT
0.5	DCF.91.050.2LT

Note: this model is used for male and female contacts.

DCV Female contact insertion tool



Contact ø	Part number
1.3	DCV.13.05M.LA
0.9	DCV.09.05M.LA
0.7	DCV.07.05M.LA

Front conical nut



Torque wrench



DCM Front conical nut tightening tools

Part number		Series	Torque (Nm)	For models
Front conical nut	Torque wrench			
DCM.65.120.AZ	DCM.65.000.4PA	MM	1.0	EC●, HE●, PE●
DCM.65.140.AZ		0M	1.0	EC●, HE●, PE●
DCM.65.160.AZ		1M	1.5	EC●, HE●, PE●
DCM.65.180.AZ		2M	2.0	EC●, HE●, PE●
DCM.65.200.AZ	DCM.65.040.8PA	3M	2.5	EC●, HE●, PE●
DCM.65.230.AZ		TM	4.0	EC●, HE●, PE●
DCM.65.250.AZ		4M	5.0	EC●, HE●, PE●
DCM.65.290.AZ		LM	6.5	EC●, HE●, PE●
DCM.65.340.AZ		5M	8.0	EC●, HE●, PE●

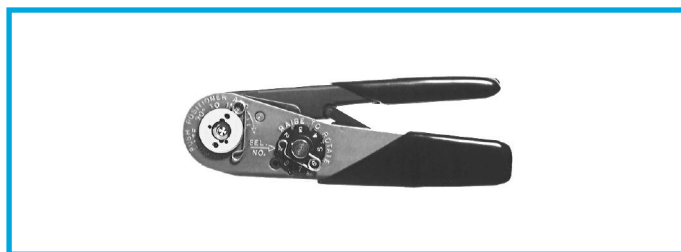

DPC Manual crimping tool

Part number
DPC.91.701.V

According to specification MIL-C-22520/7-01.
For LEMO contacts \varnothing 0.5-0.7-0.9-1.3 mm



Banding tool

	Part number		
	GLEN-AIR®	TIE-DEX®	AXON®
Banding tool	600-061	A30199	ACDBS100
Tie wrap	600-057	A31189	AXCLOZ

Note: the banding tool is to be used with screened cables to ensure a good ground contact.

Panel Cut-Out

Cut-outs

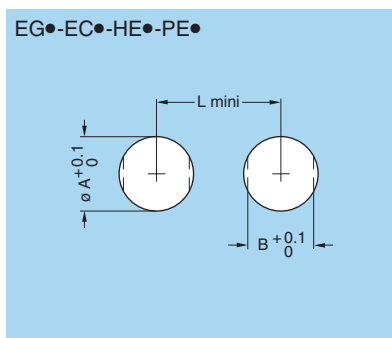

Series	EG●			EC●/HE●/PE●		
	\varnothing A	B	L	\varnothing A	B	L
MM	7.1	6.4	12.5	10.1	9.1	16.0
0M	9.1	8.3	14.5	13.1	11.6	20.0
1M	11.1	9.6	17.2	14.1	12.6	21.0
2M	14.1	12.6	20.5	17.1	15.6	24.0
3M	16.1	14.6	23.0	19.1	17.6	27.0
TM	18.1	16.6	27.0	22.1	20.6	31.5
4M	21.1	19.6	30.0	24.1	22.6	35.5
LM	24.1	22.6	32.0	28.1	26.6	36.5
5M	30.1	28.6	41.0	33.1	31.6	41.0

Mounting nut torque (on panel)

Series	Torque (Nm)
MM	1.0
0M	1.0
1M	1.5
2M	2.0
3M	2.5
TM	4.0
4M	5.0
LM	6.5
5M	8.0

Cut-outs

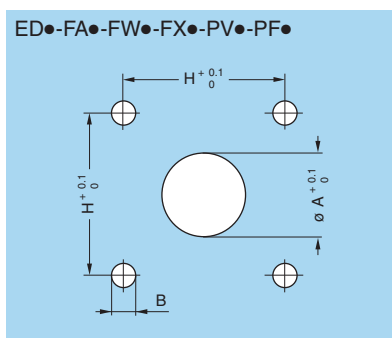

Series	ED●			FA●/FW●/FX●			PV●			PF●		
	\varnothing A	B	H	\varnothing A	B	H	\varnothing A	B	H	\varnothing A	B	H
MM	5.0	M2.5	9.5	9.6	M2.5	12.0	11.8	M2.5	12.0	7.9	M2.5	9.5
0M	5.1	M2.5	11.0	12.3	M2.5	15.1	15.0	M2.5	15.1	10.8	M2.5	11.0
1M	6.1	M3.0	12.9	13.8	M3.0	18.3	17.0	M3.0	18.3	12.5	M3.0	12.9
2M	9.1	M3.0	15.1	16.8	M3.0	20.6	20.0	M3.0	20.6	15.6	M3.0	15.1
3M	11.1	M3.0	16.6	18.8	M3.0	20.6	22.0	M3.0	23.0	18.1	M3.0	16.6
TM	12.5	M3.0	18.3	21.6	M3.0	23.0	25.0	M3.0	24.6	19.9	M3.0	18.3
4M	14.1	M3.0	20.6	24.1	M3.0	24.6	28.0	M3.0	27.0	22.7	M3.0	20.6
LM	18.1	M3.0	23.0	27.6	M3.0	27.0	31.0	M3.0	29.4	25.9	M3.0	23.0
5M	23.2	M3.0	27.0	33.1	M3.0	29.4	38.0	M3.0	34.9	33.1	M3.0	29.4

Cut-outs

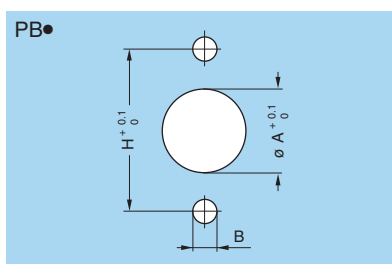

Series	PB●		
	\varnothing A	B	H
MM	11.8	M2.5	16.2
0M	15.0	M3.0	21.4
1M	17.0	M3.0	23.4
2M	20.0	M3.0	26.4
3M	22.0	M3.0	29.0

Series	PB●		
	\varnothing A	B	H
TM	25.0	M3.0	32.5
4M	28.0	M3.0	35.0
LM	31.0	M3.0	38.0
5M	38.0	M3.0	45.0

DISCLAIMER The information contained within this catalog and the functions offered are intended to provide information about products. All reasonable efforts have been made to ensure the accuracy of the information. However, LEMO cannot be held responsible for any errors. LEMO does not warrant the accuracy and reserves the right to make changes to the catalog and its functions at any time without notice.

PCB drilling pattern

Fixed socket with straight print contact

For HE● models

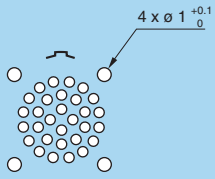

For EG●, EC● and ED● models



MM.303

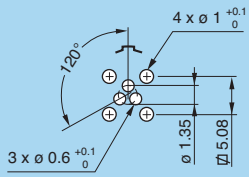

MM.304

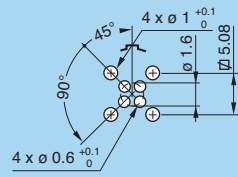

OM.302

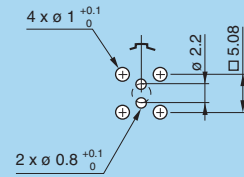

OM.303

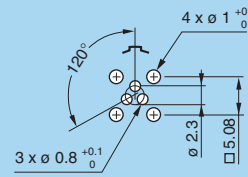

OM.304

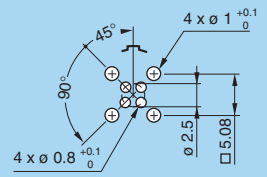

OM.305

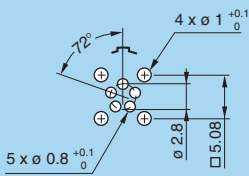

1M.302

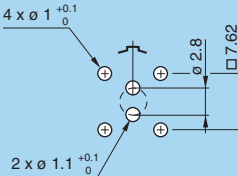

1M.303

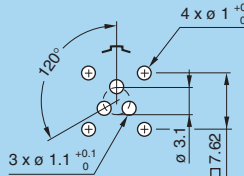

1M.304•R

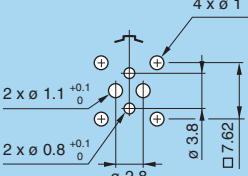

1M.305

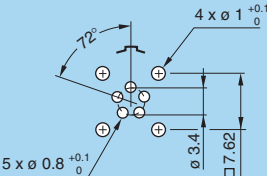

1M.307

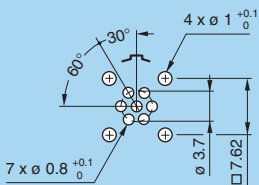

1M.308

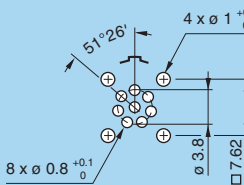

2M.304

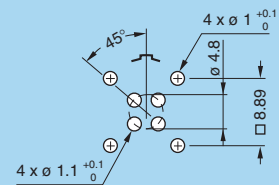

2M.306•R

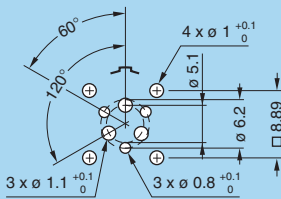

2M.308

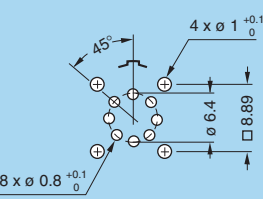

2M.308•R

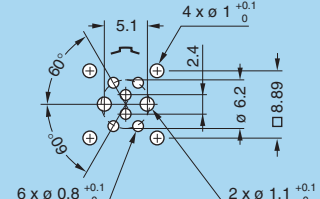

2M.310

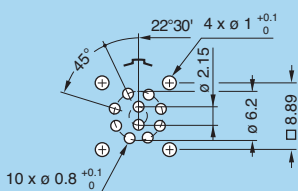

2M.310•R

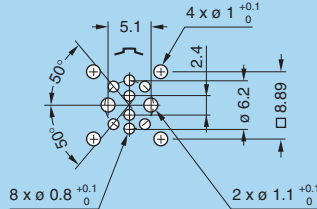

2M.312

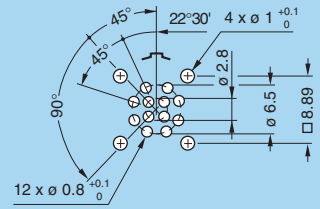

DISCLAIMER The information contained within this catalog and the functions offered are intended to provide information about products. All reasonable efforts have been made to ensure the accuracy of the information. However, LEMO cannot be held responsible for any errors. LEMO does not warrant the accuracy and reserves the right to make changes to the catalog and its functions at any time without notice.

2M.319

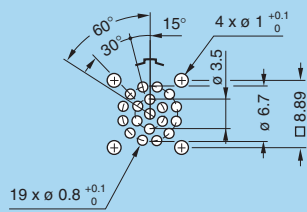

3M.322

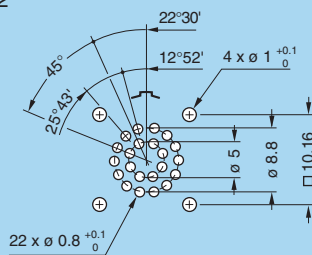

3M.330

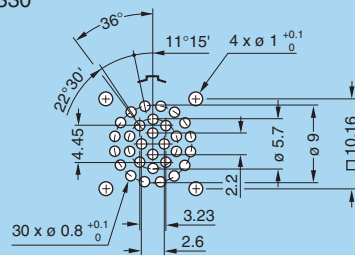

TM.325

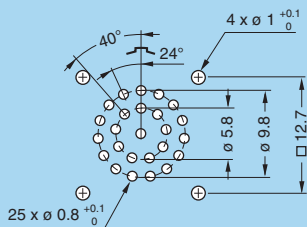

TM.340

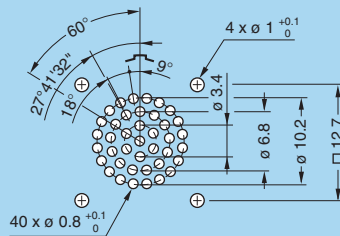

4M.340

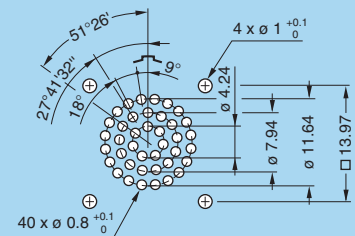

4M.348

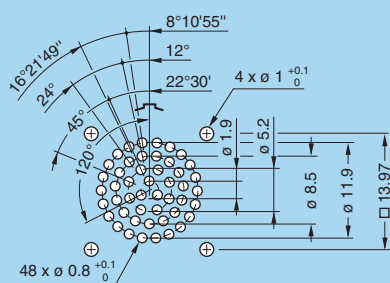

LM.355

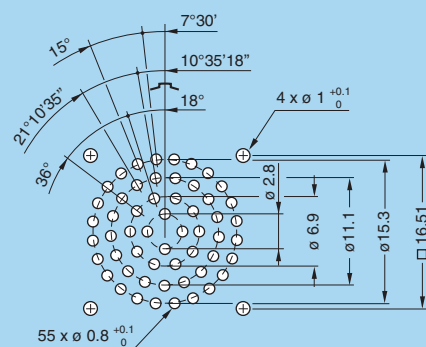

LM.368

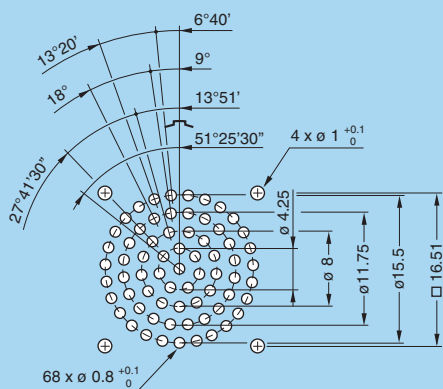

5M.366

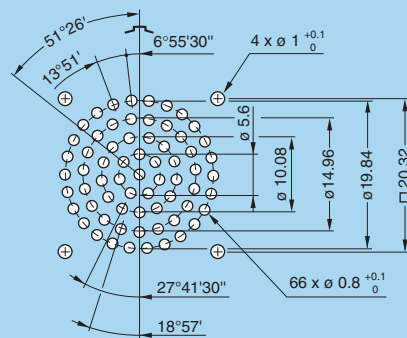

5M.114

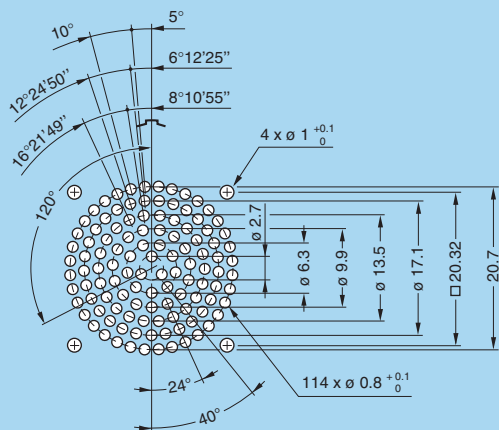

Assembly instructions for plugs and sockets

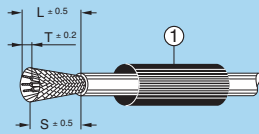
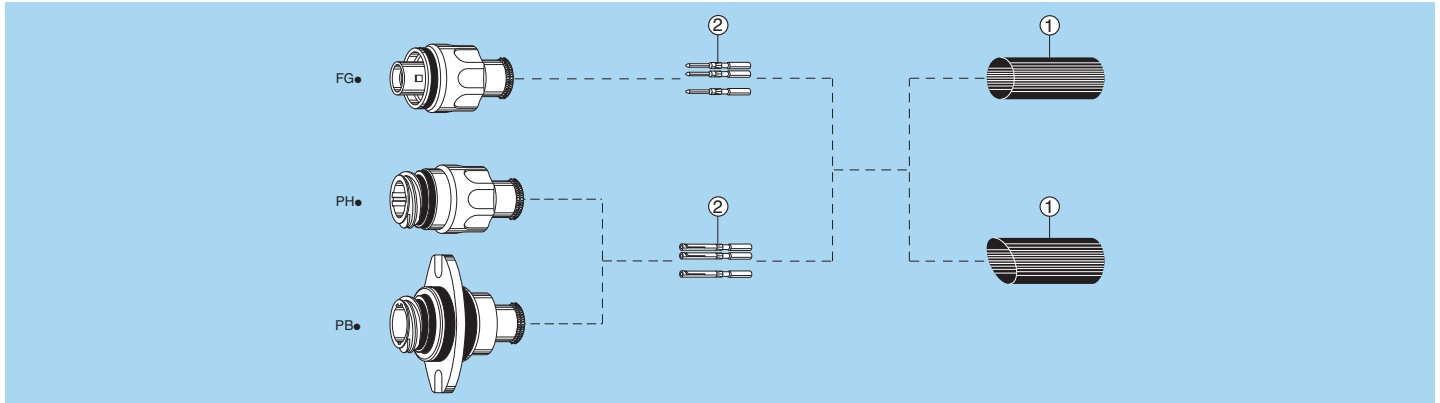

1. Cable preparation

First place the heatshrink boot ① over the cable. Strip the cable according to dimensions of the table, then widen the shield.

Series	L	S	T
MM	14	9	3.0
0M to 5M	20	15	3.5

Note: dimensions are in mm.

2. Cable termination

2.1 With shielded cables, widen and pull the shield all the way to the back. Fix the appropriate positioner onto the crimping tool and set the selector to the number corresponding to the AWG of the conductor used as indicated on the positioner label.

Fit the conductor into the contact ②; make sure it is visible through the contact's inspection hole.

Slide the conductor-contact assembly into the open crimping tool; make sure that the contact is pushed fully into the positioner. Close the tool. Remove from crimping tool and check that conductor is secure in contact and shows in inspection hole.

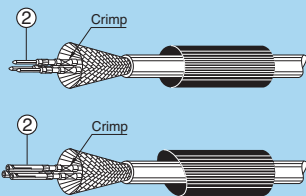

2.2 Arrange the conductor-contact assemblies according to the markings, into the rear cable seal.

Push them deeply into the insulator, using tweezers if necessary; check that all the contacts are correctly located in the insulator: 1) by verifying the alignment of the contacts at the front of the insulator and 2) by gently pulling on each conductor.

Verification should also be made using the appropriate retention testing tool.

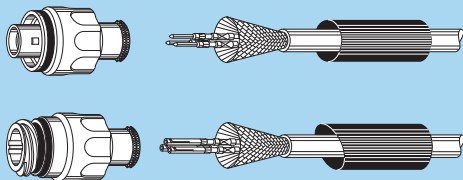

2.3 Bring the shield around the rear of connector.

Secure it with a band-it tie-wrap (not furnished) to fix the shield in place. Cut off the possible shield surplus.

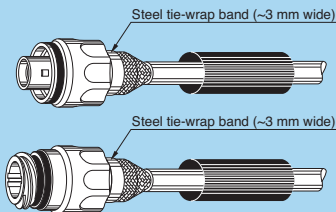

2.4 Put the heatshrink boot in place and heat gently until it retracts.

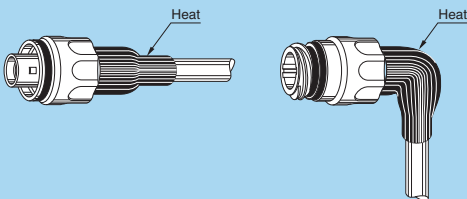

Assembly instructions for plugs and sockets (with optional mold stop)

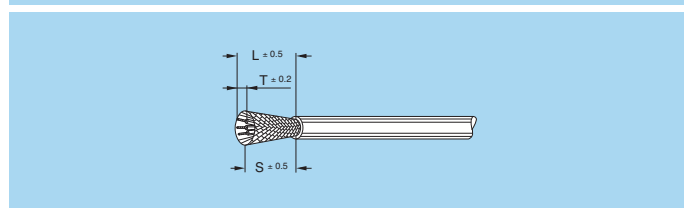
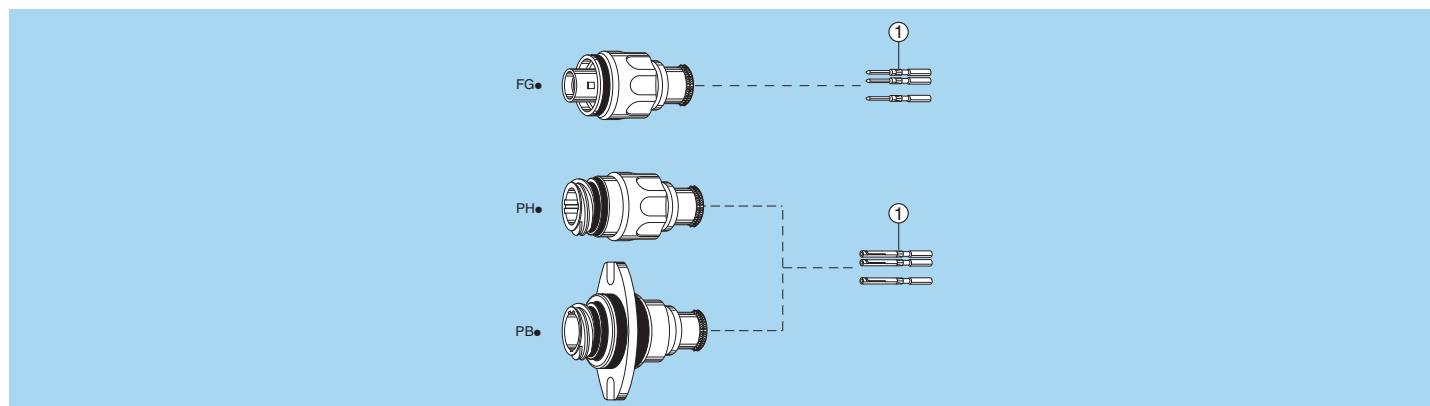

1. Cable preparation

Strip the cable according to dimensions of the table, then widen the shield.

Series	L	S	T
MM	14	9	3.0
0M to 5M	20	15	3.5

Note: dimensions are in mm.

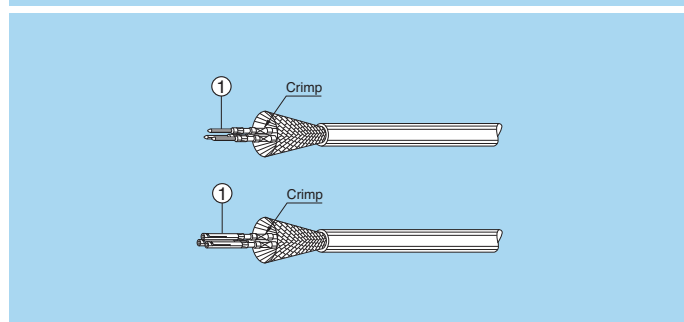

2. Cable termination

2.1 With shielded cables, widen and pull the shield all the way to the back. Fix the appropriate positioner onto the crimping tool and set the selector to the number corresponding to the AWG of the conductor used as indicated on the positioner label.

Fit the conductor into the contact ①; make sure it is visible through the contact's inspection hole.

Slide the conductor-contact assembly into the open crimping tool; make sure that the contact is pushed fully into the positioner. Close the tool. Remove from crimping tool and check that conductor is secure in contact and shows in inspection hole.

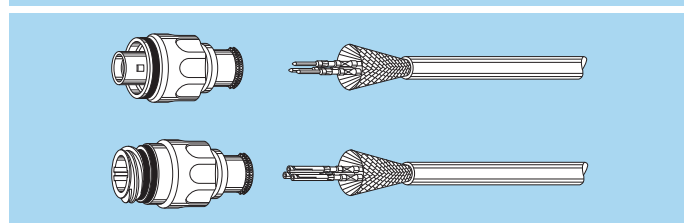

2.2 Arrange the conductor-contact assemblies according to the markings, into the rear cable seal.

Push them deeply into the insulator, using tweezers if necessary; check that all the contacts are correctly located in the insulator: 1) by verifying the alignment of the contacts at the front of the insulator and 2) by gently pulling on each conductor.

Verification should also be made using the appropriate retention testing tool.

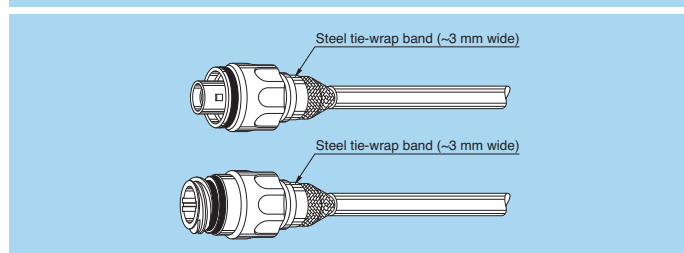

2.3 Bring the shield around the rear of connector until the mold stop.

Secure it with a band-it tie-wrap (not furnished) to fix the shield in place. Cut off the possible shield surplus.

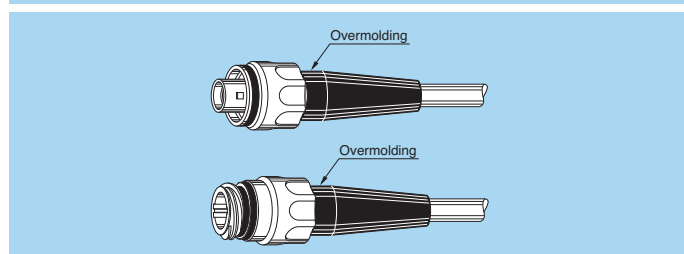

2.4 Custom overmold cable assembly.

DISCLAIMER The information contained within this catalog and the functions offered are intended to provide information about products. All reasonable efforts have been made to ensure the accuracy of the information. However, LEMO cannot be held responsible for any errors. LEMO does not warrant the accuracy and reserves the right to make changes to the catalog and its functions at any time without notice.

Notes

Product safety notice

PLEASE READ AND FOLLOW ALL INSTRUCTIONS CAREFULLY AND CONSULT ALL RELEVANT NATIONAL AND INTERNATIONAL SAFETY REGULATIONS FOR YOUR APPLICATION. IMPROPER HANDLING, CABLE ASSEMBLY, OR WRONG USE OF CONNECTORS CAN RESULT IN HAZARDOUS SITUATIONS.

1. SHOCK AND FIRE HAZARD

Incorrect wiring, the use of damaged components, presence of foreign objects (such as metal debris), and / or residue (such as cleaning fluids), can result in short circuits, overheating, and / or risk of electric shock. Mated components should never be disconnected while live as this may result in an exposed electric arc and local overheating, resulting in possible damage to components.

2. HANDLING

Connectors and their components should be visually inspected for damage prior to installation and assembly. Suspect components should be rejected or returned to the factory for verification. Connector assembly and installation should only be carried out by properly trained personnel. Proper tools must be used during installation and / or assembly in order to obtain safe and reliable performance.

3. USE

Connectors with exposed contacts should never be live (or on the current supply side of a circuit). Under general conditions voltages above 30 VAC and 42 VDC are considered hazardous and proper measures should be taken to eliminate all risk of transmission of such voltages to any exposed metal part of the connector.

4. TEST AND OPERATING VOLTAGES

The maximum admissible operating voltage depends upon the national or international standards in force for the application in question. Air and creepage distances impact the operating voltage; reference values are indicated in the catalog however these may be influenced by PC board design and / or wiring harnesses. The test voltage indicated in the catalog is 75% of the mean breakdown voltage; the test is applied at 500 V/s and the test duration is 1 minute.

5. CE MARKING

CE marking  means that the appliance or equipment bearing it complies with the protection requirements of one or several European safety directives.

CE marking  applies to complete products or equipment, **but not to electromechanical components, such as connectors.**

6. PRODUCT IMPROVEMENTS

The LEMO Group reserves the right to modify and improve to our products or specifications without providing prior notification.

Data subject to change

No reproduction or use without express permission of editorial or pictorial content, in any manner. LEMO reserve the right at all times to modify and improve specifications without any notification.

DISCLAIMER The information contained within this catalog and the functions offered are intended to provide information about products. All reasonable efforts have been made to ensure the accuracy of the information. However, LEMO cannot be held responsible for any errors. LEMO does not warrant the accuracy and reserves the right to make changes to the catalog and its functions at any time without notice.

LEMO HEADQUARTERS

SWITZERLAND

LEMO SA

Chemin des Champs-Courbes 28 - P.O. Box 194 - CH-1024 Ecublens
Tel. (+41 21) 695 16 00 - Fax (+41 21) 695 16 02 - e-mail: info@lemo.com

LEMO SUBSIDIARIES

AUSTRIA

LEMO Elektronik GesmbH

Lemböckgasse 49/E6-3
1230 Wien
Tel: (+43 1) 914 23 20 0
Fax: (+43 1) 914 23 20 11
sales@lemo.at

BRAZIL

LEMO Latin America Ltda

Av. José Rocha Bonfim,
214 Salas 224 / 225
Condomínio Praça Capital
Ed. Chicago
Campinas / SP - Brasil 13080-650
Tel: +55 (11) 98689 4736
info-la@lemo.com

CANADA

LEMO Canada Inc

44 East Beaver Creek Road, unit 20
Richmond Hill, Ontario L4B 1G8
Tel: (+1 905) 889 56 78
Fax: (+1 905) 889 49 70
info-canada@lemo.com

CHINA / HONG KONG

LEMO Electronics (Shanghai) Co., Ltd

First Floor, Block E,
18 Jindian Road, Pudong
Shanghai, China, 201206
Tel: (+86 21) 5899 7721
Fax: (+86 21) 5899 7727
cn.sales@lemo.com

DENMARK

LEMO Denmark A/S

Gammel Mosevej 46
2820 Gentofte
Tel: (+45) 45 20 44 00
Fax: (+45) 45 20 44 01
info-dk@lemo.com

FRANCE

LEMO France Sàrl

24/28 Avenue Graham Bell
Bâtiment Balthus 4
Bussy Saint Georges
77607 Marne la Vallée Cedex 3
Tel: (+33 1) 60 94 60 94
Fax: (+33 1) 60 94 60 90
info-fr@lemo.com

GERMANY

LEMO Elektronik GmbH

Hanns-Schwindt-Str. 6
81829 München
Tel: (+49 89) 42 77 03
Fax: (+49 89) 420 21 92
info@lemo.de

HUNGARY

REDEL Elektronika Kft

Nagysándor József u. 6-12
1201 Budapest
Tel: (+36 1) 421 47 10
Fax: (+36 1) 421 47 57
info-hu@lemo.com

ITALY

LEMO Italia srl

Viale Lunigiana 25
20125 Milano
Tel: (+39 02) 66 71 10 46
Fax: (+39 02) 66 71 10 66
sales.it@lemo.com

JAPAN

LEMO Japan Ltd

2-7-22, Mita,
Minato-ku, Tokyo, 108-0073
Tel: (+81 3) 54 46 55 10
Fax: (+81 3) 54 46 55 11
lemoinfo@lemo.co.jp

MIDDLE EAST

LEMO Middle East Gen. Trad. LLC

Concorde Tower 6th Floor,
Dubai Media City, P.O. Box 126732
Dubai, United Arab Emirates
Tel: +971 55 222 36 77
info-me@lemo.com

NETHERLANDS / BELGIUM

LEMO Connectors Benelux

De Trompet 1060
1967 DA Heemskerk
Tel: (+31) 251 25 78 20
Fax: (+31) 251 25 78 21
info@lemo.nl

NORWAY / ICELAND

LEMO Norway A/S

Stanseveien 6B, 0975 Oslo
Tel: (+47) 22 91 70 40
Fax: (+47) 22 91 70 41
info-no@lemo.com

SINGAPORE

LEMO Asia Pte Ltd

4 Leng Kee Road,
#06-09 SiS Building
Singapore 159088
Tel: (+65) 6476 0672
Fax: (+65) 6474 0672
sg.sales@lemo.com

SPAIN / PORTUGAL

IBERLEMO SAU

Brasil, 45, 08402 Granollers
Barcelona
Tel: (+34 93) 860 44 20
Fax: (+34 93) 879 10 77
info-es@lemo.com

SWEDEN / FINLAND

LEMO Nordic AB

Mariehällsvägen 39A
168 65 Bromma
Tel: (+46 8) 635 60 60
Fax: (+46 8) 635 60 61
info-se@lemo.com

SWITZERLAND

LEMO Verkauf AG

Grundstrasse 22 B
6343 Rotkreuz
Tel: (+41 41) 790 49 40
ch.sales@lemo.com

UNITED KINGDOM

LEMO UK Ltd

12-20 North Street, Worthing,
West Sussex, BN11 1DU
Tel: (+44 1903) 23 45 43
lemouk@lemo.com

USA

LEMO USA Inc

P.O. Box 2408
Rohnert Park, CA 94927-2408
Tel: (+1 707) 578 88 11
(+1 800) 444 53 66
Fax: (+1 707) 578 08 69
info-US@lemo.com

LEMO DISTRIBUTORS

AUSTRALIA, CHILE, CZECH REPUBLIC, GREECE, INDIA, ISRAEL,
NEW ZEALAND, POLAND, RUSSIA, SOUTH AFRICA, SOUTH KOREA,
TAIWAN, TURKEY, UKRAINE

www.lemo.com

