

LOC	DIST	P	F	REVISIONS			
ZONE	LTR	DESCRIPTION	DATE	APPD			
AJ	16			D	REVISED PER 0220-0219-96	5-22-96	JG

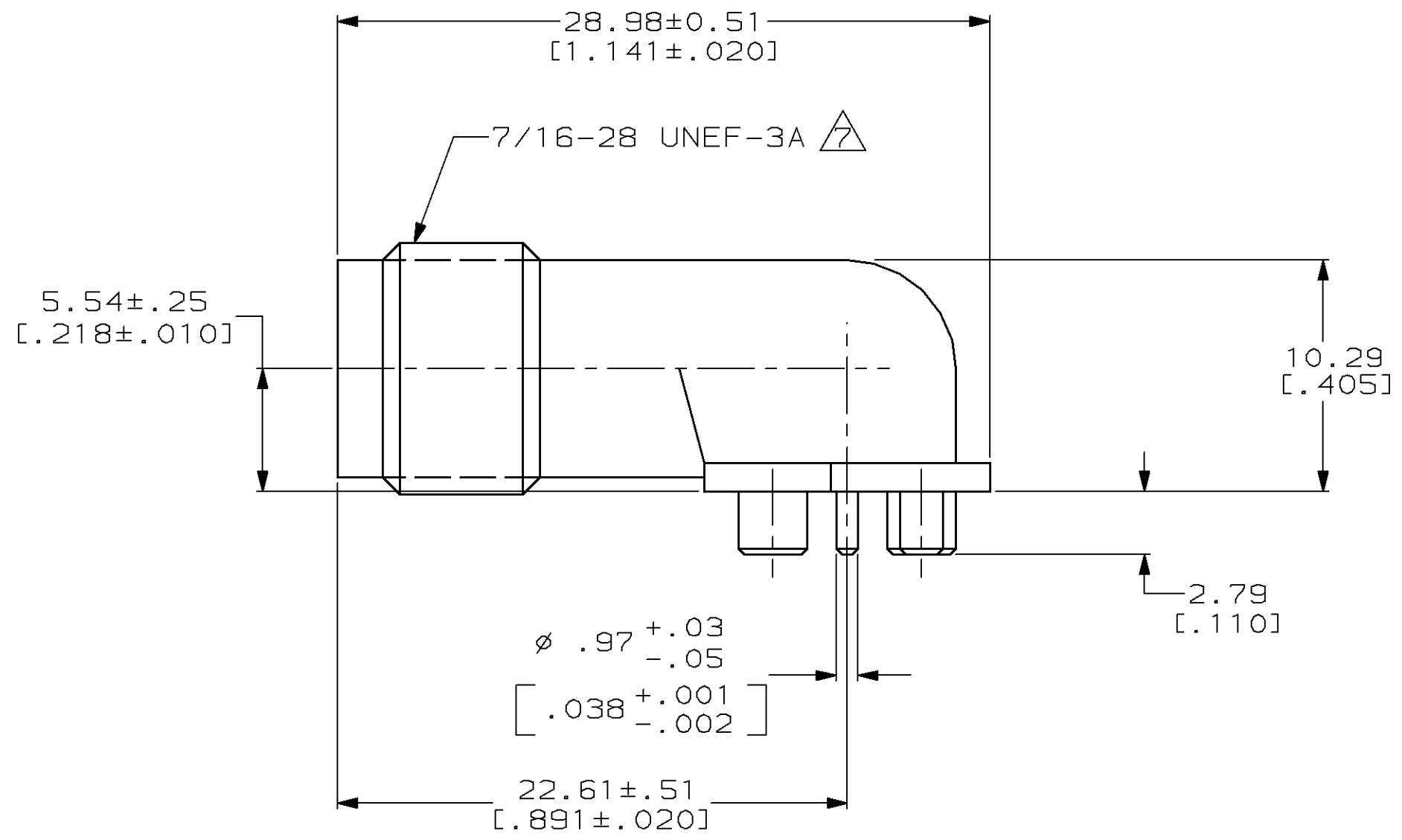

- ① ZINC PER QQ-Z-363
- ② BERYLLIUM COPPER PER QQ-C-530
- ③ PTFE PER MIL-P-19468
- ④ NICKEL PLATE PER QQ-N-290, .0051 [.000200] MINIMUM THICKNESS
- ⑤ GOLD PLATE PER MIL-G-45204 .0013 [.000050] MINIMUM THICKNESS
- 6. INTERMATEABLE WITH PRODUCT PER MIL-C-39012
- ⑦ MAJOR THREAD DIAMETER TO BE .437/.427, DIMENSION TO BE MEASURED 90° OPPOSITE THE PARTING LINE.
- ⑧ POLYMETHYLPENTENE, GENERAL PURPOSE

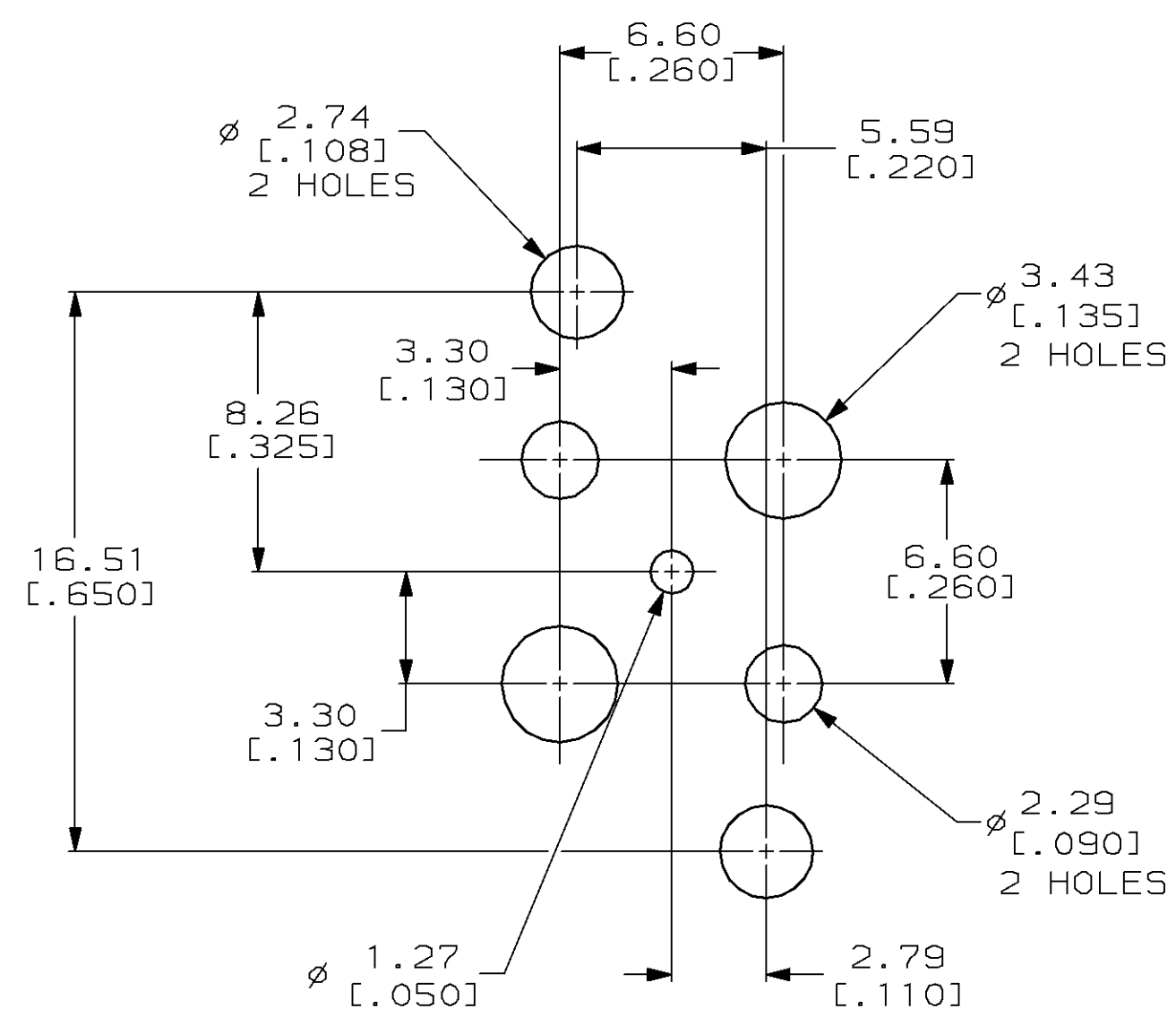
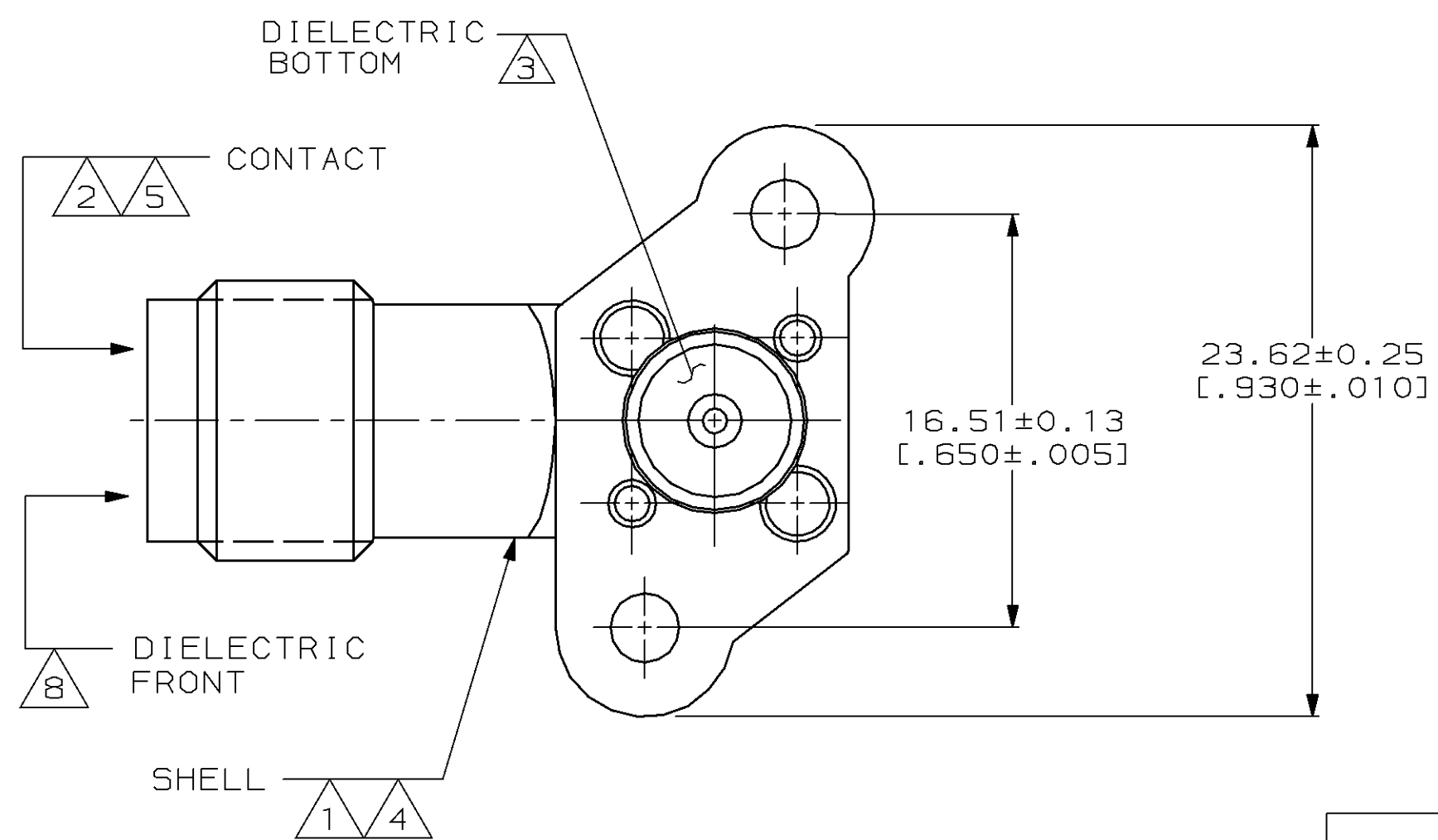

413933-1
PART NUMBER

DO NOT SCALE PRINT. UNLESS SPECIFIED DIMENSIONS IN mm [INCHES] TOLERANCES ON : 2 PLC DEC ± 0.08 [.003] 3 PLC DEC ± - ANGLES ± -		DR 8-21-90 B. WERNER		AMP Incorporated Harrisburg, PA 17105-3608	
MATERIAL		CHK 9-4-90 R.E.RUTH			
FINISH		APPD 9-4-90 R. HENRY		NAME	
		APPD 9-4-90 B. WERNER		JACK, RIGHT ANGLE, PCB, 50 OHM, SERIES TNC	
		PRODUCT SPEC		DRAWING NO	
		APPLICATION SPEC		413933	
		WEIGHT -		CAGE CODE	
				00779	
				SCALE	
				4:1	
				SHEET	
				1 OF 1	