

©1963 BY AMP INCORPORATED. ALL RIGHTS RESERVED. AMP PRODUCTS COVERED BY PATENTS AND/OR PATENTS PENDING.

REVISIONS

SYM	ZONE	DESCRIPTION	DATE	APPROVAL
G ₁		REV. PER ECN D-644	9-17-75	JW
H		OBSOLETED - 1 PER ECN E-876	2-17-77	JRS
J		REV. PER ECN E-928	4/14/77	AH
K		REV PER DF-3282	5/3/90	TW
L		REV PER ELD-05-001412	05/05	AA
M		REV PER ECO-05-005359	11-14-05	PY/DE

NUMBER 202305

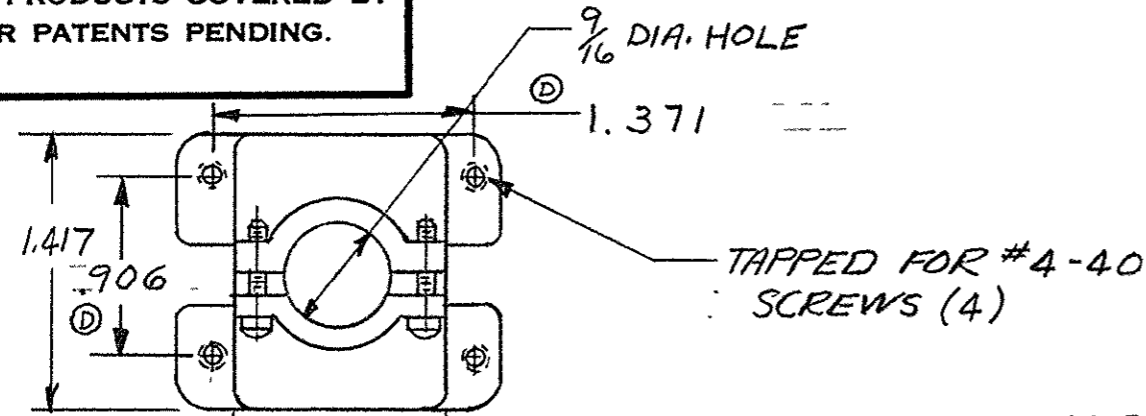

AMP STAMP AND PART NO. LOCATED IN THIS AREA.

ZINC PLATED COLD ROLLED STL-SCREW (2)
 FILLISTER HEAD - 3 ONLY
 PASSIVATED STAINLESS STEEL SCREW (2)
 FILLISTER HEAD 5-3 ONLY

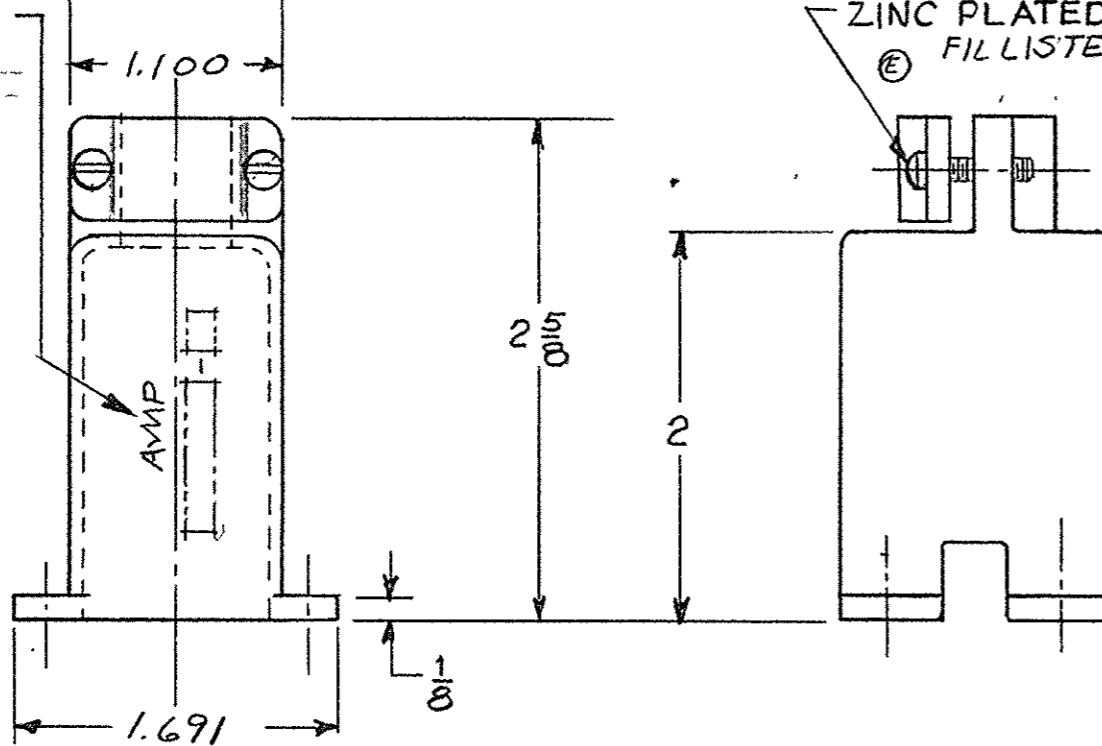

5-202305-3	FINISH: PLATED ELECTROLESS NICKEL PER SAE-AMS-L-26074 .000400-.000800 THK (NO INTENTIONAL ADDITIONS OF LEAD OR CADMIUM PER DFE STD 230-700)
ASSY NO.	FINISH
202305-1	ZINC PLATE PER QQ-Z-325 TYPE II CLASS 3 COLORLESS SUPPLEMENTARY CHROMATE (H)
202305-2	OLIVE DRAB CADMIUM PLATE PER QQ-P-416a CLASS 2 TYPE II (C)
202305-3	ZINC PLATE PER QQ-Z-325 TYPE 3 CLASS 3 COLORLESS SUPPLEMENTARY CHROMATE
202305-4	SAME AS -1 EXCEPT FILLISTER HEAD SCREWS (E)

SUPERSEDED BY 5-202305-3

QTY REQD	PART OR IDENTIFYING NO.	NOMENCLATURE OR DESCRIPTION
LIST OF MATERIALS OR PARTS LIST		
UNLESS OTHERWISE SPECIFIED DIMENSIONS ARE IN INCHES TOLERANCES ON		
FRACTIONS ± 1/64	DECIMALS ± .015	ANGLES ± #
MATERIAL	SIGNATURE	DATE
CAST ALUMINUM	<i>R. Miller</i>	6-12-63
HEAT TREAT	<i>J. Kaufman</i>	6-13-63
FINISH	<i>J. D. Kelly</i>	6-14-63
	<i>C. C. C.</i>	6/14/63
	DSGN APPD	
	OTHER APPD	
AMP INFO		AMP INCORPORATED HARRISBURG, PENNSYLVANIA
LOC DF	PRINT DIST B30	M
SEE TABLE		TRADEMARK
		NAME
		SHIELD FOR ONE BLOCK MODULE ASSY. SERIES "G" ©
CODE IDENT NO	SIZE	NUMBER
00779	B	202305
SCALE 1-1	WT	CALC
	ACTUAL	SHEET 1 OF 1

NOTE:
 1. SHIELD TO ACCOMMODATE MODULE RECEPTACLE ASS'Y OR PLUG ASS'Y (1 BLOCK)

SP. M. 5001-41Z REV. 0