

Customer Information Sheet

DRAWING No.: H3151-XX

SHEET 2 OF 2

IF IN DOUBT - ASK

©

NOT TO SCALE

THIRD ANGLE PROJECTION

ALL DIMENSIONS IN mm

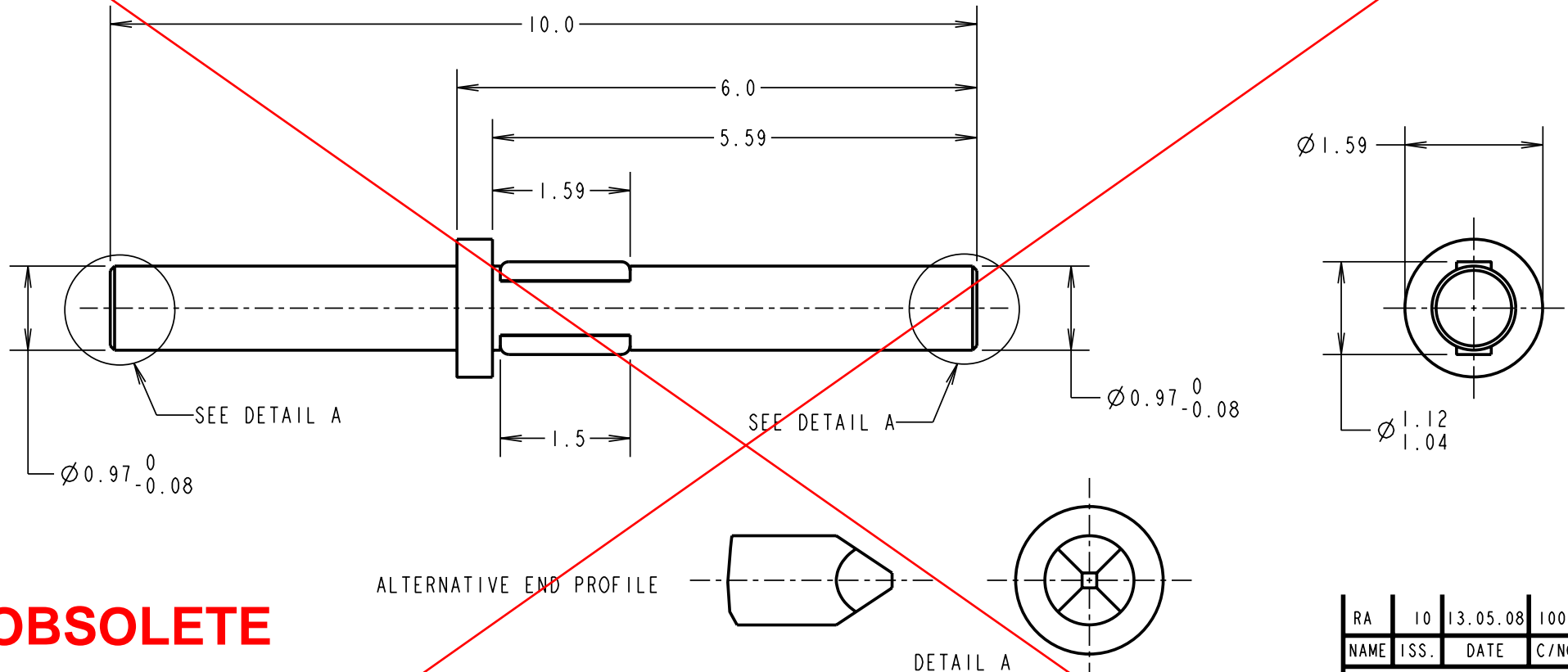

OBSOLETE

NOTES:

1. RECOMMENDED MOUNTING HOLE SIZE = $\varnothing 0.99-1.04$ mm.
2. RECOMMENDED PANEL THICKNESS = 1.6-2.4mm.
3. PUNCH & DIE TOOL PART No. = Z3151-00.

PART No.	FINISH
H3151-00	UNPLATED
H3151-01	7.6 μ 100% TIN

RA	10	13.05.08	10017
NAME	ISS.	DATE	C/NOTE
APPROVED:		R. ADDE	
CHECKED:		M.G. PLESTED	
DRAWN:		K. SHIER	
CUSTOMER REF.:			
ASSEMBLY DRG.:			

HARWIN

HARWIN USA
TEL: 603 893 5376
FAX: 603 893 5396
mis@harwin.com

HARWIN Europe (UK)
TEL: 023 9231 4545
FAX: 023 9231 4590
mis@harwin.co.uk

HARWIN Asia
TEL: +65 6 779 4909
FAX: +65 6 779 3868
mis@harwin.com.sg

THIS DRAWING AND ANY INFORMATION OR DESCRIPTIVE MATTER SET OUT HEREON ARE CONFIDENTIAL AND COPYRIGHT PROPERTY OF THE HARWIN GROUP AND MUST NOT BE DISCLOSED, LOANED, COPIED OR USED FOR MANUFACTURING, TENDERING OR FOR ANY OTHER PURPOSE WITHOUT THEIR WRITTEN PERMISSION.

TOLERANCES
X. = ± 1 mm
X.X = ± 0.25 mm
X.XX = ± 0.10 mm
X.XXX = ± 0.01 mm
ANGLES = $\pm 5^\circ$
UNLESS STATED

MATERIAL:
BRASS CW508L TO BS EN 1652 (CuZn37)

FINISH: SEE TABLE

S/AREA: mm²

TITLE:
COLD FORM
TERMINAL PIN

DRAWING NUMBER:
H3151-XX

SHT
2
OF 2