

DO NOT SCALE FROM THIS PRINT

- NOTES:
1. MIN CONTACT PUSHOUT: 1.5 LBS.
 2. FOR A 1 POSITION SINGLE ROW ALL SPACERS ARE TO BE TSW-XX-S.
 3. SPACERS SHALL BE ASSEMBLED AS SHOWN WITH SNAP GROOVES AWAY FROM SSW BODY.
 4. MAX ALLOWABLE BOW .003 INCH/INCH AFTER ASSMBLY
 5. DO NOT USE DSB SPACER BODY FOR THIS OPTION.
 6. MAX CUT FLASH : .010.

CONTACT STYLE
 SQUARE TAIL: USE C-15-X-X
 LOW INSERTION FORCE: C-60-X-X
 (SEE TABLE 1, SHT 2)

NO. OF POSITIONS
 POSITIONS 01 THRU 36
 (SEE FIG1)
 FOR A ONE POSITION SINGLE ROW SEE NOTE 2

LEAD STYLE
 (SEE TABLE 1, SHT 2)

PLATING SPECIFICATION
 -G: 20µ" GOLD IN CONTACT AREA, 3µ" GOLD TAIL
 -T: MATTE TIN CONTACT AND TAIL
 -S: 30µ" SELECTIVE GOLD IN CONTACT AREA, MATTE TIN TAIL
 -H: 30µ" HEAVY GOLD IN CONTACT AREA, 3µ" GOLD TAIL
 -L: 10µ" SELECTIVE LIGHT GOLD IN CONTACT AREA, MATTE TIN TAIL

ESQ-1XX-XX-X-X-XXX-XX-X-XX

***SEE NOTE 6**

METAL WASHER OPTION
 #* -H-MW: (SEE FIG 3, SHT 2)
 (N/A ON TRIPLE ROW)
 (.300 [7.62] MAX TAIL)
 (AVAILABLE ON POS -02 THRU -32 ONLY)

LOCKING LEAD OPTION
 -LL (SEE FIG 2, SHT 2)
 [N/A ON 1 OR 2 POSITION SINGLE ROW]

POLARIZATION OPTION
 INDICATES POSITION (SEE FIG 4, SHT 2)

ROW SPECIFICATION (SEE TABLE 1, SHT 2)
 -S: SINGLE (USE SSW-50-S)
 -D: DOUBLE (USE SSW-50-D)
 -T: TRIPLE (USE SSW-50-T)

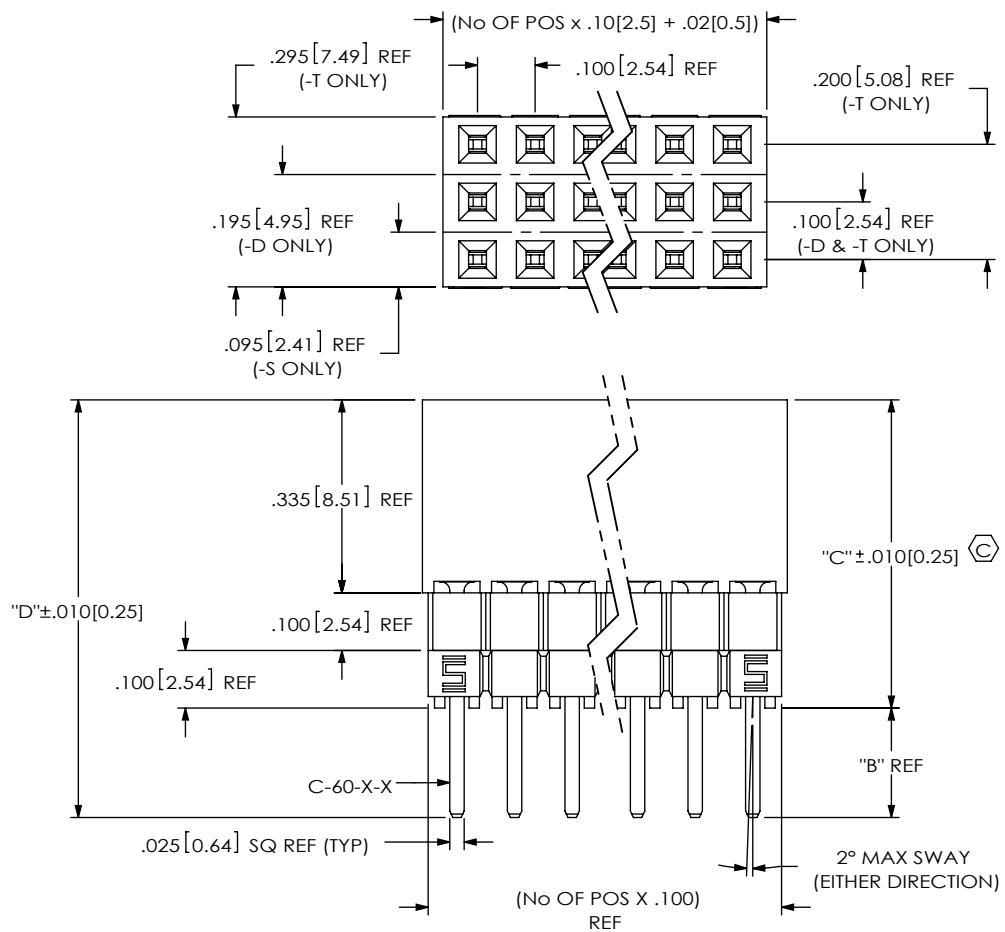

#-MW OPTION, DO NOT DESIGN IN. SAMTEC WILL ONLY SUPPORT EXISTING BUSINESS 2/12/02

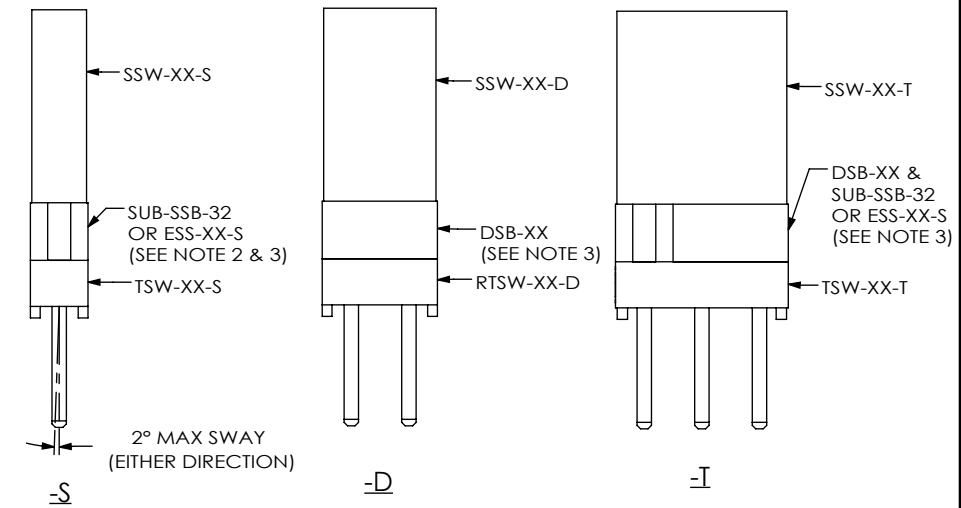
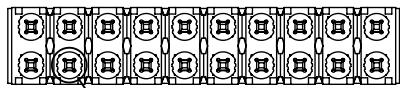

FIG 1
 ESQ-110-XX-X-T

UNLESS OTHERWISE SPECIFIED, DIMENSIONS ARE IN INCHES. TOLERANCES ARE: DECIMALS ANGLES .XX: ±.01 [0.3] .XXX: ±.005 [0.13] .XXXX: ±.0020 [0.051]	* PROPRIETARY NOTE THIS DOCUMENT CONTAINS CONFIDENTIAL AND PROPRIETARY INFORMATION AND ALL DESIGN, MANUFACTURING, REPRODUCTION, USE, PATENT RIGHTS AND SALES RIGHTS ARE EXPRESSLY RESERVED BY SAMTEC, INC. THIS DOCUMENT SHALL NOT BE DISCLOSED, IN WHOLE OR PART, TO ANY UNAUTHORIZED PERSON OR ENTITY NOR REPRODUCED, TRANSFERRED OR INCORPORATED IN ANY OTHER PROJECT IN ANY MANNER WITHOUT THE EXPRESS WRITTEN CONSENT OF SAMTEC, INC.	520 PARK EAST BLVD, NEW ALBANY, IN 47150 PHONE: 812-944-6733 FAX: 812-948-5047 e-Mail info@SAMTEC.com code 55322	
	MATERIAL: DO NOT SCALE DRAWING SHEET SCALE: 3:1 INSULATOR: LCP, UL 94 V0 COLOR: BLACK CONTACT : PHOS BRONZE		DESCRIPTION: ESQ STRIP ASM
	DWG. NO. ESQ-1XX-XX-X-X-XXX-XX-X-XX BY: JORDAN 7-16-85 SHEET 1 OF 4		



DETAIL A
SCALE 4 : 1

ESQ-110-XX-X-D-MW-T
.005 [0.13] MAX
MEASURE AT
THE TAIL

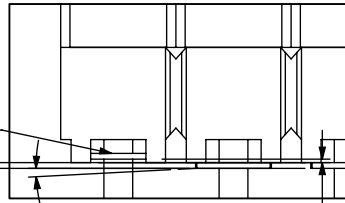

DETAIL B
SCALE 6 : 1

3° MAX SWAY
ANY DIRECTION

.003 [0.08] MAX
MEASURE AT
THE TAIL

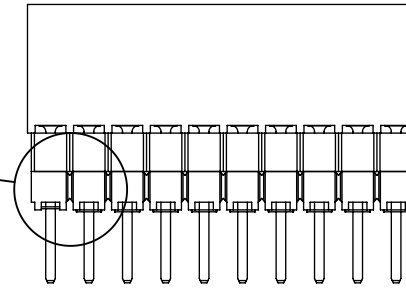
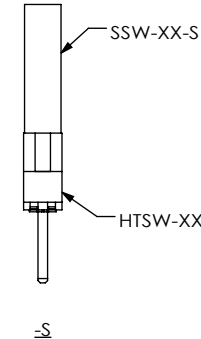

FIG 3

#-H-MW: METAL WASHER
ESQ-110-XX-X-X-MWT
(ONE PER POSITION)
(-S & -D BODY SPECS ONLY)
(SEE NOTE 5)

(SAME AS FIG 1 UNLESS OTHERWISE NOTED)



-S

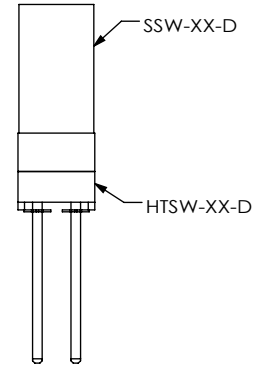

-D

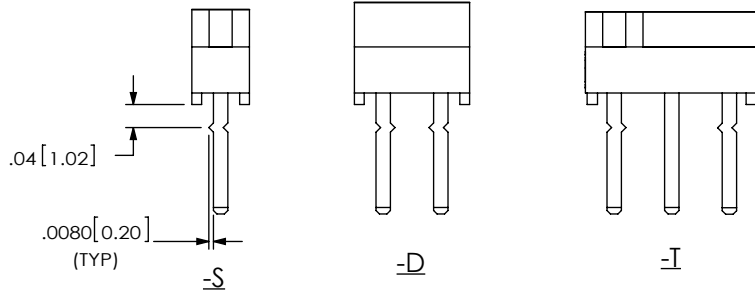
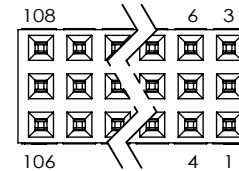
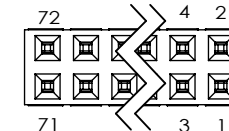

FIG 2

-LL: LOCKING LEAD OPTION
LOCATED ON OR ABOUT CENTERLINE
[N/A IN 1 OR 2 POSITION SINGLE ROW]



-I



-D

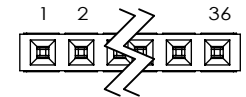

-S

FIG 4
XXX: POLARIZATION LOCATION
INSERT PK-06-N INTO SPECIFIED POS
AND BREAK OFF TAB

F:\DWG\MISC\MKTG\ESQ-1XX-XX-X-XXX-XX-X-MKT.SLDDRW

STANDARD INSERTION FORCE	CONTACT	SPACER SPECIFICATION (FOR A ONE POSITION SINGLE SEE NOTE 3)			"B"	"C"	"D"	"E"
		ESQ-S	ESQ-D	ESQ-T				
		-12	C-15-2-X	N/A				
-13	C-15-3-X	N/A	N/A	N/A	.29[7.37]	.435[11.05]	.725[18.41]	N/A
-14	C-15-4-X	N/A	N/A	N/A	.48[12.2]	.435[11.05]	.915[23.24]	N/A
-23	C-15-3-X	(1) SUB-SSB-32	(1) DSB-XX	(1) SUB-SSB-32 (1) DSB-XX	.19[4.83]	.535[13.59]	.725[18.41]	N/A
-24	C-15-4-X	(1) SUB-SSB-32	(1) DSB-XX	(1) SUB-SSB-32 (1) DSB-XX	.38[9.65]	.535[13.59]	.915[23.24]	N/A
-33	C-15-3-X	(2) SUB-SSB-32	(2) DSB-XX	(2) SUB-SSB-32 (2) DSB-XX	.09[2.87]	.635[16.13]	.725[18.41]	N/A
-34	C-15-4-X	(2) SUB-SSB-32	(2) DSB-XX	(2) SUB-SSB-32 (2) DSB-XX	.28[7.11]	.635[16.13]	.915[23.24]	N/A
-44	C-15-4-X	(1) ESS-XX-S	(3) DSB-XX	(1) ESS-XX-S (3) DSB-XX	.18[4.57]	.735[18.67]	.915[23.24]	N/A
LOW INSERTION FORCE	CONTACT	SPACER SPECIFICATION (FOR A ONE POSITION SINGLE SEE NOTE 3)			"B"	"C"	"D"	"E"
		ESQ-S	ESQ-D	ESQ-T				
		-37	C-60-2-X	N/A				
-38	C-60-3-X	N/A	N/A	N/A	.29[7.37]	.435[11.05]	.725[18.41]	N/A
-39	C-60-4-X	N/A	N/A	N/A	.48[12.2]	.435[11.05]	.915[23.24]	N/A
-48	C-60-3-X	SUB-SSB-32	(1) DSB-XX	(1) SUB-SSB-32 (1) DSB-XX	.19[4.83]	.535[13.59]	.725[18.41]	N/A
-49	C-60-4-X	(1) SUB-SSB-32	(1) DSB-XX	(1) SUB-SSB-32 (1) DSB-XX	.38[9.65]	.535[13.59]	.915[23.24]	N/A
-58	C-60-3-X	(2) SUB-SSB-32	(2) DSB-XX	(2) SUB-SSB-32 (2) DSB-XX	.09[2.87]	.635[16.13]	.725[18.41]	N/A
-59	C-60-4-X	(2) SUB-SSB-32	(2) DSB-XX	(2) SUB-SSB-32 (2) DSB-XX	.28[7.11]	.635[16.13]	.915[23.24]	N/A
-69	C-60-4-X	(1) ESS-XX-S	(3) DSB-XX	(1) ESS-XX-S (3) DSB-XX	.18[4.57]	.735[18.67]	.915[23.24]	N/A

PROPRIETARY NOTE
THIS DOCUMENT CONTAINS CONFIDENTIAL AND PROPRIETARY INFORMATION AND ALL DESIGN, MANUFACTURING, REPRODUCTION, USE, PATENT RIGHTS AND SALES RIGHTS ARE EXPRESSLY RESERVED BY SAMTEC, INC. THIS DOCUMENT SHALL NOT BE DISCLOSED, IN WHOLE OR PART, TO ANY UNAUTHORIZED PERSON OR ENTITY NOR REPRODUCED, TRANSFERRED OR INCORPORATED IN ANY OTHER PROJECT IN ANY MANNER WITHOUT THE EXPRESS WRITTEN CONSENT OF SAMTEC, INC.

DO NOT SCALE DRAWING

SHEET SCALE: 1:1



520 PARK EAST BLVD, NEW ALBANY, IN 47150
PHONE: 812-944-6733 FAX: 812-948-5047
e-Mail: info@SAMTEC.com code 55322

DESCRIPTION: ESQ STRIP ASM

DWG. NO. ESQ-1XX-XX-X-X-XXX-XX-X-XX

BY: WHITTAKER 9-11-98 SHEET 2 OF 4

LOAD CONTACT

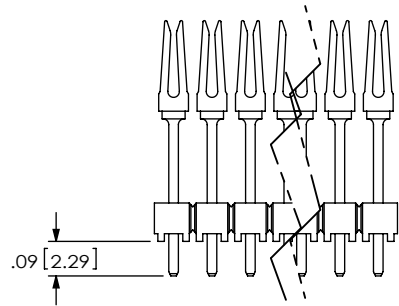

PRESS ON -MW

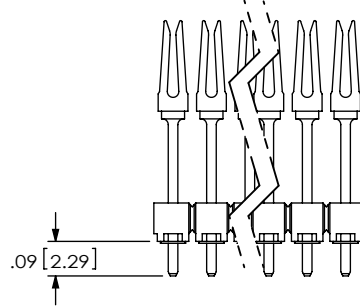

PRESS ON SSW BODY

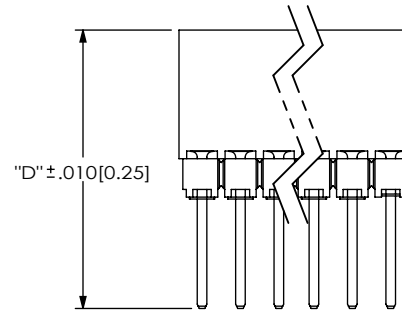

IN PROCESS
-12, -33, -37, -58

LOAD CONTACT

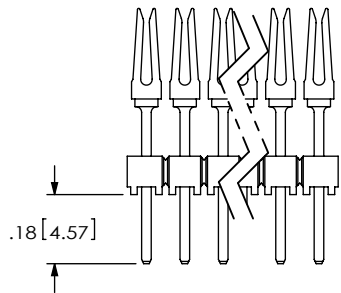

PRESS ON -MW

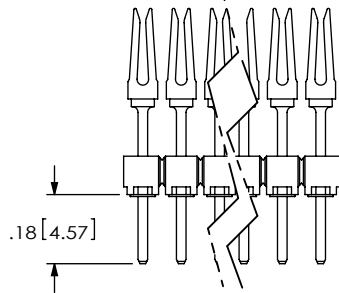

PRESS ON SSW BODY

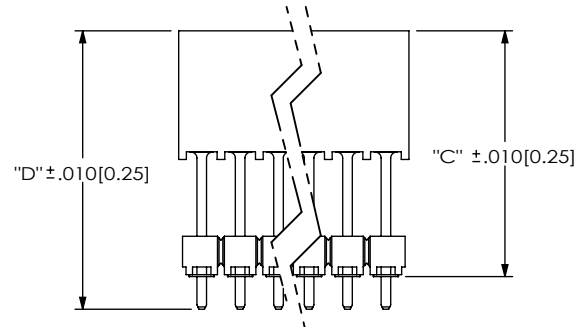

REPRESS STACKER BODY AND -MW TO PROPER "C" DIM

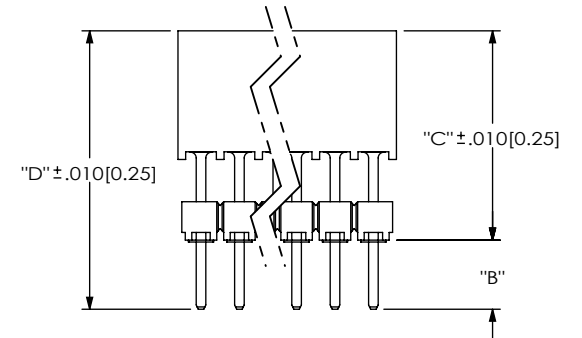

IN PROCESS
-13, -14, -23, -24, -34, -38
-39, -44, -48, -49, -59, -69

PROPRIETARY NOTE

THIS DOCUMENT CONTAINS CONFIDENTIAL AND PROPRIETARY INFORMATION AND ALL DESIGN, MANUFACTURING, REPRODUCTION, USE, PATENT RIGHTS AND SALES RIGHTS ARE EXPRESSLY RESERVED BY SAMTEC, INC. THIS DOCUMENT SHALL NOT BE DISCLOSED, IN WHOLE OR PART, TO ANY UNAUTHORIZED PERSON OR ENTITY NOR REPRODUCED, TRANSFERRED OR INCORPORATED IN ANY OTHER PROJECT IN ANY MANNER WITHOUT THE EXPRESS WRITTEN CONSENT OF SAMTEC, INC.

DO NOT SCALE DRAWING

SHEET SCALE: 1:1



520 PARK EAST BLVD, NEW ALBANY, IN 47150
PHONE: 812-944-6733 FAX: 812-948-5047
e-Mail info@SAMTEC.com code 55322

DESCRIPTION: ESQ STRIP ASM

DWG. NO. ESQ-1XX-XX-X-X-XXX-XX-X-XX

BY: WITHTKAKER 9-11-98

SHEET 3 OF 4

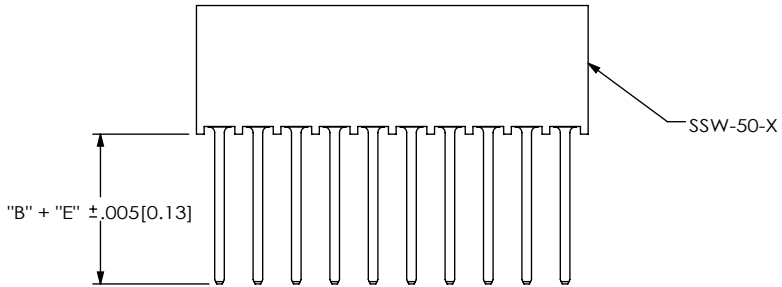

STEP 1
MACHINE FILL SSW-50-X

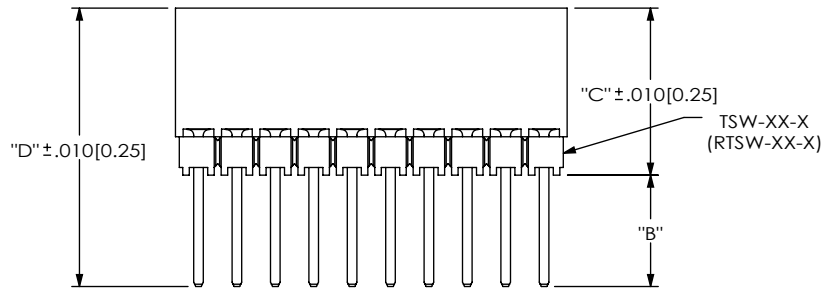

STEP 2
MULTI-CUT TSW-50-X TO POS (RTSW-50-D FOR DOUBLE ROW AND MOUNT AS SHOWN. (IF RTSW-50-D NOT AVAILABLE, TSW-50-D MAY BE USED)

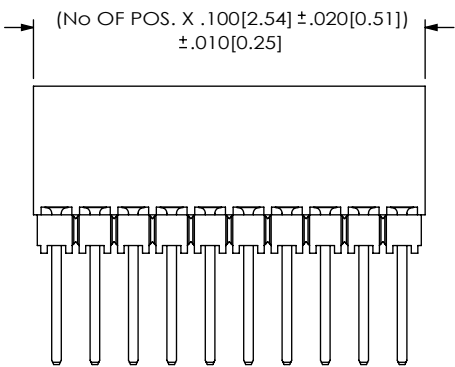

STEP 3
ROTO CUT TO POS

FIG 5
ESQ-110-XX-X-S
IN PROCESS "B"
(LEAD STYLE -12 & -37)
(-S & -D ONLY)

TABLE 2			
LEAD STYLE	ROW	TUBE	PLUG (2)
-12, -37	-S	PT-1-24-01-46	TP-24
-13, -14, -23, -24, -33, -34, -44, -38, -39, -48, -49, -58, -59, -69		PT-1-24-01-47	TP-24
-12, -37	-D	PT-1-24-03-44	TP-07
-14, -24, -34, -44, -39, -49, -59, -69		PT-1-24-02-47	TP-07
-13, -23, -33, -38, -48, -58		PT-1-24-01-51	TP-13
-12, -37	-T	PT-1-24-01-51	TP-13
-13, -14, -23, -24, -33, -34, -44, -38, -39, -48, -49, -58, -59, -69		PT-1-24-03-51	TP-13

1. FOR -12 & -37 LEAD STYLES TUBE PAC KAGE -04 THRU -36 POSITION ONLY.
2. FOR -13, -23, -33, -38, -48, & -58 LEAD STYLES TUBE PACKAGE -08 THRU -36 POSITIONS ONLY.
3. FOR -14, -24, -34, -44, -39, -49, -59, & -69 LEAD STYLES -05 THRU -36 POSITIONS ONLY.

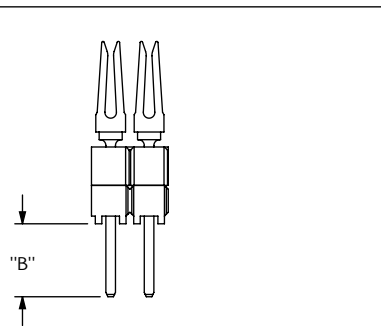
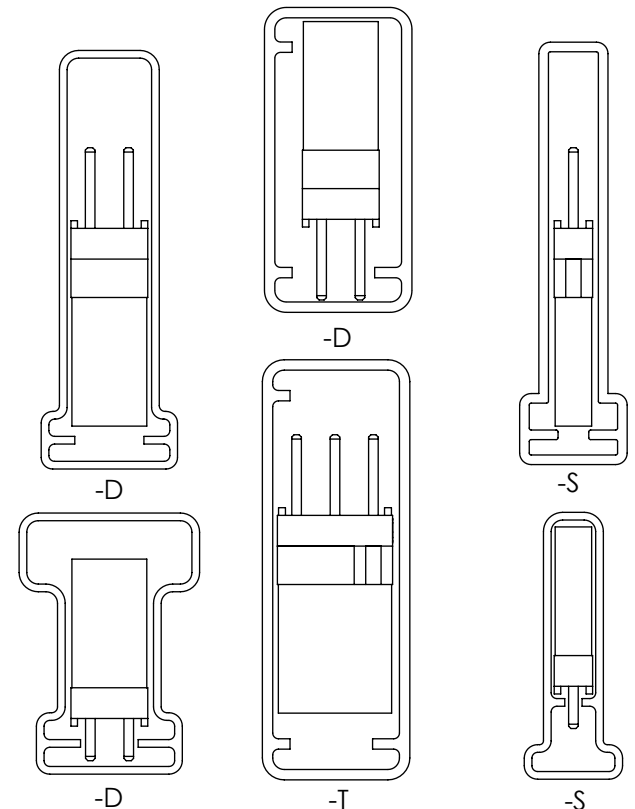

FIG 6
ESQ-110-XX-X-D
IN PROCESS "A"
(LEAD STYLE -12-T, -13, -14, -23, -24, -33, -34, -44, -37-T, -38, -48, -49, -58, -59, -69)



PROPRIETARY NOTE
THIS DOCUMENT CONTAINS CONFIDENTIAL AND PROPRIETARY INFORMATION AND ALL DESIGN, MANUFACTURING, REPRODUCTION, USE, PATENT RIGHTS AND SALES RIGHTS ARE EXPRESSLY RESERVED BY SAMTEC, INC. THIS DOCUMENT SHALL NOT BE DISCLOSED, IN WHOLE OR PART, TO ANY UNAUTHORIZED PERSON OR ENTITY NOR REPRODUCED, TRANSFERRED OR INCORPORATED IN ANY OTHER PROJECT IN ANY MANNER WITHOUT THE EXPRESS WRITTEN CONSENT OF SAMTEC, INC.

DO NOT SCALE DRAWING

SHEET SCALE: 1:1

samtec
520 PARK EAST BLVD, NEW ALBANY, IN 47150
PHONE: 812-944-6733 FAX: 812-948-5047
e-Mail info@SAMTEC.com code 55322

DESCRIPTION: ESQ STRIP ASM

DWG. NO. ESQ-1XX-XX-X-X-XXX-XX-X-XX

BY: WHITTAKER 9-11-98 SHEET 4 OF 4