

1

2

3

4

NOTES:

- 1-Material:phosphor bronze,thickness 0.20
- 2-Finish on contact area:see table
finish on termination:bright tin over nickel
- 3-Wire range:24 to 28 AWG
- 4-Max outer dia of wire insulator:1.02 mm
- 5-Current carrying capacity per contact:
 - 3.Amps max when crimped to #24 AWG
 - 2 Amps max when crimped to #26 AWG
 - 1 Amps max when crimped to #28 AWG
- 6-After 5 insertions into connector,
contact retention must be 5 pounds axial load min
- 7-When contact is crimped to 24 AWG,the insulation
support crimped height must be 1.78 mm max to ensure
a proper insertion into housing
- 8-Reel should be continuous without any contacts
missing in between
- 9-Packaging:Reel of 400 contacts

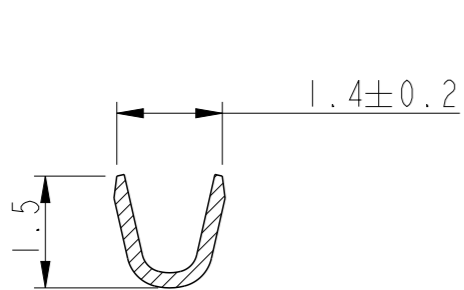
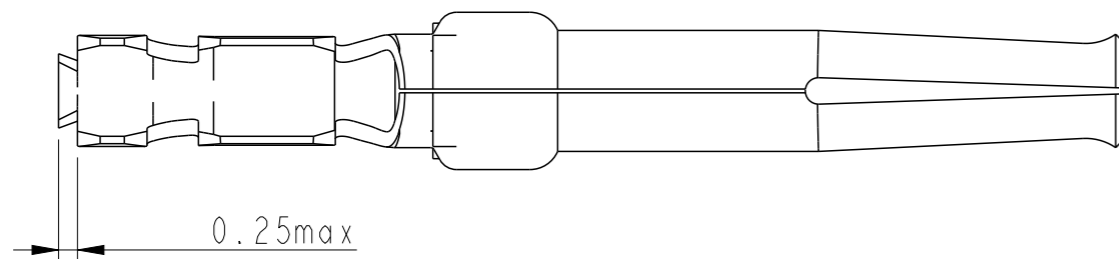
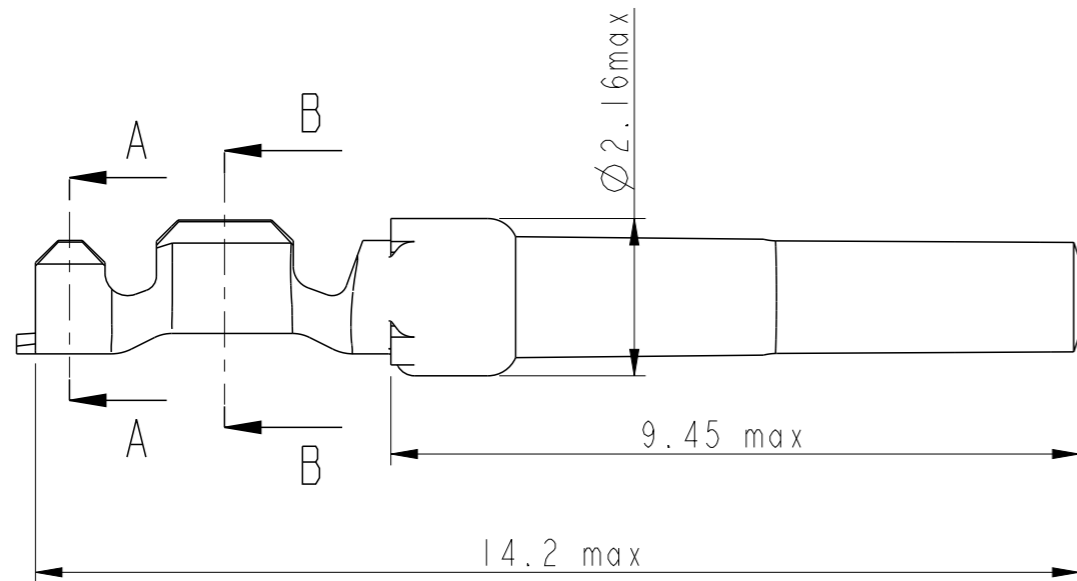
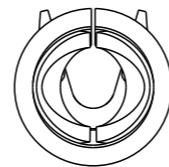

SECTION A-A

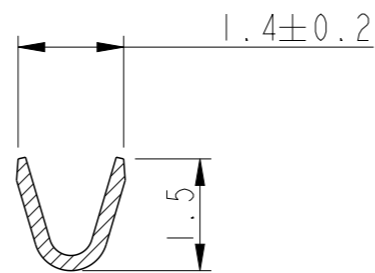

SECTION B-B

NOTE : ROHS INFORMATIONS

The LF products meet European union directives and other country regulations as described in GS-22-008
Terminations plating spec : 2um Nickel min + 2um Sn min
Packaging Spec : see GS-14-920

PART NUMBER	PLATING
86563004065LF	0.76μ Au /GXT
86563004065	0.76μ Au/ GXT
86563004064LF	Flash Au
86563004064	Flash Au

www.fciconnect.com		surface - ✓ ISO 1302	tolerance std ISO 406 ISO 1101	projection mm
TOLERANCES UNLESS OTHERWISE SPECIFIED				
Dr	C JARRY	28/01/97	ANGULAR	0.X ±0.3
Eng			LINEAR	0.XX ±0.1
Chr			0° ±2°	0.XXX ±0.05
Appr			Product family	size A3 ECN 111-0003
FCi CRIMP SOCKET				Spec ref
#Wire 24-28 Ø1.02 max				Rev. J
catalog no				dwg no C01-8656-0426
				customer sheet 1 of 1

rev	ecn no	dr	date
D	LS06-196	MPE	27/11/2006
E	LS08-0127	MPE	13/05/2008
F	LS08-0167	MPE	2008/08/05
G	109-0152	AMR	2009-07-27
H	110-0070	AMR	2010-03-09
J	111-0003	AMR	2011-01-06
-	-	-	-

1

2

3



Copyright FCI.