

Attachment: Unified screw thread 0-80UNF 3/16inch

MARKING POSITION

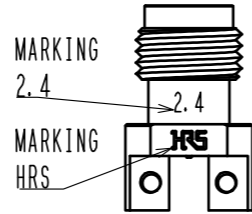

- NOTES
- 1 WHEN MATING THE CONNECTOR, PLEASE HOLD MILLING AREA OF 6.4 ± 0.2 WITH A WRENCH.
 - 2 0-80UNF-2B SCREW TIGHTENING TORQUE IS $0.09 \text{ N} \cdot \text{m}$. PLEASE TIGHTEN THE SCREWS EVENLY WHEN MOUNTING THE CONNECTORS TO ENSURE STABLE ELECTRICAL CONTACT.
 - 3 PLEASE USE A PCB MOUNTING SCREW OF THE LENGTH OF L(mm). THE LENGTH OF L(mm) IS PCB THICKNESS $t_1(\text{mm})$ + SPRING WASHER THICKNESS $t_2(\text{mm})$ + $1.8(\text{mm})$. PLEASE USE A SCREW WITH SPRING WASHER.
 - 4 THE INDICATED DIMENSION IS THE CASE OF WHICH DIELECTRIC CONSTANT OF SUBSTRATE IS 3.35 AND THICKNESS IS $t=0.2\text{mm}$. LAND PATTERN LAYOUT DEPENDS ALSO ON ELECTRIC CONSTANT, THICKNESS AND LAYER CONSTRUCTION OF PCB. FOR BETTER PERFORMANCE, SIMULATION OF PCB WITH CONNECTOR IS RECOMMENDED.
 - 5 RECOMMENDED PCB THICKNESS t_1 IS GREATER THAN 1.0mm .
 - 6 SIDE PLATING OF THE BOARD IS RECOMMENDED.
 7. THIS CONNECTOR SHOULD BE USE FOR TEST PORT ONLY.

MOUNTING OF CONNECTOR

- (1) WHEN THE CONNECTOR IS MOUNTED ON PCB, PLEASE DO NOT ALLOW A GAP BETWEEN THE EDGE OF PCB AND CONNECTOR.
- (2) PLEASE MOUNT THE CONNECTOR AS LOCATED IN THE MIDDLE OF THE SIGNAL PAD OF PCB.
- (3) SOLDERING CONDITIONS:(OPTIONAL:IT'S POSSIBLE TO USE WITHOUT SOLDERING) FOR THE MANUAL SOLDERING, SOLDERING IRON BIT TEMPERATURE IS 380°C MAX. FOR 5 SECONDS MAX.

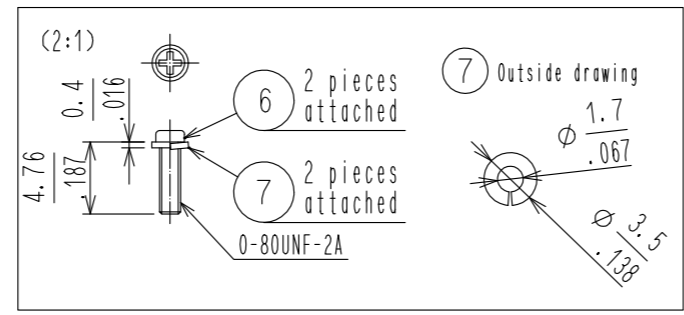
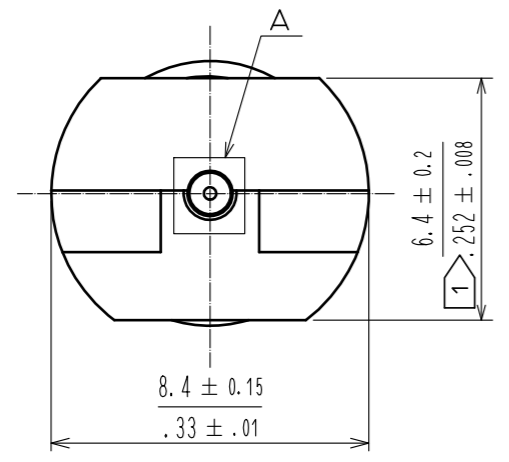
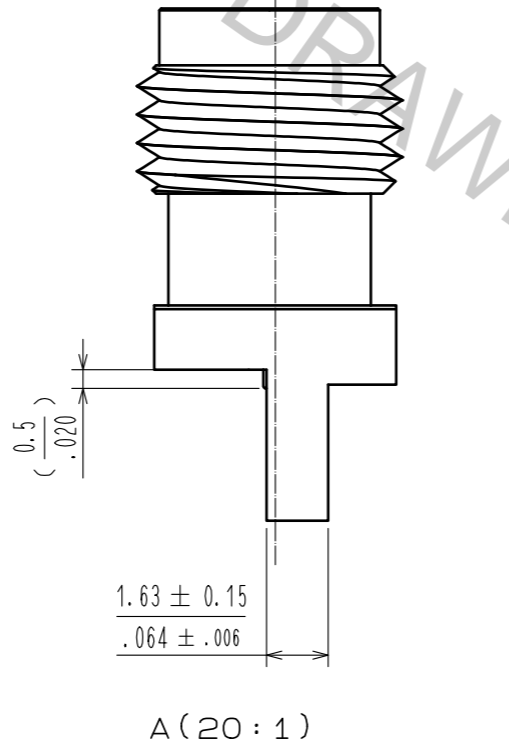
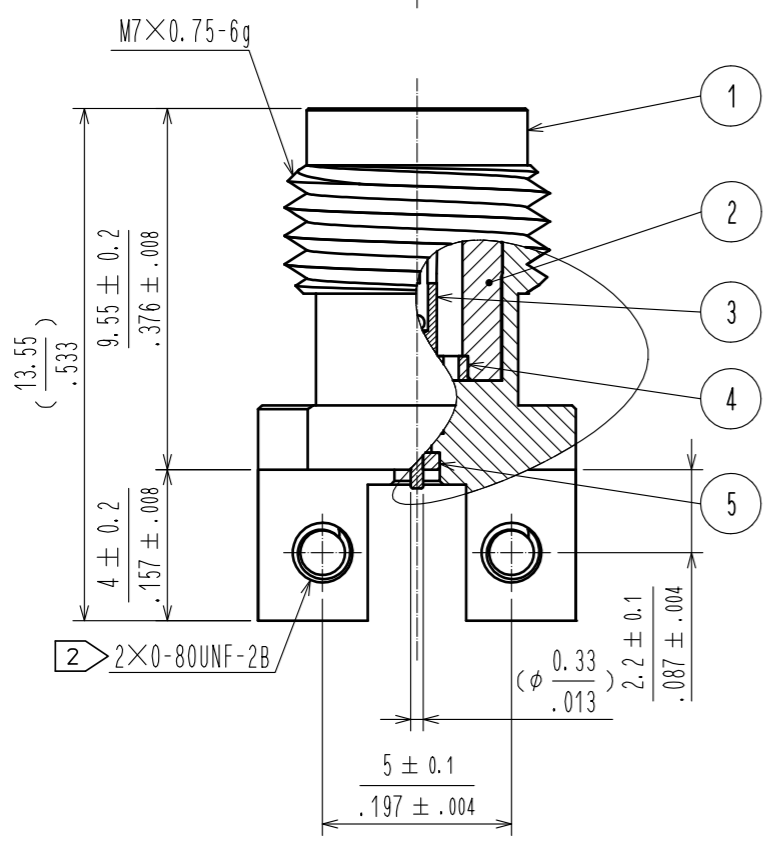
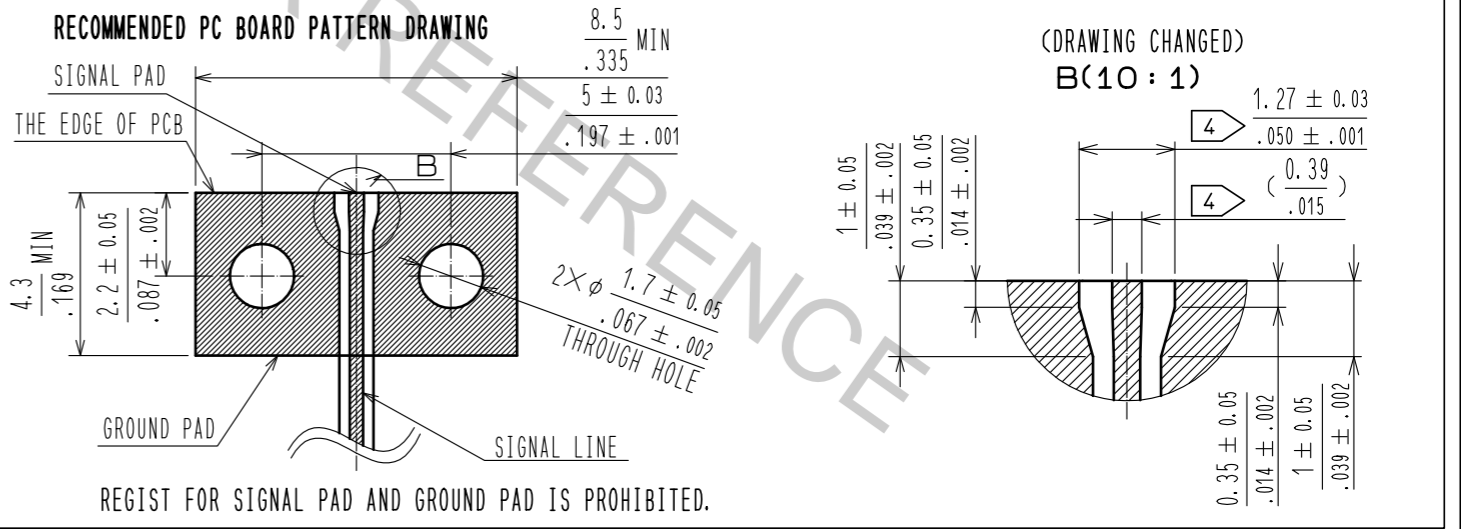
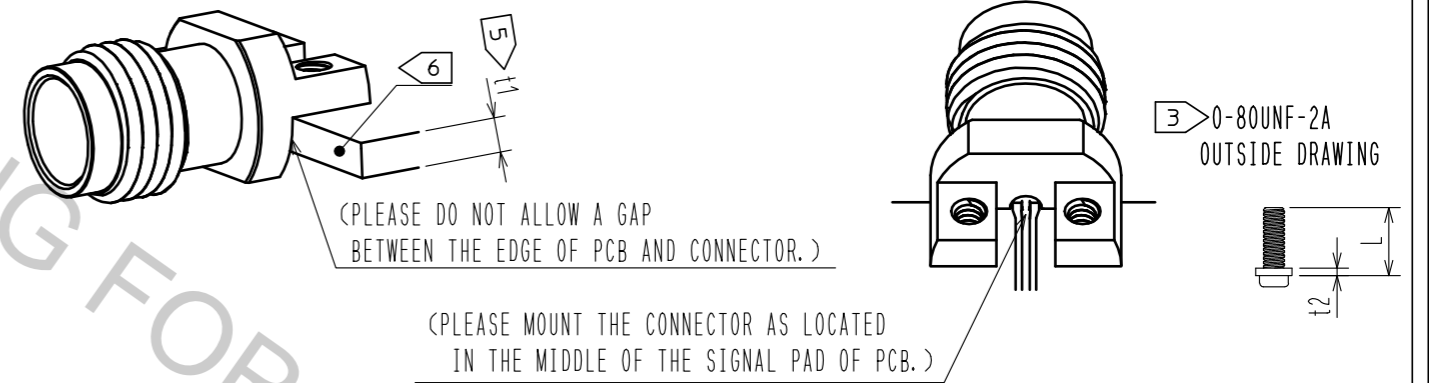

3	BERYLLIUM COPPER	GOLD PLATING	7	STAINLESS STEEL	Spring washer
2	STAINLESS STEEL	PASSIVATE	6	STEEL	0-80UNF-2A Screw
1	BRASS	NICKEL PLATING	5	POLYETHER IMIDE	
			4	POLYETHER IMIDE	
NO.	MATERIAL	FINISH . REMARKS	NO.	MATERIAL	FINISH . REMARKS
UNITS [mm/in]		SCALE 5:1	COUNT 1	DESCRIPTION OF REVISIONS DIS-D-00003223	DESIGNED DS. YAMAKOSHI
					CHECKED NK. NINOMIYA
					DATE 18.06.19
					APPROVED : KH. IKEDA 17.01.23
					CHECKED : TS. NOBE 17.01.20
					DESIGNED : TP. MATSUMOTO 17.01.20
					DRAWN : TP. MATSUMOTO 17.01.20
					DRAWING NO. EDC-368795-12-01
					PART NO. H2.4-LR-SR2(12)
					CODE NO. CL338-0603-0-12

Aug.1.2018 Copyright 2018 HIROSE ELECTRIC CO., LTD. All Rights Reserved. In case that the application demands a high level of reliability, such as automotive, please contact a company representative for further information.