

DRAWING MADE IN THIRD ANGLE PROJECTION

© COPYRIGHT 1978 BY AMP INCORPORATED, HARRISBURG, PA. ALL INTERNATIONAL RIGHTS RESERVED. AMP INCORPORATED PRODUCTS COVERED BY U. S. AND FOREIGN PATENTS AND/OR PATENTS PENDING.

PART NO.	COLOR	PIN FINISH	
858082-1	BLACK	TIN PLATED	
858082-2	BLACK	GOLD PLATED	OBS.

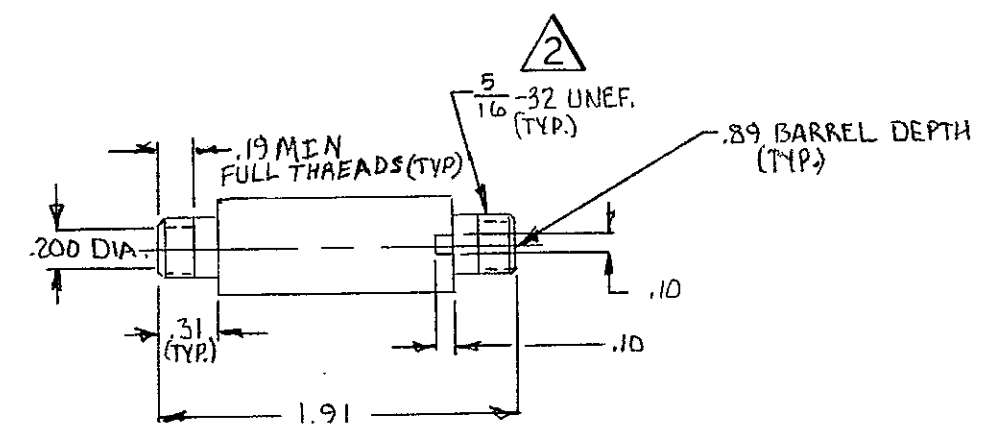
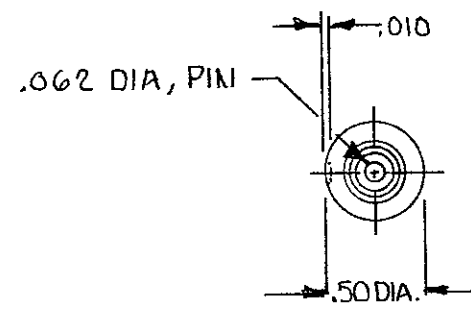

REVISIONS						
P	F	ZONE	LTR	DESCRIPTION	DATE	APPROVED
			E	REV. REDRAWN	RN 4/19/78	YM-P
			F	REV PER ECN 5-3960	4/20/87	RS
			G	OBS. -2 PER ECN DFO694	me 9-26-88	T.W.
			H	REV PER 0600-7844-98	JB 1-5-99	M.L.

1. RECEPTACLE TO MATE WITH AMP LGH-1/2L LEAD ASSEMBLY, AVAILABLE SEPARATELY.
 2. PER FEDERAL STANDARD H-28 3 WIRE METHOD. DIMENSION OVER WIRES TO BE: .307-.318.

				UNLESS OTHERWISE SPECIFIED DIMENSIONS ARE IN INCHES. TOLERANCES: .00 ±.03 .000 ±.015 ANGLES ±		CONTRACT NO		AMP INCORPORATED Elizabethtown, Pa.	
				MATERIAL MOLDED GLASS EPOXY		DR 4-7-78		NAME LGH-1/2L RECEPTACLE, FEED-THRU FOR SPLICE APPLICATIONS	
				FINISH		CHK		LGH	
						APPD		SIZE CODE IDENT NO DRAWING NO	
						APPD		C 00779 858082	
						DSGN APPD		SCALE	
						OTHER APPD		SHEET	
NEXT ASSY	FINAL ASSY	NEXT ASSY	USED ON						
QTY REQD		APPLICATION							