

Apr.1.2017 Copyright 2017 HIROSE ELECTRIC CO., LTD. All Rights Reserved.

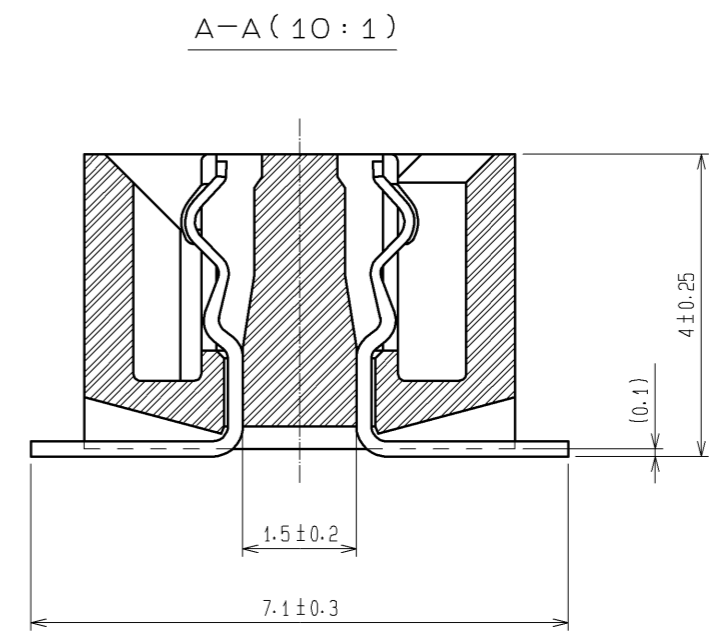

RECOMMENDED LAND PATTERN DIMENSION OF PCB (MOUNTING SIDE)  
(METAL MASK THICKNESS: t=0.15)

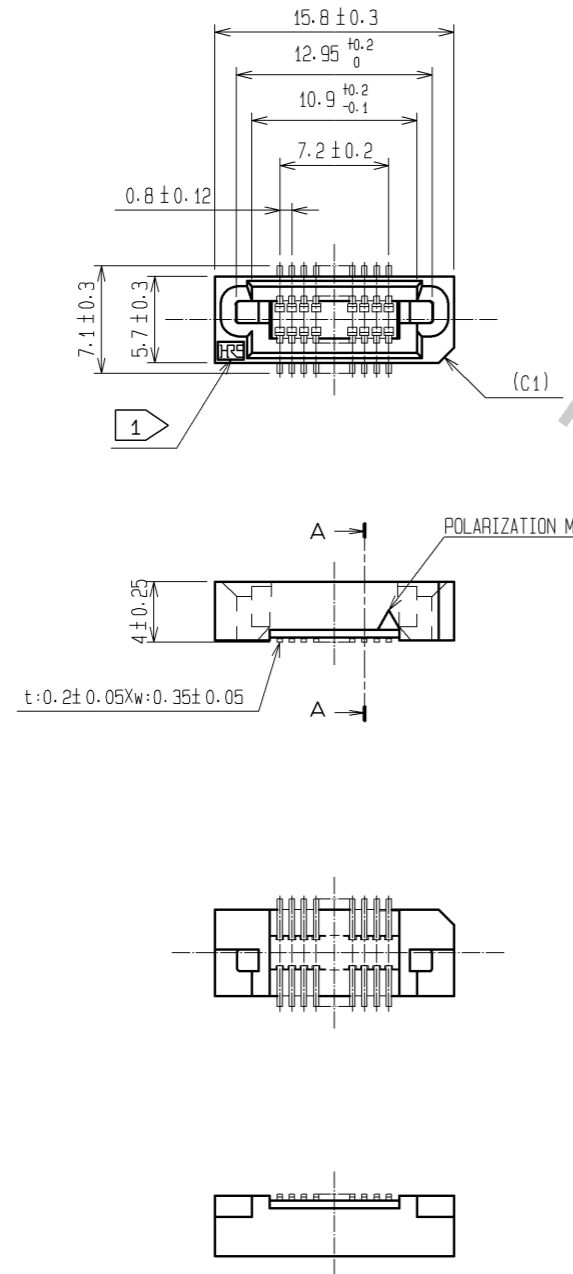
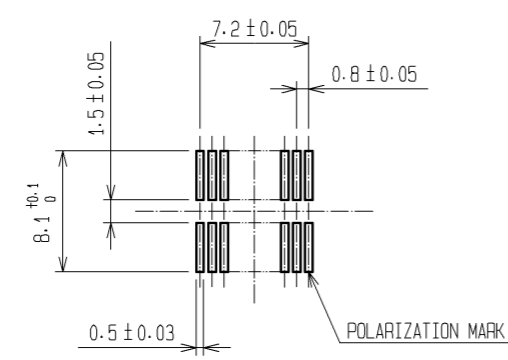

- NOTE
- 1 HRS MARK SHALL BE OPTIONAL.
  - 2 LEAD CO-PLANARITY SHALL BE 0.1mm MAX.
  - 3 FOR MODIFICATION, ETC., PREVENTIVE HOLE FOR SINK MARK MAY BE ADDED ACCORDING TO CIRCUMSTANCES.
  - 4 THE DIMENSIONS IN PARENTHESES ARE FOR REFERENCE.

1	PPS	LIGHT BROWN (UL94V-0)	2	PHOSPHOR BRONZE	CONTACT AREA: GOLD 0.1µm min. LEAD AREA: TIN-PLATING 1µm min. UNDER PLATING: NICKEL 2µm min.		
NO.	MATERIAL	FINISH . REMARKS	NO.	MATERIAL	FINISH . REMARKS		
UNITS mm		SCALE 2 : 1	COUNT △	DESCRIPTION OF REVISIONS	DESIGNED	CHECKED	DATE
<b>HRS</b> HIROSE ELECTRIC CO., LTD.		APPROVED : HS. OKAWA	08.06.23	DRAWING NO.	EDC3-071317-25		
		CHECED : HT. YAMAGUCHI	08.06.20	PART NO.	FX6A-20S-0.8SV(71)		
		DESIGNED : KN. SHIBUYA	08.06.20	CODE NO.	CL576-0301-7-71		
		DRAWN : TH. SANO	08.06.19		△ 1/1		