

RAA207703GBM/7704GBM/7705GBM

Synchronous Buck Regulator with Internal Power MOSFETs

R07DS0892EJ0100
Rev.1.00
Aug 02, 2013

Description

The RAA207703GBM is monolithic synchronous buck regulator with power MOSFETs in extremely small package. The RAA207703GBM delivers high output current by small $R_{ds(on)}$ Power MOSFETs. Constant on time control architecture provides fast transient response, and minimize external components. The RAA207703GBM operates skip mode at light load, it provides high efficiency in all load condition. The RAA207703GBM incorporates internal 5V LDO, so the regulator can operate single power supply. Three current ability products can be selected.

Features

- Input voltage range: 5.5 V to 16 V (internal LDO use), 3.0 V to 16 V (external 5 V use)
- Output voltage range: 0.8 V to 5.0 V
- Constant-On-Time control
- Built-in power MOSFETs suitable for PC, Server application
- Internal 5 V LDO for single power supply operation
- 5 V LDO / external 5 V input selectable (LDO remote ON/OFF)
- Switching frequency: Adjustable up to 2 MHz
- High average output current, up to 15 A (7703GBM), 10 A (7704GBM), 5 A (7705GBM)
- Controllable driver: Remote ON/OFF
- Power Good function
- Over current protection/Over voltage protection/Thermal shutdown function
- Built-in bootstrapping diode
- Soft Start period adjustable
- Enhanced light load mode function for higher efficiency
- Extremely small chip size package with solder bump
- Pb-Free/Halogen-Free

Application Circuit

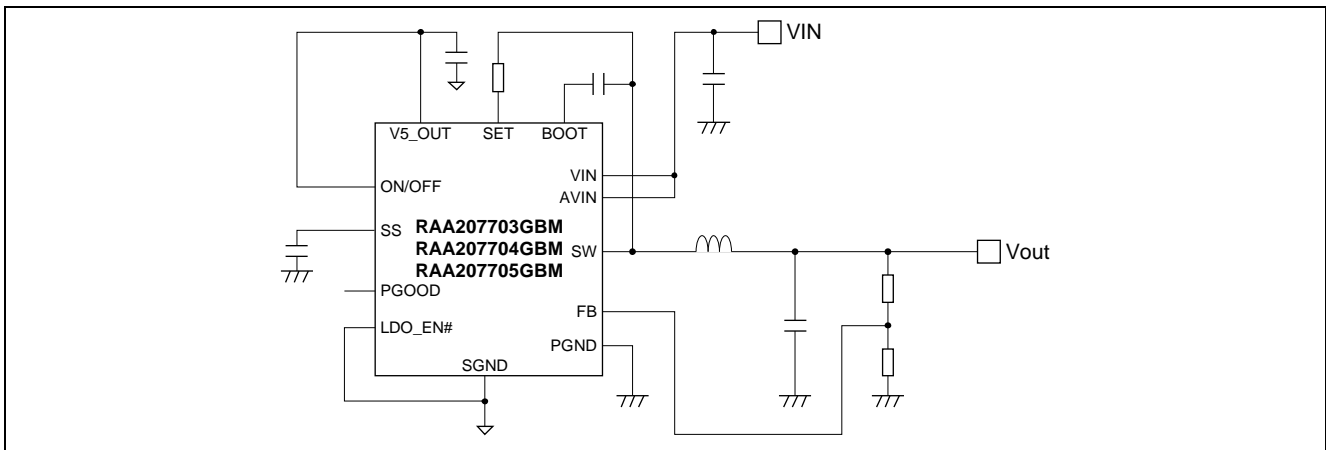

Pin Arrangement



Pin Description

Pin Name	Pin No.	Description	Remarks
V5_OUT	1A	Controller voltage	Controller supply (5 V regulator output)
SGND	2A	Controller analog GND	Should be connected to PGND on PCB pattern
FB	3A	Feedback voltage input pin	
LDO_EN#	4A	Internal 5 V LDO enable pin	
AVIN	5A	Analog input voltage	Should be connected to VIN on PCB pattern
BOOT	1B	Bootstrap voltage pin	To be supplied +5 V through integrated SBD
SET	2B	Constant on time program pin	Tie resistor between SW and SET pin
PGOOD	3B	Power good indicator pin	Pull low when No Good (open drain output)
SS	4B	Soft start period program pin	Tie capacitor between SS and SGND
ON/OFF	5B	Operation enable pin	Operation stop when "L" signal asserted
VIN	—	Input voltage	
SW	—	Switching node	
PGND	—	Power GND	Should be connected to SGND on PCB pattern

Note: Pin assign of 1A-5A & 1B-5B is common through RAA207703GBM, RAA207704GBM and RAA207705GBM.

Block Diagram

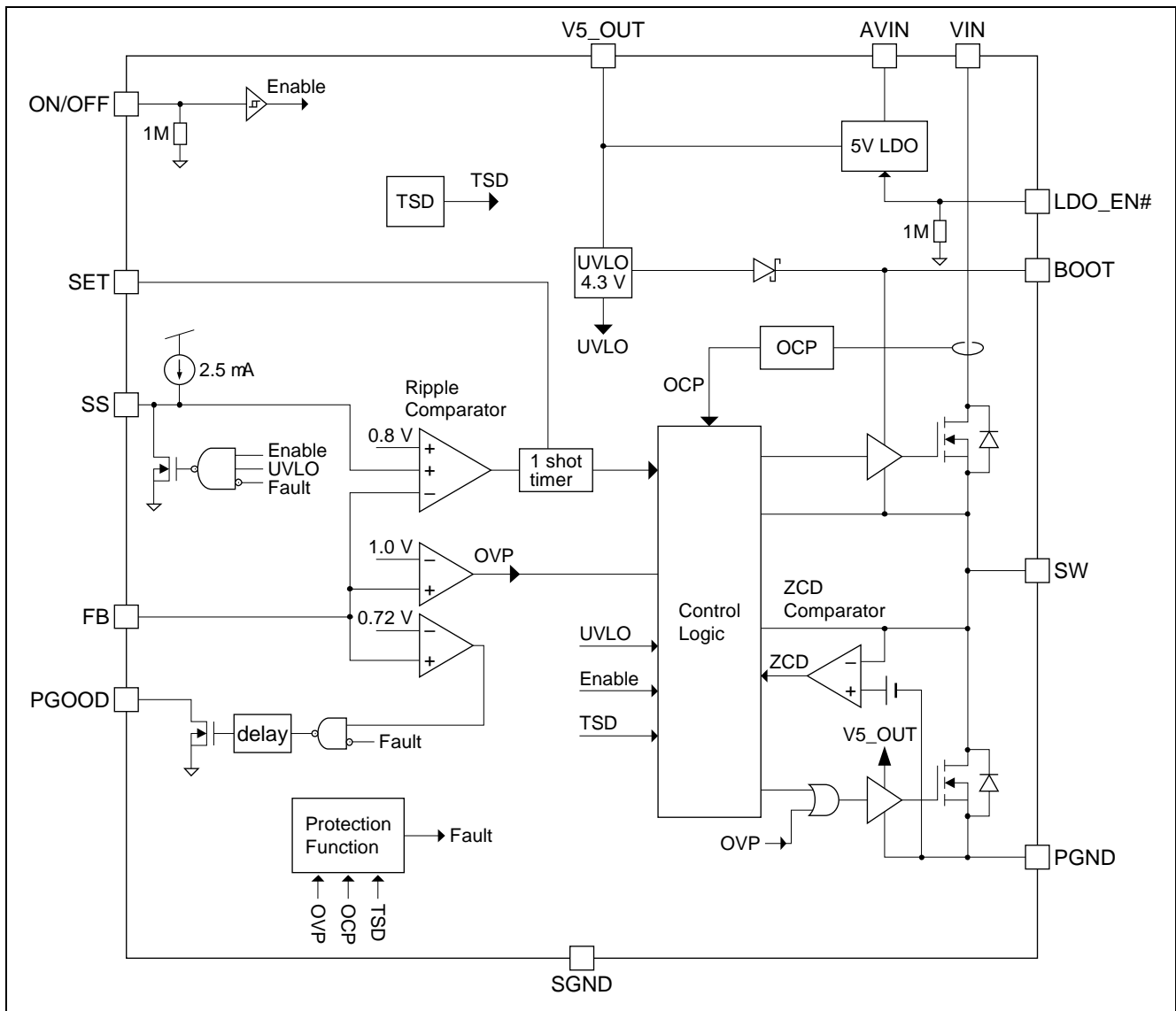

1. Truth table for the ON/OFF pin

ON/OFF Input	Driver Chip Status
"L"	Shutdown (operation STOP)
"Open"	Shutdown (operation STOP)
"H"	Enable (Normal operation)

2. Truth table for LDO_EN# pin

LDO_EN# Input	5 V Regulator Status
"L"	LDO enable
"Open"	LDO enable
"H"	LDO disable

Absolute Maximum Ratings

(Ta = 25°C)

Item	Symbol	Ratings	Unit	Notes
Input voltage	VIN, AVIN	-0.3 to +20	V	1
Switch node voltage	SW	20(DC), 23(<10 ns)	V	1
BOOT voltage	VBOOT	25(DC), 28(<10 ns)	V	1, 2
Controller voltage	V5_OUT	-0.3 to +6	V	1
V5_OUT current	ICC	-20 to +0.1	mA	3
FB pin voltage	VFB	-0.3 to V5_OUT +0.3	V	1, 4
ON/OFF voltage	VON/OFF	-0.3 to VIN	V	1
LDO_EN# voltage	VLDO_EN#	-0.3 to VIN	V	1
SET voltage	VSET	-0.3 to VIN	V	1
PGOOD voltage	VPGOOD	-0.3 to VIN	V	1
PGOOD sink current	IPGOOD	+2	mA	3
Operating junction temperature	Tj-opr	-40 to +125	°C	
Storage temperature	Tstg	-55 to +150	°C	

- Notes: 1. Rated voltages are relative to voltages on the SGND and PGND pins.
 2. BOOT – V5_OUT < 20 V
 3. For rated current, (+) indicates inflow to the chip and (-) indicates outflow.
 4. V5_OUT + 0.3 V < 6 V

Thermal Information

Item	Symbol	Part No.	Value	Unit	Note
Thermal resistance (junction to air when device is mounted on evaluation board)	qj-a	RAA207703GBM	27	°C/W	1
		RAA207704GBM	33		
		RAA207705GBM	39		

Note: 1. Not assured value, just reference for design. Above data is taken using Renesas's reference board.

Recommended Operating Condition

Item	Symbol	Ratings	Unit	Remarks
Input voltage	VIN	3.0 to 16	V	
Analog input voltage	AVIN	4.5 to 16	V	
Controller voltage	V5_OUT	4.5 to 5.5	V	When V5_OUT is supplied externally
Continuous output current	IOUT	0 to 15	A	15 A: RAA207703GBM 10 A: RAA207704GBM 5 A: RAA207705GBM
		0 to 10		
		0 to 5		

Electrical Characteristics

(Ta = 25°C, VIN = 12 V, unless otherwise specified)

	Item	Symbol	Min	Typ	Max	Unit	Test Conditions
Supply	AVIN start threshold	VH	—	4.3	4.5	V	
	AVIN shutdown threshold in CCM	VL	3.6	3.8	—	V	
	AVIN shutdown threshold in ELL mode	V _{LDCM}	—	3.0	3.6	V	In ELL mode (DCM, f _{sw} < 100 kHz)
	AVIN quiescent current	I _q	—	400	550	mA	Output = no load, ELL mode
	AVIN disable current (LDO_EN# = 12 V)	I _{IAIN-DISBL1}	—	70	150	mA	ON/OFF = 0 V, LDO_EN# = 12 V
	VIN disable current (LDO_EN# = 0 V)	I _{IAIN-DISBL2}	—	130	200	mA	ON/OFF = 0 V, LDO_EN# = 0 V
	AVIN operating current (RAA207703GBM)	I _{CIN}	—	40	—	mA	f _{sw} = 1 MHz, ton = 200 ns
	AVIN operating current (RAA207704GBM)	I _{CIN}	—	35	—	mA	
	AVIN operating current (RAA207705GBM)	I _{CIN}	—	20	—	mA	
	VIN disable current	I _{IIN-DISBL1}	—	—	5	mA	ON/OFF = 0 V
Remote ON/OFF	Disable level	V _{DISBL}	—	—	0.6	V	3.3 / 5.0 V interface
	Enable level	V _{ENBL}	2.0	—	—	V	
	Pull-down resistance	R _{DISBL}	0.7	1	1.3	MΩ	ON/OFF = 1 V
5 V LDO enable	5 V LDO on level	V _{LDO_ON}	—	—	0.6	V	
	5 V LDO off level	V _{LDO_OFF}	2.0	—	—	V	
	Pull-down resistance	R _{LDO}	0.7	1	1.3	MΩ	LDO_EN# = 1 V
5 V LDO output	5 V LDO output voltage	V _{LDO}	4.5	5.0	5.5	V	at no load
FB	Comparator threshold voltage	V _{FB_COMP}	792	800	808	mV	
	FB input current	I _{FB_IN}	-0.1	0	+0.1	mA	FB = 1 V
1shot timer	High MOSFET on pulse width	P _W	170	210	250	ns	VIN = 12 V, Rset = 30 kW
	High MOSFET minimum on pulse width	P _{MIN_ON}	—	70	—	ns	
	High MOSFET minimum off pulse	P _{MIN_OFF}	—	50	—	ns	
Power good indicator	Rising threshold on FB	V _{PG_rise}	0.67	0.72	0.77	V	
	Power good falling hysteresis	dV _{PG}	—	50	—	mV	
	Power good resistance	R _{PG}	0.25	0.5	1	kΩ	FB = 0 V
Soft start	Soft start bias current	I _{SS}	1.8	2.5	3.3	mA	
Over voltage protection	OVP trip voltage on FB	V _{OVP}	0.95	1.00	1.05	V	
Over current protection	OCP trip current (RAA207703GBM)	I _{OCP}	16.0	20.0	24.0	A	Fixed internally, inductor peak current *1
	OCP trip current (RAA207704GBM)	I _{OCP}	11.5	14.0	17.0	A	Fixed internally, inductor peak current *1
	OCP trip current (RAA207705GBM)	I _{OCP}	6.4	8.0	9.6	A	Fixed internally, inductor peak current *1
Over temperature protection	TSD trip temperature	T _{TSD}	130	150	—	°C	*1
	Temperature hysteresis	T _{hys}	—	15	—	°C	*1

Note: *1 Not directly tested. Assured by related characteristics test.

Efficiency Performance

(VIN = 12 V, L = 1 mH, fsw = 500 kHz (at CCM) no airflow, unless otherwise specified)

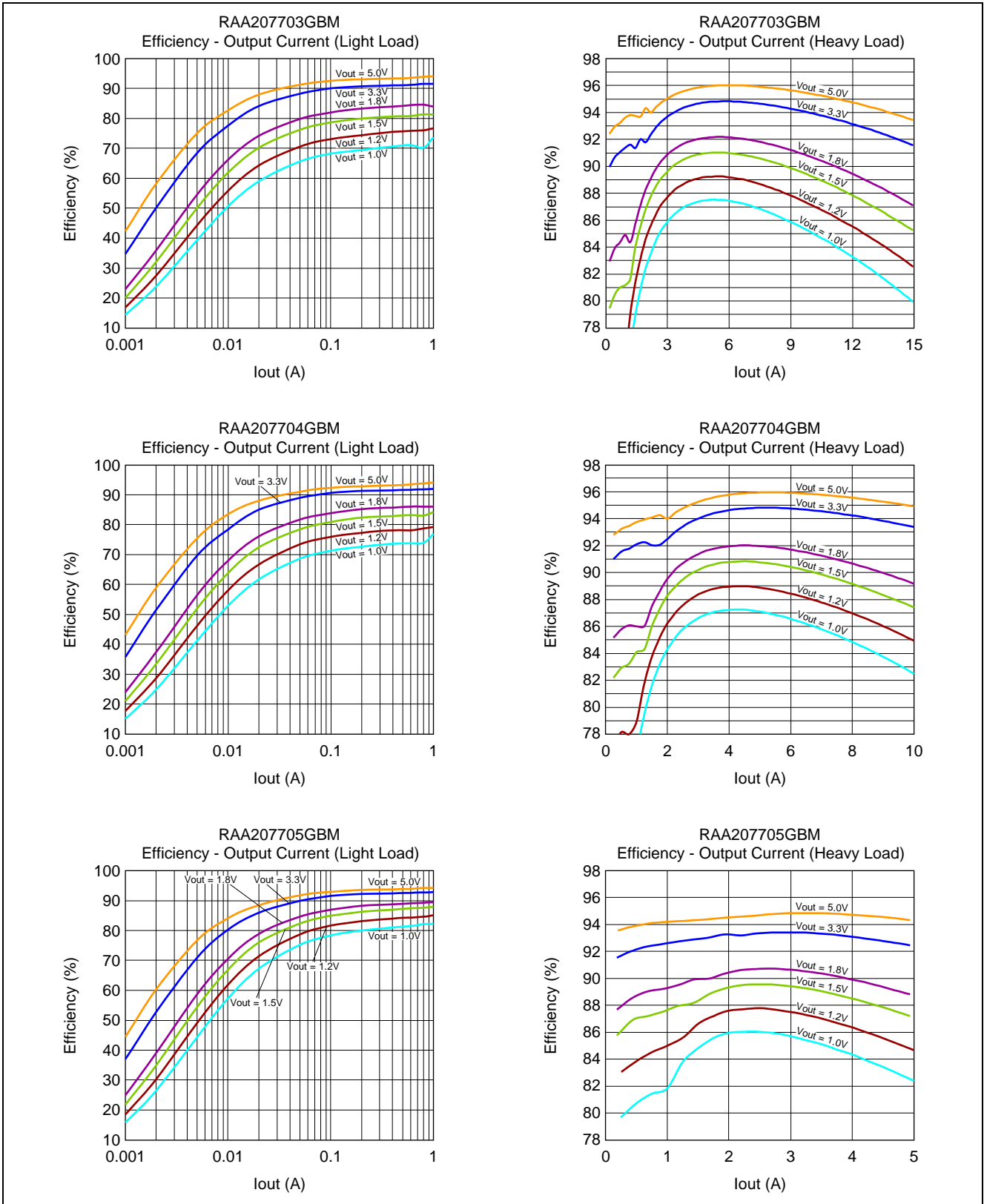

Operating Performance

(RAA207703GBM, $V_{IN} = 12\text{ V}$, $V_{out} = 1.2\text{ V}$, $L = 0.42\text{ mH}$, $C_{out} = 5 \cdot 47\text{ nF}$, $t_{on} = 130\text{ ns}$, unless otherwise specified)

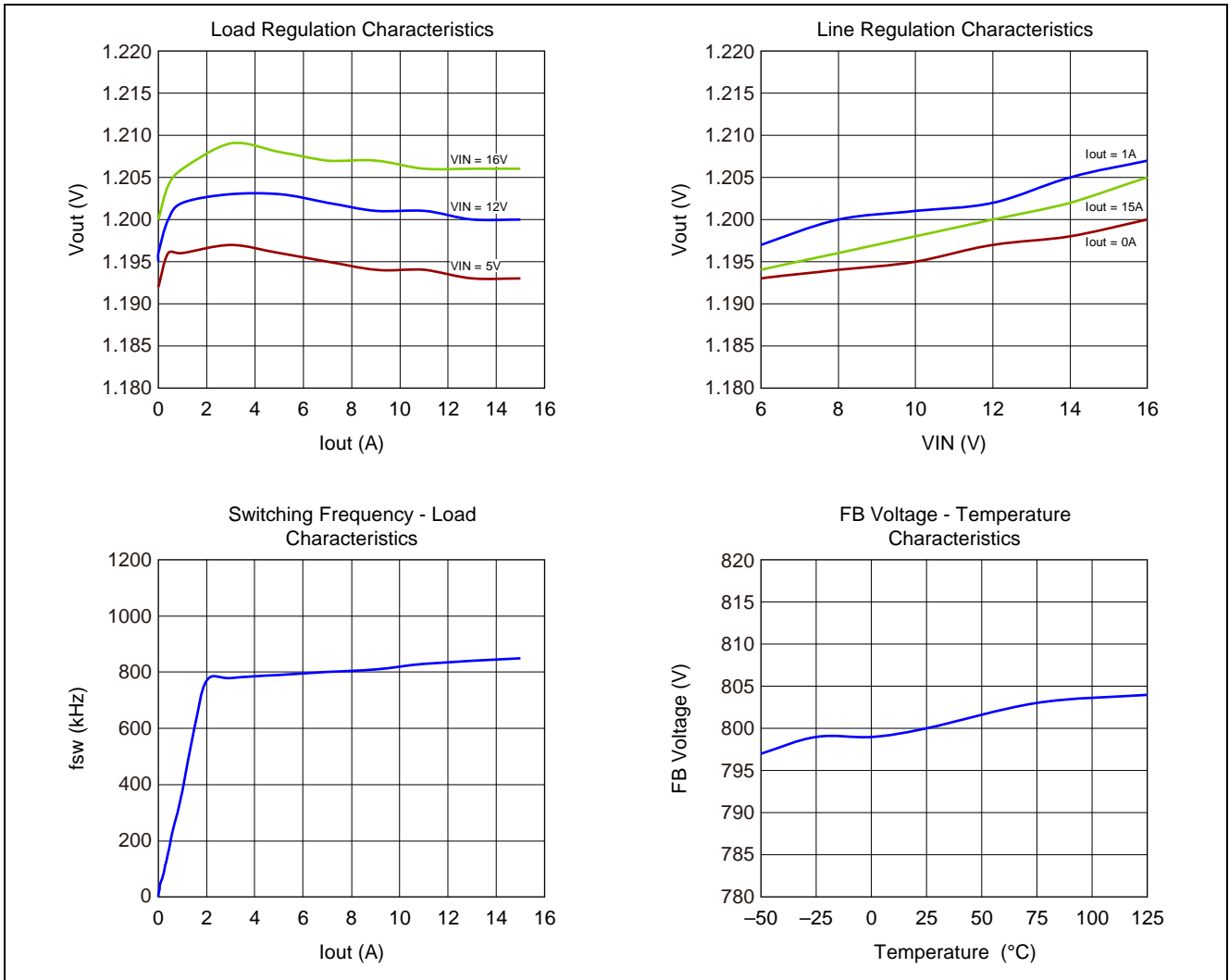

Operating Waveform

(RAA207703GBM, VIN = 12 V, Vout = 1.2 V, L = 0.42 mH, Cout = 5 * 47 nF, ton = 130 ns, unless otherwise specified)

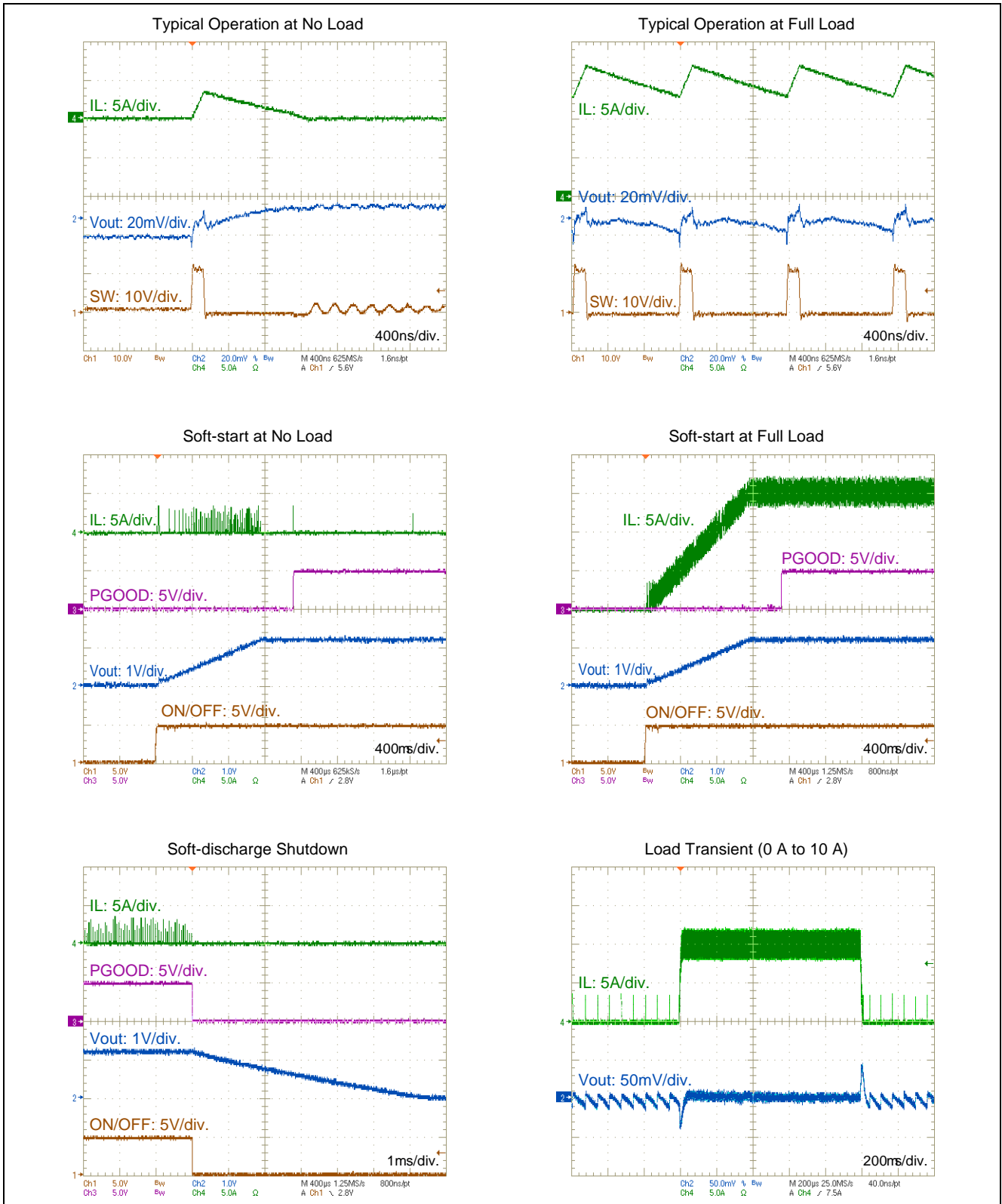

Description of Operation

The RAA207703GBM operates as voltage-ripple based constant on time control architecture. Converter output is controlled by output voltage ripple which is determined by inductor ripple current and ESR & ESL of output capacitor. Each switching cycle starts High-side MOSFET turn on which time is decided by 1 shot timer. After High-side MOSFET turns off, Low side turns on, and it keeps until FB voltage becomes lower than reference voltage. In light load condition, Low-side MOSFET on time is decided by inductor zero current.

Switching Frequency, Constant on Time Setting

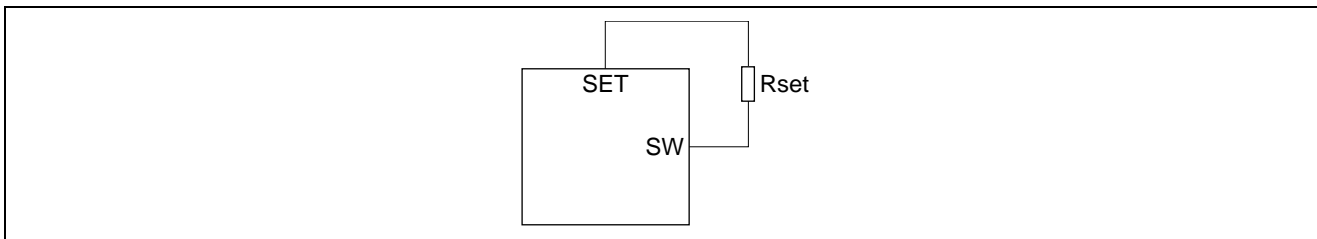

Switching Frequency in CCM mode is determined by following equation.

$$\text{Switching Frequency: } (V_{out} / V_{IN}) \cdot (1 / t_{on}) \text{ [Hz]} \quad (1)$$

Here, t_{on} is High-side MOSFET on time, and it is determined by following equation.

$$\text{On time pulse: } (50 \text{ pF} \cdot 1 \text{ V} / (V_{IN} - 2.0 \text{ V})) \cdot R_{set} + 60 \text{ ns [s]} \quad (2)$$

From above equation, constant on time is change depend on V_{IN} , so switching frequency is almost constant when V_{IN} change. This architecture is suitable for battery application. From the above equation, R_{set} is calculated by

$$R_{set: } (V_{out} / (V_{IN} \cdot F_{sw}) - 60 \text{ ns}) \cdot (V_{IN} - 2.0 \text{ V}) / (50 \text{ pF} \cdot 1 \text{ V}) \text{ [}\Omega\text{]} \quad (3)$$

Here, F_{sw} is switching frequency.

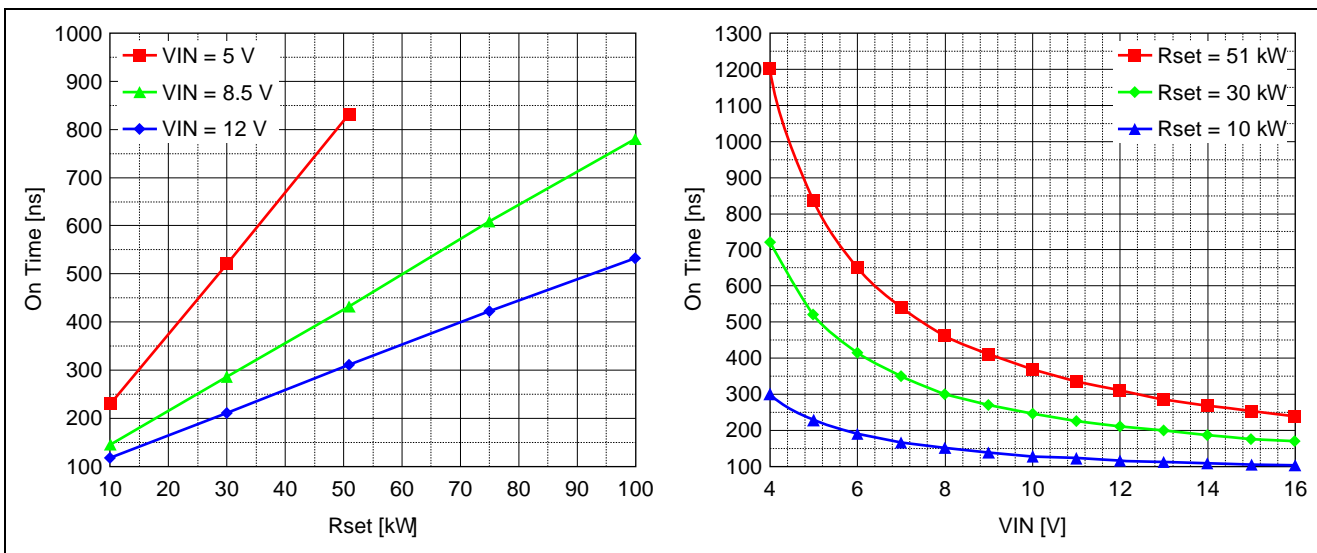

Minimum on time is 70 ns (typ.), so recommended on time pulse is more than 100 ns. Maximum operating frequency is restricted by minimum on time and minimum off time (50 ns, please see next chapter).

Maximum Duty Cycle Operation

Maximum duty cycle is restricted by following equation.

$$\text{Max. duty: } 1 - (50 \text{ ns} \cdot F_{sw}) \frac{1}{4} \quad (4)$$

Here, 50 ns means High-side minimum off time.

If FB voltage does not reach reference voltage after the High-side MOSFET turn on time is expired, Low-side MOSFET turns on 50 ns, and next switching cycle starts. Especially, this condition occurs when output load transient state.

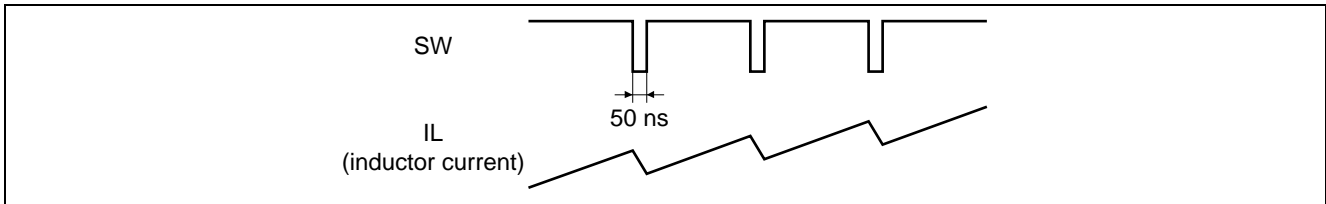

Soft Start

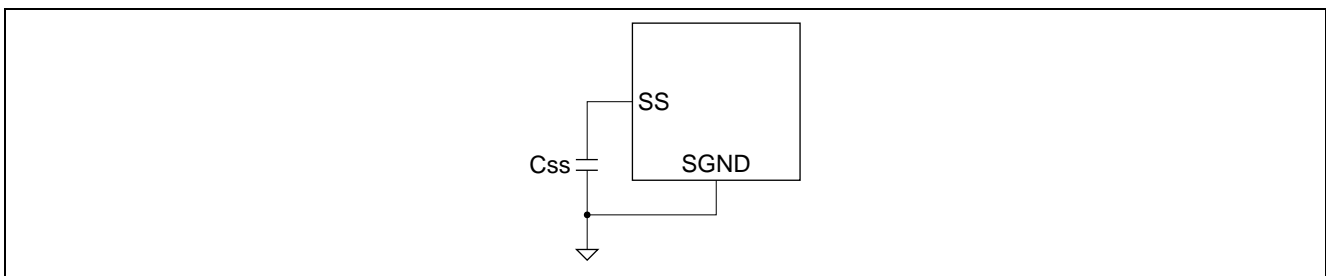

Soft start ramp period is adjustable by external capacitor (Ccss) selection. When converter start operating, 2.5 mA current from SS pin charges capacitor between SS and GND. Soft start period is determined by following equation.

$$\text{Soft Start period: } C_{css} \cdot 0.8 \text{ V} / 2.5 \text{ mA [s]} \frac{1}{4} \quad (5)$$

Here, 0.8 V is internal reference voltage Vref. IC operates diode emulation mode at Soft start period, so it can prevent from reverse current when pre-bias condition. Soft start restarts when Enable signal re-entered, and after OCP, OVP, TSD, UVL release condition.

Power Good Indicator

Power good indicator is useful for controlling multi-converter systems for sequential start up and shut down. FB voltage is monitored continuously by power good comparator. The power good comparator compares FB pin and 90% internal reference voltage (0.72 V). When FB reaches reference voltage, PGOOD pin becomes high impedance after internal delay (30% of soft start period). Under the fault condition (UVLO, OVP, OCP, TSD), PGOOD pin is pulled low.

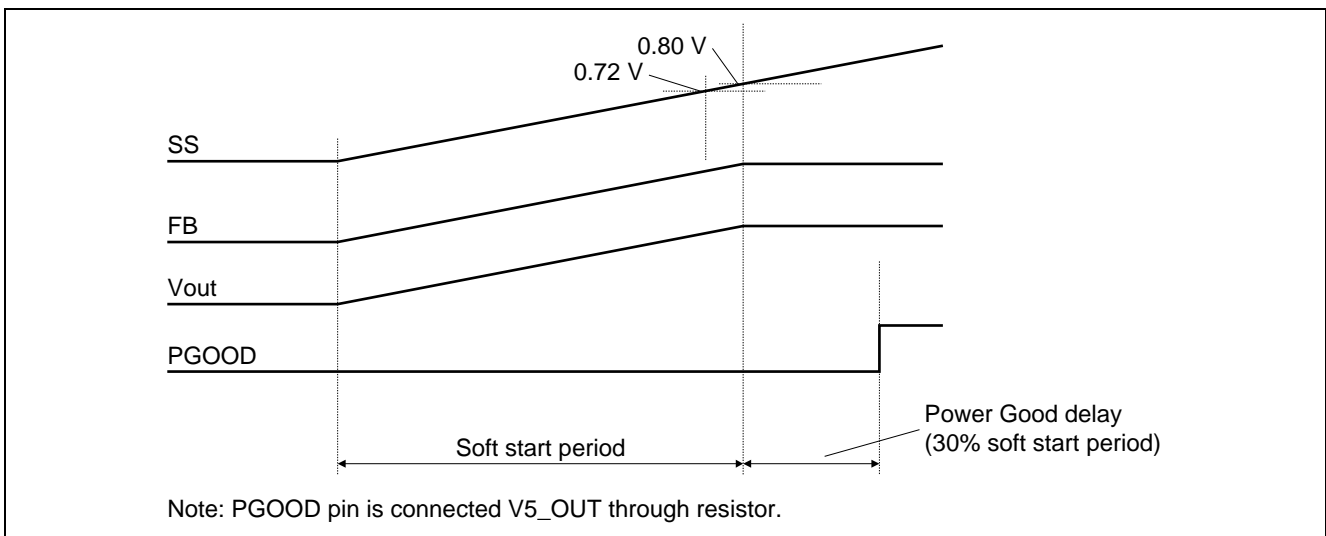

Over Voltage Protection (OVP)

When FB voltage exceeds 125% of reference voltage (1.00 V), switching stops immediately and latched Low-side MOSFET on state in order to pull the output voltage. To leave the OVP condition, V5_OUT needs to be pulled under the UVLO level, and re-enter the signal.

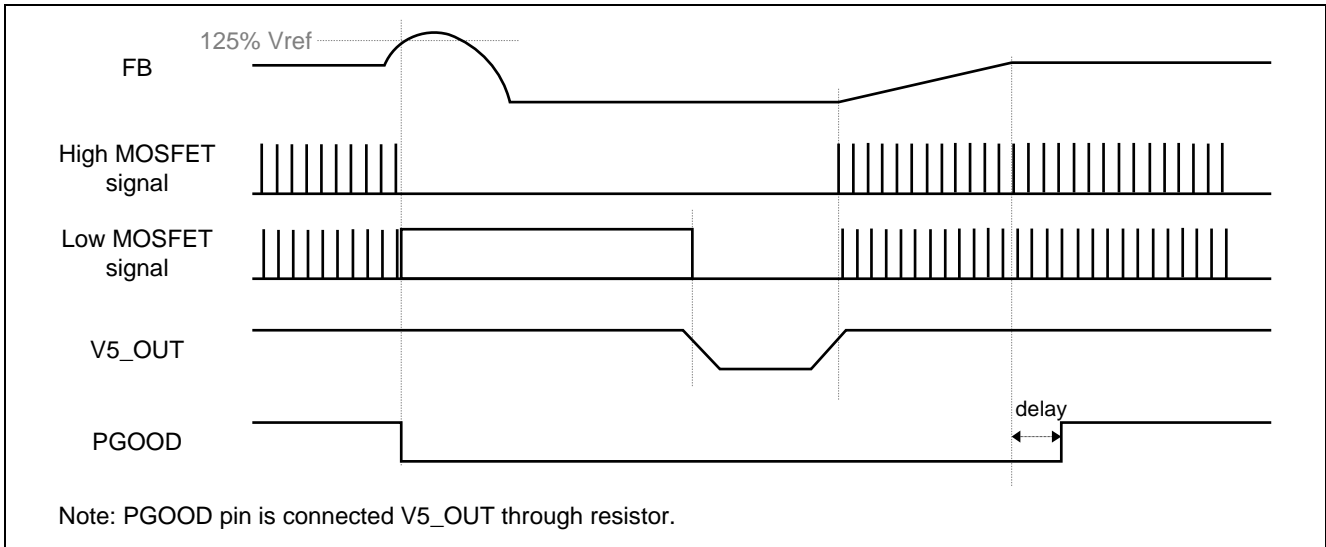

Over Current Protection (OCP)

OCP detection circuit monitors High-side MOSFET drain-source current. When the current exceeds fixed level four times, IC starts hiccup operation. In the hiccup operation, switching stops and operate 1 ms timer. After 1 ms timer is expired, IC operates again from soft start state. If IC detect OCP in the soft start circuit, hiccup operation start again.

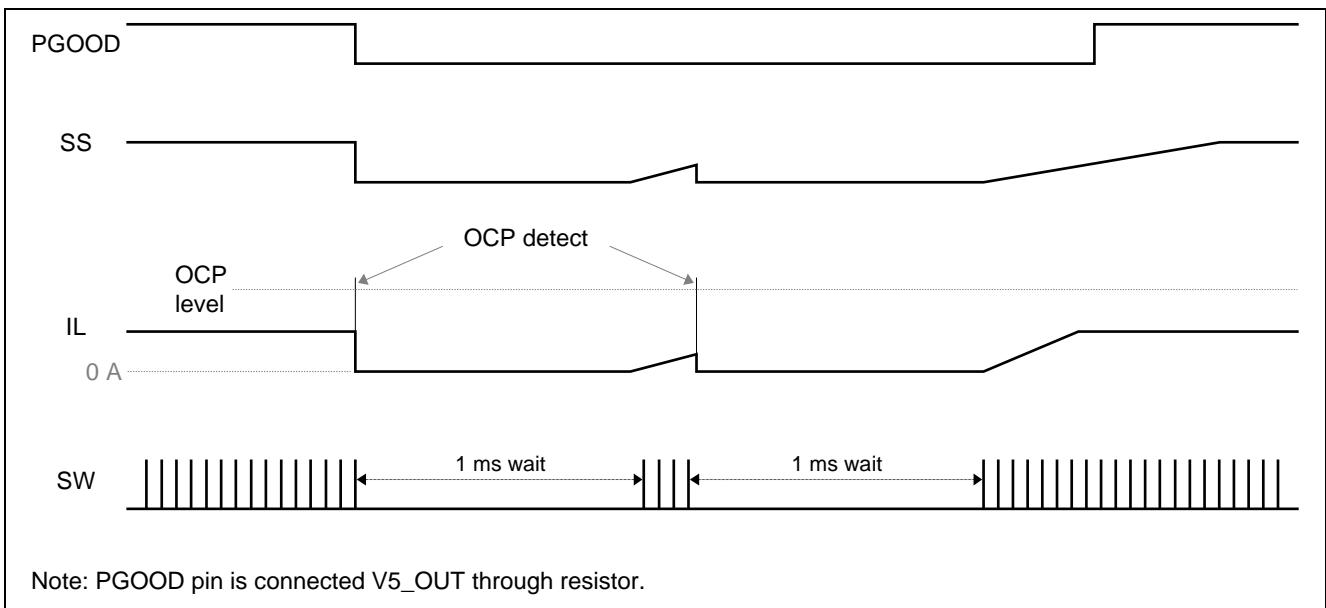

Thermal Shutdown (TSD)

Thermal sensor monitors junction temperature of IC. When junction temperature exceeds 150°C, switching stops. After junction temperature become 135°C, IC restart switching from soft start (Non-latched function).

Enhanced Light Load Function (ELL)

IC operates diode emulation mode in light load condition. To enhance light load efficiency, IC detects light load condition automatically, and operate as Enhanced Light Load mode (ELL). In ELL mode, bias current of IC becomes small, so this function can improve the efficiency.

Start-up Sequence for External 5 V Use

When LDO function is used, start-up sequence is free. However, it needs specific start-up sequence when LDO function is not used. Please set start-up sequence from following. IC cannot start-up when "V5_OUT & ON/OFF rise first, VIN rises secondly" sequence.

(1) VIN to V5_OUT (ON/OFF is pulled up to V5_OUT)

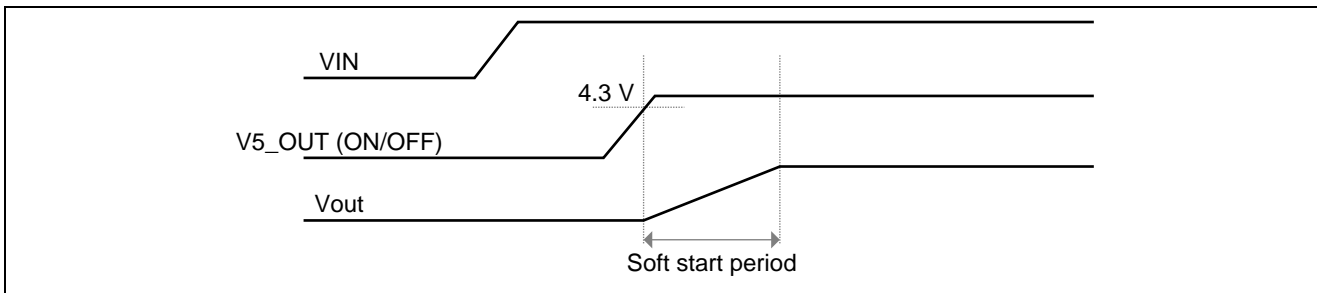

(2) VIN or V5_OUT to ON/OFF (ON/OFF = "H" asserted after VIN & V5_OUT rise)

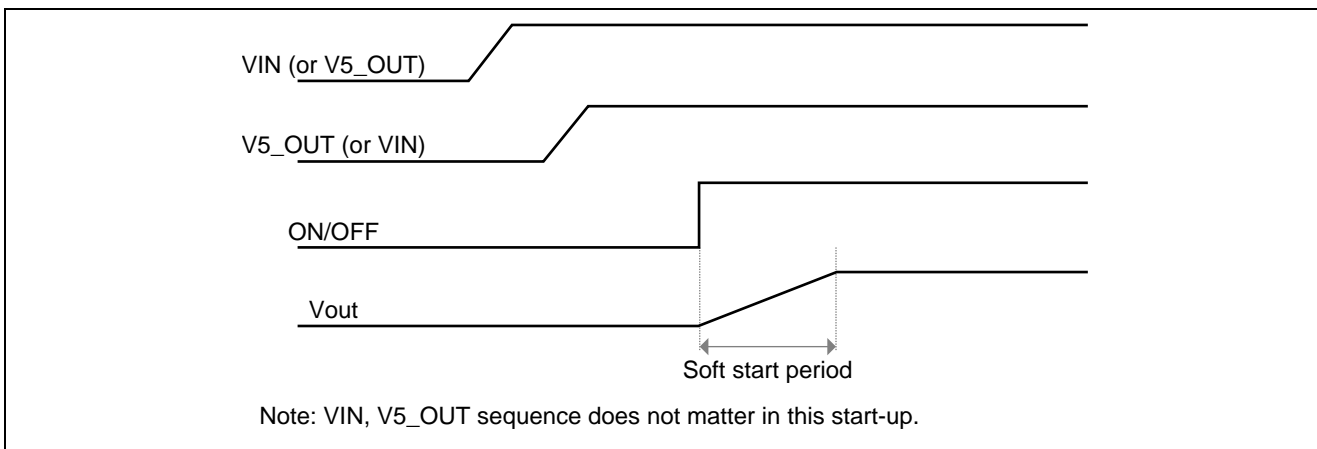

ON/OFF Pin Slew Rate Restriction

When ON/OFF pin is driven by another controller, the slew rate of H to L transition must be higher than -5 V/ms monotonically (must be rapid transition). If the slew rate is lower than -5 V/ms (slow transition), switching noise affect ON/OFF pin input circuit and lead to malfunction in case of heavy load state. Recommended drive impedance of ON/OFF pin is less than 10 kΩ. If ON/OFF pin is always pulled up to V5_OUT or VIN via resistance, slew rate is not a matter.

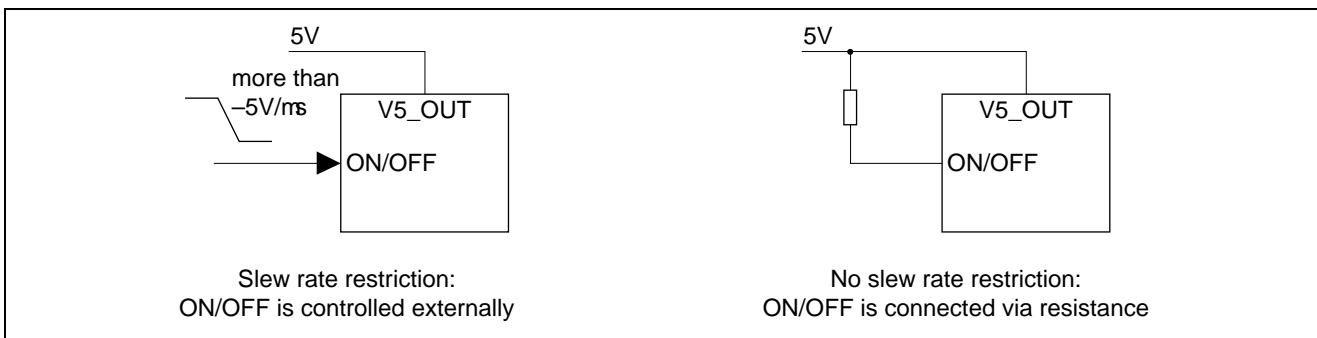

Controller Power Supply

The RAA207703GBM incorporates internal 5 V LDO, so it can operate with single power supply. LDO_EN# can control LDO operation, and select the controller power supply from LDO or V5_OUT pin. When LDO_EN# = H state, external 5 V should be applied to V5_OUT pin and AVIN pin.

Typical pin connection of each operation are below.

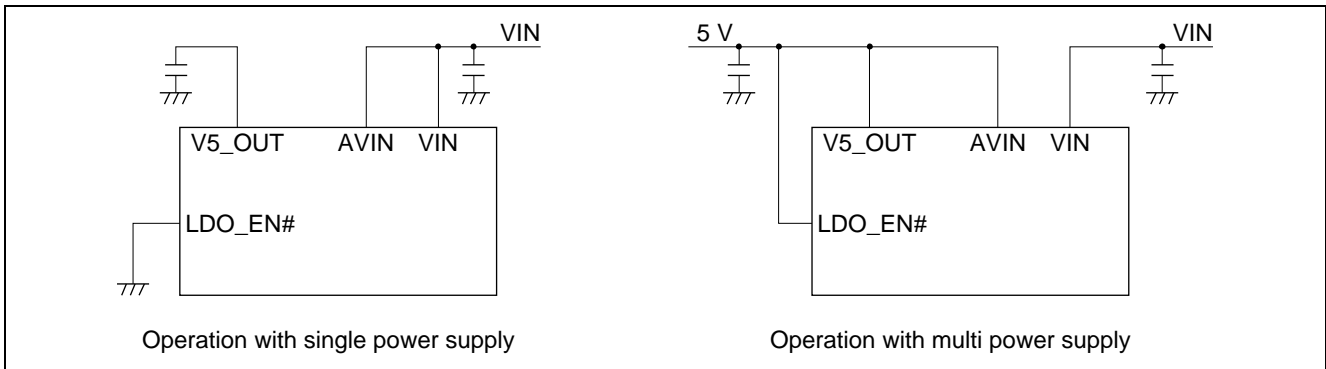

Note: Truth table for LDO_EN# pin

LDO_EN# Input	5 V Regulator Status
"L"	LDO enable
"Open"	LDO enable
"H"	LDO disable

Stability Criteria, Output Voltage Setting for High ESR Output Capacitor

Small output ripple voltage makes control loop unstable in constant on time architecture. Ripple voltage needs to be larger than 15 mV on FB pin. When using high ESR (>50 mW) capacitor such as Electrolytic capacitor, Polymer aluminum capacitor for output capacitor, ripple voltage on FB pin will be more than 15 mV.

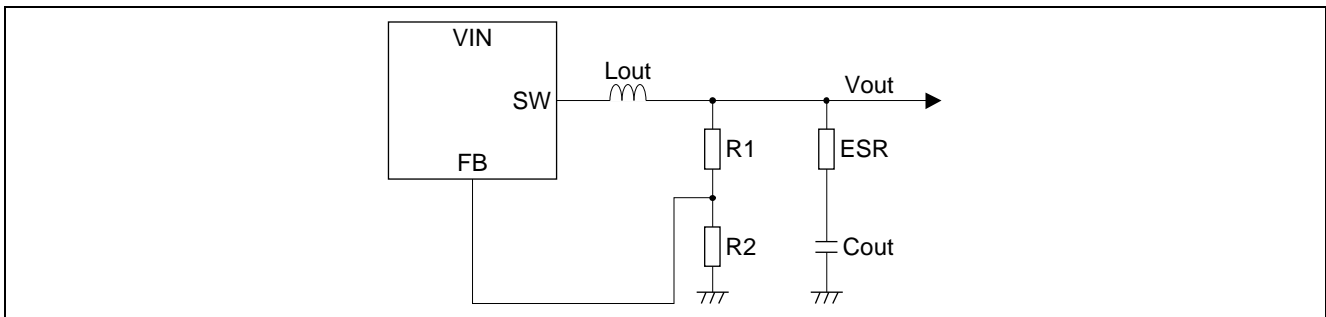

Stability criteria

From loop stability analysis, constant on time control system must satisfy below equation.

$$\text{Stability criteria: } ESR \cdot C_{out} > t_{on} / 2 \frac{1}{4} \quad (6)$$

Here, t_{on} is constant on time. If the system cannot satisfy above equation, subharmonic oscillation will occur.

Vout setting

FB comparator compares FB voltage and internal accurate reference voltage (0.8 V). Feedback loop controls FB voltage to match the reference voltage. However, Vout ripple voltage affects FB voltage. So, effective FB pin voltage Vfb will be below. (Here, Vout ripple from bulk capacitance is ignored)

$$\text{Effective FB voltage (Vfb): } 0.8 \text{ V} + \frac{1}{2} ((VIN - Vout) \cdot t_{on} \cdot ESR \cdot R2 / (Lout \cdot (R1 + R2))) \text{ [V]} \frac{1}{4} \quad (7)$$

Here, R1 and R2 is output voltage divider resistor, Lout is inductance of output filter and ESR means ESR of output capacitor (refer to above figure). 0.8 V in above equation means reference voltage of IC. Considering Vout ripple voltage, Vout voltage becomes below equation.

$$Vout: Vfb \cdot (R1 + R2) / R2 \text{ [V]} \frac{1}{4} \quad (8)$$

Operating with Small ESR Output Capacitor

When using low-ESR output capacitor like MLCC, voltage ripple on output voltage node is very small. So, voltage ripple needs to be enhanced by additional components. Recommended ripple enhance method is like below figure.

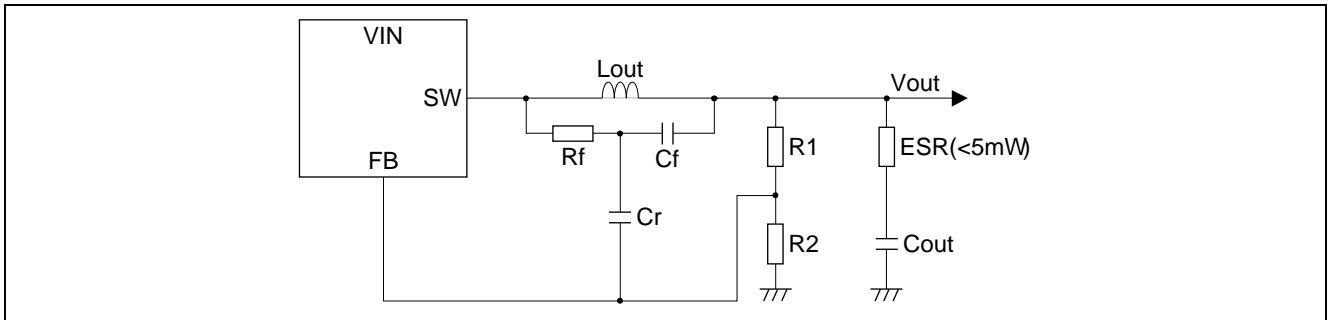

Ripple injection on FB pin

R_f and C_f make ripple voltage using inductor DCR ripple. C_r is used for AC ripple injection to FB pin. Ripple voltage between R_f and C_f is described by following equation.

$$V_{\text{ripple}}: (V_{\text{IN}} - V_{\text{out}}) \cdot t_{\text{on}} / (R_f \cdot C_f) [V] \quad (9)$$

$$R_f: (V_{\text{IN}} - V_{\text{out}}) \cdot t_{\text{on}} / (V_{\text{ripple}} \cdot C_f) [V] \quad (10)$$

Recommended ripple voltage is between 15 mV and 20 mV.

Stability criteria

To keep voltage ripple amplitude on FB pin, below equation should be satisfied.

$$\text{Stability criteria(1): } 1 / (2\pi \cdot C_f \cdot F_{\text{sw}}) \ll 1 / (2\pi \cdot C_r \cdot F_{\text{sw}}) \ll R_1 \cdot R_2 / (R_1 + R_2) \quad (11)$$

Here, F_{sw} means switching frequency at CCM mode. Recommended value for $C_f = 0.01 \text{ nF}$, and $C_r = 1000 \text{ pF}$. R_1 and R_2 are recommended between 10 k Ω and 100 k Ω .

From loop stability analysis of above circuit configuration, the system must satisfy below equation.

$$\text{Stability criteria(2): } L_{\text{out}} \cdot C_{\text{out}} / (R_f \cdot C_f) > t_{\text{on}} / 2 \quad (12)$$

If the system cannot satisfy above equation, subharmonic oscillation will occur. Capacitance - voltage dependence is must be considered when MLCC use.

Vout setting

Additional ripple voltage and ESR voltage ripple also affects V_{out} accuracy. From above figure, total ripple voltage on FB pin is described by below equation.

$$\text{Ripple voltage on FB pin: } (V_{\text{IN}} - V_{\text{out}}) \cdot t_{\text{on}} / (R_f \cdot C_f) + (V_{\text{IN}} - V_{\text{out}}) \cdot t_{\text{on}} \cdot ESR / (L_{\text{out}}) [V] \quad (13)$$

Effective FB pin voltage is described by below equation.

Effective FB voltage (V_{fb}):

$$0.8 V + \frac{1}{2} ((V_{\text{IN}} - V_{\text{out}}) \cdot t_{\text{on}} / (R_f \cdot C_f) + (V_{\text{IN}} - V_{\text{out}}) \cdot t_{\text{on}} \cdot ESR / (L_{\text{out}})) [V] \quad (14)$$

So, actual V_{out} voltage is described by below equation.

$$V_{\text{out}}: V_{\text{fb}} \cdot (R_1 + R_2) / R_2 [V] \quad (15)$$

BOOT Resistance

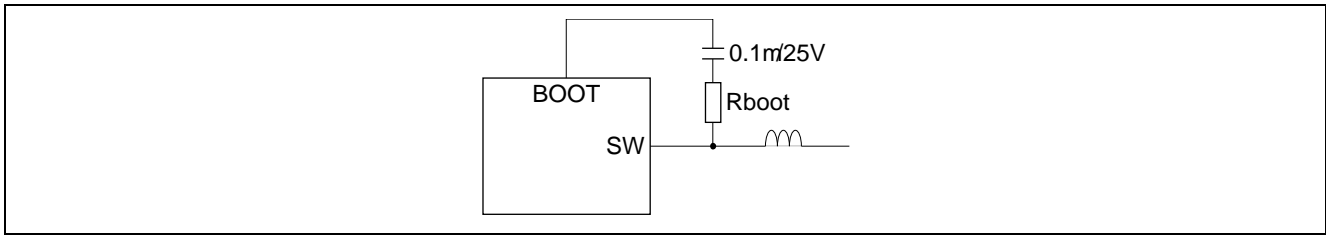

SW node spike occurs when IC is operating. Turn-on spike voltage exceeds absolute maximum voltage of SW pin depends on operating condition. To suppress the spike voltage, adding boot resistor (Rboot) is effective. Recommended Rboot is below.

Part No.	Recommended Rboot	
	VIN = 12 V	VIN = 5 V
RAA207703GBM	3.9 W	0 W
RAA207704GBM	2.0 W	0 W
RAA207705GBM	0 W	0 W

Design Example

(VIN = 12 V, Vout = 1.2 V, Fsw = 500 kHz (at CCM), L = 0.47 mH)

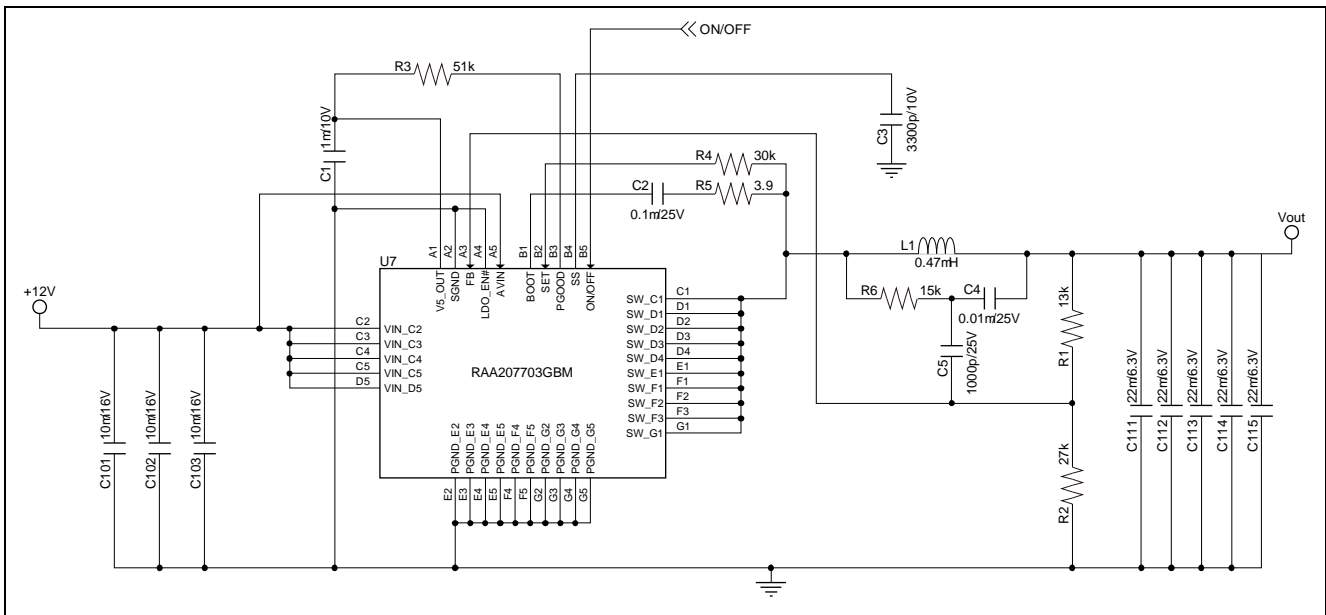

1. Setting of ton (constant on time)

In this condition, calculated on time is from equation (1),

$$\text{Calculated ton: } 1.2 \text{ V} / 12 \text{ V} \cdot (1 / 500 \text{ kHz}) = 200 \text{ ns}$$

From equation (3),

$$\text{Calculated R4} = (1.2 \text{ V} / (12 \text{ V} \cdot 500 \text{ kHz}) - 60 \text{ ns}) \cdot (12 \text{ V} - 2 \text{ V}) / (50 \text{ pF} \cdot 1 \text{ V}) = 28 \text{ kW}$$

so choose R4 = 30 kW from E24 series.

So, actual on pulse ton is decided by equation (2),

$$\text{Constant on time: } ((50 \text{ pF} \cdot 1 \text{ V} / (12 \text{ V} - 2 \text{ V})) \cdot 30 \text{ kW} + 60 \text{ ns}) = 210 \text{ ns}$$

2. Setting of ripple injection resistance

Voltage ripple on FB pin needs to be more than 15 mV. Here, C4 = 0.01 nF, C5 = 1000 pF and ESR of output cap = 0.5 mW. To obtain 15 mV additional ripple on FB pin from R6, C4 and C5 network circuit, R6 is calculated by equation (10).

$$\text{Calculated R6: } (12 \text{ V} - 1.2 \text{ V}) \cdot 210 \text{ ns} / (15 \text{ mV} \cdot 0.01 \text{ nF}) = 15.1 \text{ kW}$$

So choose R6 = 15 kW from E24 series and actual ripple voltage from injection circuit becomes 15.1 mV.

So, Total ripple voltage on FB pin is calculate by equation (13),

Total ripple voltage:

$$(12 \text{ V} - 1.2 \text{ V}) \cdot 210 \text{ ns} / (15 \text{ kW} \cdot 0.01 \text{ nF}) + (12 \text{ V} - 1.2 \text{ V}) \cdot 210 \text{ ns} / 0.47 \text{ mH} \cdot 0.5 \text{ mW} = 17.5 \text{ mV}$$

3. Setting of output voltage resistor

From above setting, effective FB voltage is from equation (15),

$$\text{Effective FB voltage: } 800 \text{ mV} + 17.5 \text{ mV} / 2 = 808.8 \text{ mV}$$

When R1 = 13 kW, R2 is decided from equation (15).

$$\text{R2} = 13 \text{ kW} / ((1.2 \text{ V} / 808.8 \text{ mV}) - 1) = 26.8 \text{ kW}$$

So, choose R2 = 27 kW from E24 series.

4. Stability criteria confirmation

For output capacitor, please confirm stability criteria. Stability criteria from equation (11),

$$1 / (2p \cdot 0.01 \text{ nF} \cdot 500 \text{ kHz}) = 32 \text{ W} \ll 1 / (2p \cdot 1000 \text{ pF} \cdot 500 \text{ kHz}) = 318 \text{ W} \ll 13 \text{ kW} \cdot 27 \text{ kW} / (13 \text{ kW} + 27 \text{ kW}) = 8.8 \text{ kW}$$

so, above criteria is satisfied.

For output capacitor, please confirm stability criteria. Stability criteria from equation (12),

$$C_{out} > (210 \text{ ns} / 2) \cdot 15 \text{ kW} \cdot 0.01 \text{ nF} / 0.47 \text{ mH} = 34 \text{ nF}$$

So, choose 110 nF (22 nF ´ 5 pcs.) for output capacitor. Here, please consider voltage dependence of capacitor.

If you cannot satisfy above criteria, please consider below changes.

¾ increase L or Cout value

¾ increase frequency (decrease constant on time)

¾ change Rf value.

5. Other components

C1 = 1 nF / 10 V and C2 = 0.1 nF / 25 V are recommended. C3 decides soft start period from equation (5). R5 is decided from the table in “Boot Resistance” section. Input and output capacitors are decided considering voltage ripple, current ripple and voltage tolerance.

Board Layout Example (RAA207703GBM)

Board layer example: 4 layer, internal 2nd and 3rd layer are used for GND plane.

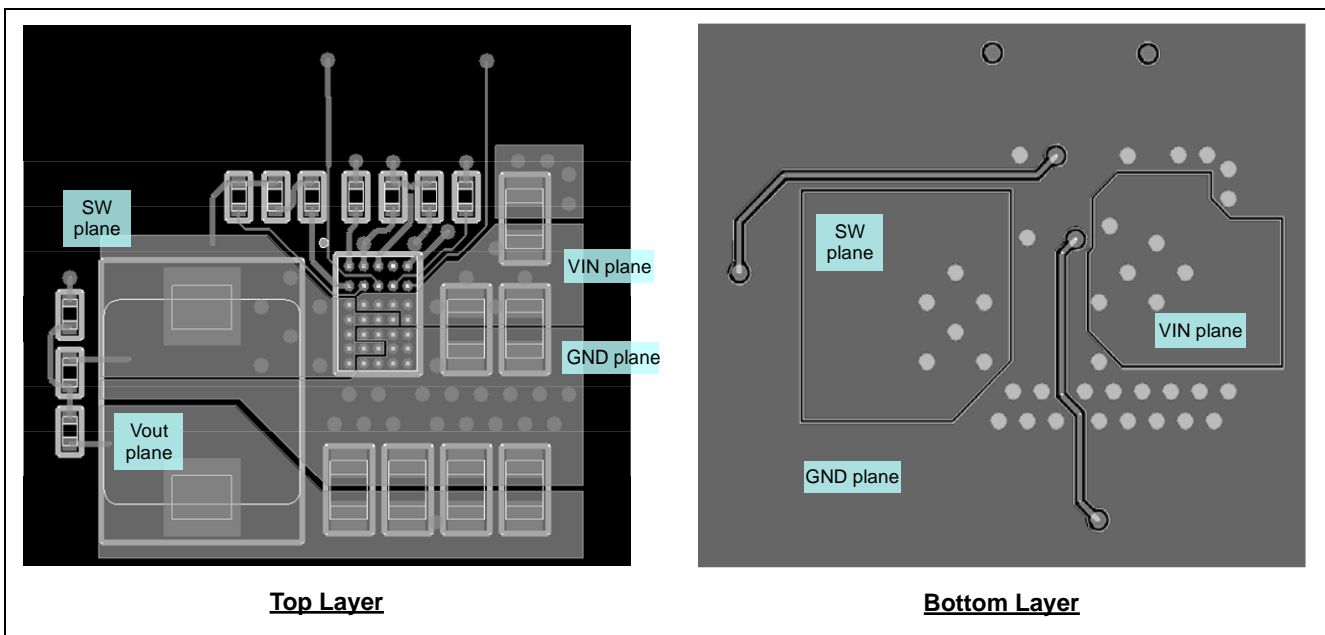

1. Power part
 - ¾ Input capacitor should be placed close to VIN and PGND pin to reduce switching noise and to improve the efficiency.
 - ¾ Many thermal via should be placed on VIN, SW and PGND planes to spread heat to board. Furthermore, VIN, SW planes on bottom layer are effective for thermal spread (If available).
2. Control part
 - ¾ Decoupling capacitor between V5_OUT and SGND should be placed as close as possible to the chip in order to stable operation.
 - ¾ Also, SGND, PGND via should be placed as close as possible to the chip, and connect each pin low impedance by internal GND plane.
 - ¾ FB resistance should be placed close to chip and FB wiring should be short to avoid noise. Furthermore, additional ripple circuit wiring should be kept away from high dv/dt plane such as SW and BOOT wiring.
 - ¾ To ensure the reliability of chip - board connection, we recommend Solder Mask Defined (SMD) layout. But you can also use Non-Solder Mask Defined (NSMD) layout as far as you can ensure the reliability. In the case of SMD layout, we recommend below size.
Solder resist open size: 280 μm , Land size: 280 μm + 50 to 100 μm (please consider processing accuracy)

Representative Inductors

Maker	Inductance [nH]	DL/L0 = 20% Change [A]	Dimensions [mm]
NEC Tokin MPC series	0.42	20.0	6.7 ´ 8.0 ´ 4.0
	0.60	19.0	6.7 ´ 8.0 ´ 5.0
	0.88	24.0	10.0 ´ 11.5 ´ 4.0
	1.0	25.0	10.0 ´ 11.7 ´ 5.5
ALPS Green Device GLMC series	0.47	13.9 ^{*1}	6.5 ´ 7.4 ´ 3.0
	1.0	10 ^{*1}	6.5 ´ 7.4 ´ 3.0
	1.5	8.8 ^{*1}	6.5 ´ 7.4 ´ 3.0
TOKO FDVE0630 series	0.33	15.9	6.7 ´ 7.4 ´ 3.0
	0.47	15.6	6.7 ´ 7.4 ´ 3.0
	0.75	10.9	6.7 ´ 7.4 ´ 3.0
	1.0	9.5	6.7 ´ 7.4 ´ 3.0
TDK SPM5030 series	0.35	14.9	5.0 ´ 5.2 ´ 3.0
	0.47	11.0	5.0 ´ 5.2 ´ 3.0
	0.75	9.7	5.0 ´ 5.2 ´ 3.0

Note: ^{*1} 30% change

• Small size inductor for RAA207705GBM

Maker	Inductance [nH]	DL/L0 = 30% Change [A]	Dimensions [mm]
TOKO FDSD0420 series	0.68	8.3	4.2 ´ 4.2 ´ 2.0
	1.0	6.8	4.2 ´ 4.2 ´ 2.0
	1.5	5.7	4.2 ´ 4.2 ´ 2.0
TDK SPM4012 series	0.47	8.3	4.4 ´ 4.1 ´ 1.2
	1.0	4.8	4.4 ´ 4.1 ´ 1.2

Representative Output Capacitors

Maker	Maximum Voltage [V]	Capacitance [nF]
Sanyo POSCAP series	2.0 to 10	47 to 330
Sanyo OS-CON series	2.0 to 10	47 to 330
Murata MLCC series	6.3 to 10	22 to 47
TDK MLCC series	6.3 to 10	22 to 47
TAIYO YUDEN MLCC series	6.3 to 10	22 to 47

Package Dimensions

• RAA207703GBM

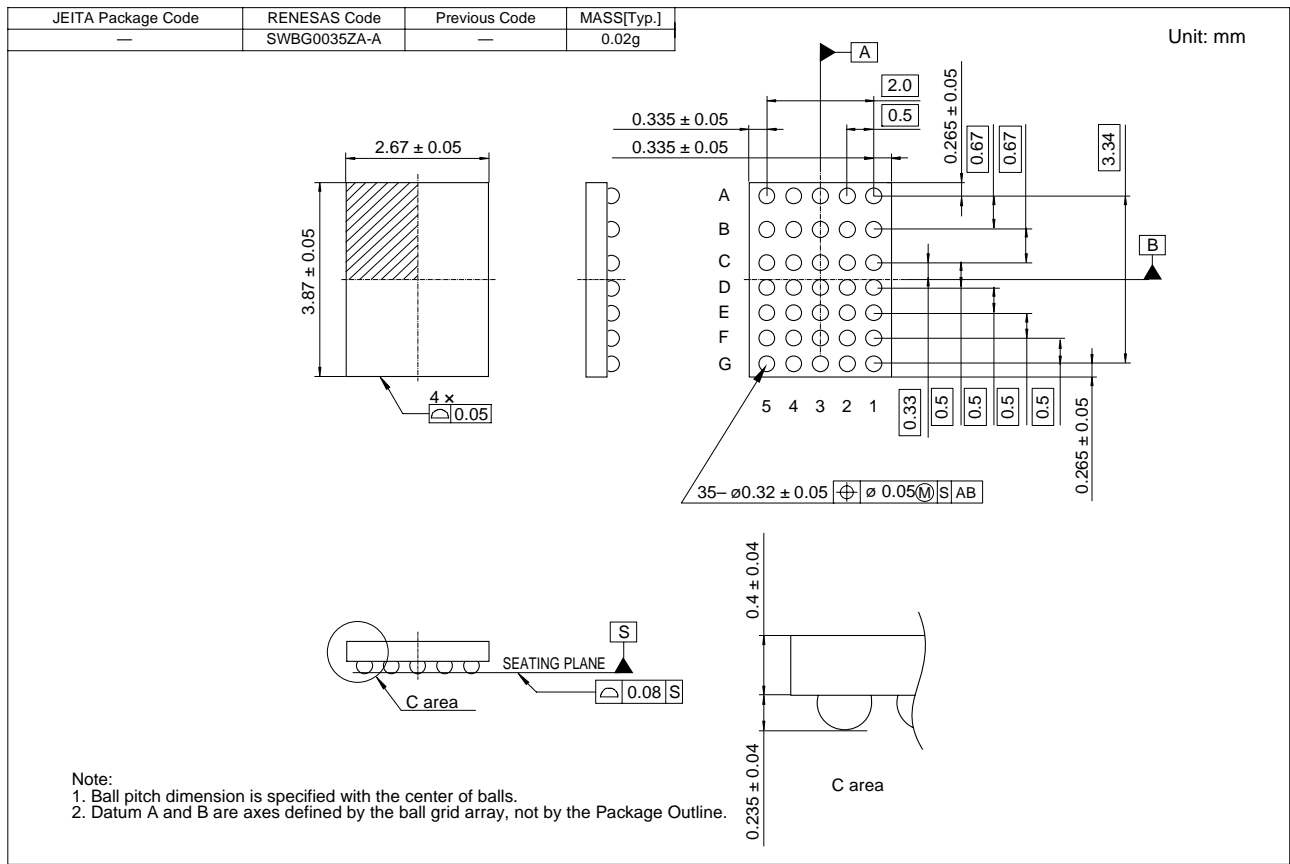

· RAA207704GBM

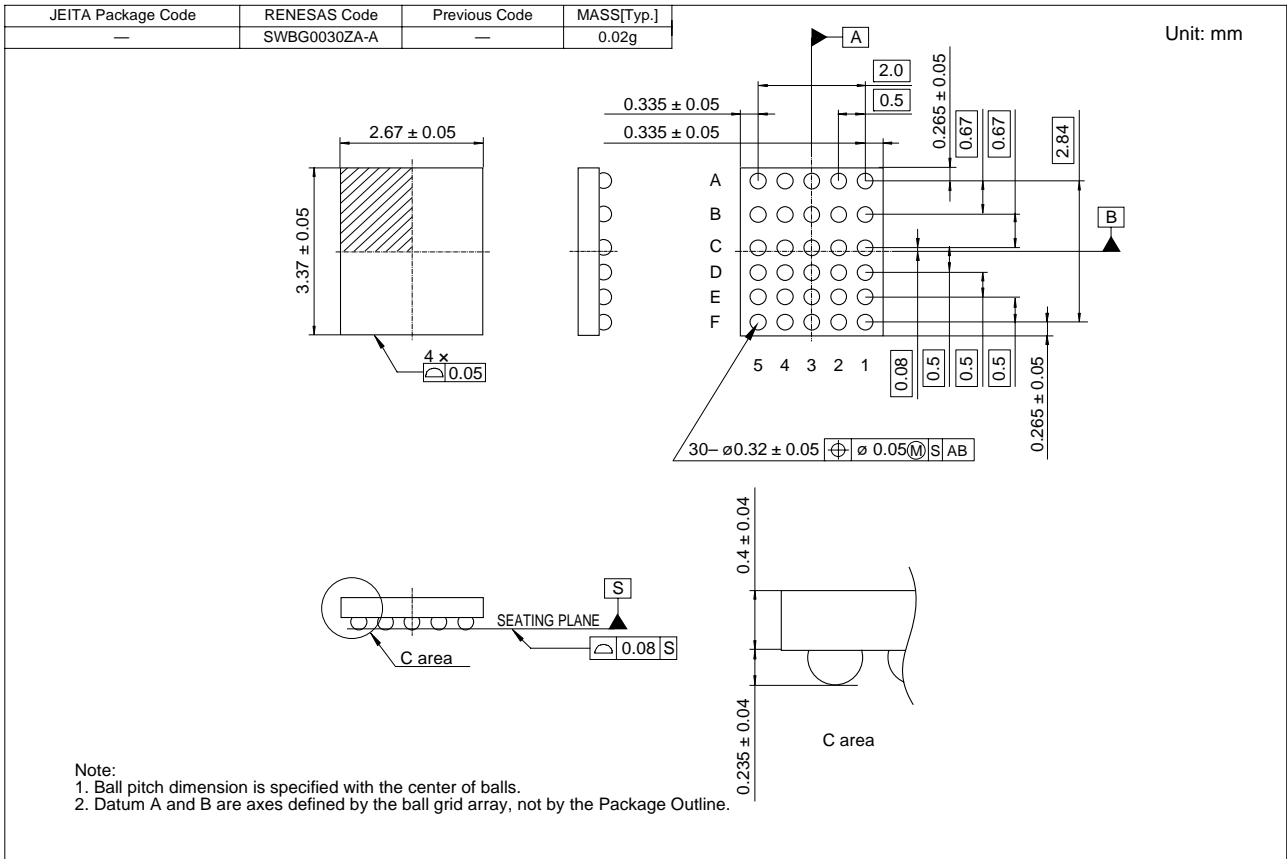

RAA207705GBM

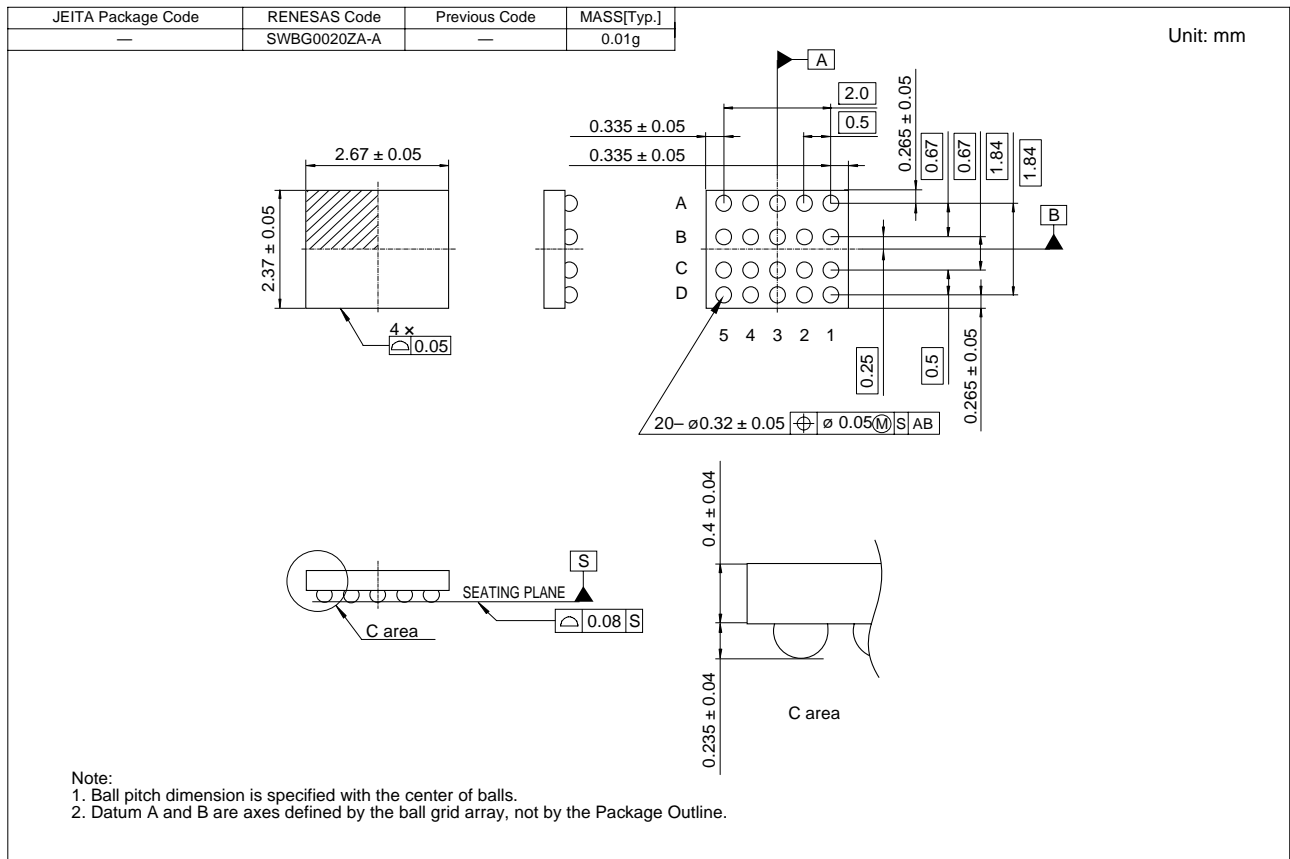

Ordering Information

Part Name	Quantity	Shipping Container
RAA207703GBM#HC0	2000 pcs	Taping Reel
RAA207704GBM#HC0	2000 pcs	Taping Reel
RAA207705GBM#HC0	2000 pcs	Taping Reel

Notice

1. Descriptions of circuits, software and other related information in this document are provided only to illustrate the operation of semiconductor products and application examples. You are fully responsible for the incorporation of these circuits, software, and information in the design of your equipment. Renesas Electronics assumes no responsibility for any losses incurred by you or third parties arising from the use of these circuits, software, or information.
2. Renesas Electronics has used reasonable care in preparing the information included in this document, but Renesas Electronics does not warrant that such information is error free. Renesas Electronics assumes no liability whatsoever for any damages incurred by you resulting from errors in or omissions from the information included herein.
3. Renesas Electronics does not assume any liability for infringement of patents, copyrights, or other intellectual property rights of third parties by or arising from the use of Renesas Electronics products or technical information described in this document. No license, express, implied or otherwise, is granted hereby under any patents, copyrights or other intellectual property rights of Renesas Electronics or others.
4. You should not alter, modify, copy, or otherwise misappropriate any Renesas Electronics product, whether in whole or in part. Renesas Electronics assumes no responsibility for any losses incurred by you or third parties arising from such alteration, modification, copy or otherwise misappropriation of Renesas Electronics product.
5. Renesas Electronics products are classified according to the following two quality grades: "Standard" and "High Quality". The recommended applications for each Renesas Electronics product depends on the product's quality grade, as indicated below.
"Standard": Computers; office equipment; communications equipment; test and measurement equipment; audio and visual equipment; home electronic appliances; machine tools; personal electronic equipment; and industrial robots etc.
"High Quality": Transportation equipment (automobiles, trains, ships, etc.); traffic control systems; anti-disaster systems; anti-crime systems; and safety equipment etc.
Renesas Electronics products are neither intended nor authorized for use in products or systems that may pose a direct threat to human life or bodily injury (artificial life support devices or systems, surgical implantations etc.), or may cause serious property damages (nuclear reactor control systems, military equipment etc.). You must check the quality grade of each Renesas Electronics product before using it in a particular application. You may not use any Renesas Electronics product for any application for which it is not intended. Renesas Electronics shall not be in any way liable for any damages or losses incurred by you or third parties arising from the use of any Renesas Electronics product for which the product is not intended by Renesas Electronics.
6. You should use the Renesas Electronics products described in this document within the range specified by Renesas Electronics, especially with respect to the maximum rating, operating supply voltage range, movement power voltage range, heat radiation characteristics, installation and other product characteristics. Renesas Electronics shall have no liability for malfunctions or damages arising out of the use of Renesas Electronics products beyond such specified ranges.
7. Although Renesas Electronics endeavors to improve the quality and reliability of its products, semiconductor products have specific characteristics such as the occurrence of failure at a certain rate and malfunctions under certain use conditions. Further, Renesas Electronics products are not subject to radiation resistance design. Please be sure to implement safety measures to guard them against the possibility of physical injury, and injury or damage caused by fire in the event of the failure of a Renesas Electronics product, such as safety design for hardware and software including but not limited to redundancy, fire control and malfunction prevention, appropriate treatment for aging degradation or any other appropriate measures. Because the evaluation of microcomputer software alone is very difficult, please evaluate the safety of the final products or systems manufactured by you.
8. Please contact a Renesas Electronics sales office for details as to environmental matters such as the environmental compatibility of each Renesas Electronics product. Please use Renesas Electronics products in compliance with all applicable laws and regulations that regulate the inclusion or use of controlled substances, including without limitation, the EU RoHS Directive. Renesas Electronics assumes no liability for damages or losses occurring as a result of your noncompliance with applicable laws and regulations.
9. Renesas Electronics products and technology may not be used for or incorporated into any products or systems whose manufacture, use, or sale is prohibited under any applicable domestic or foreign laws or regulations. You should not use Renesas Electronics products or technology described in this document for any purpose relating to military applications or use by the military, including but not limited to the development of weapons of mass destruction. When exporting the Renesas Electronics products or technology described in this document, you should comply with the applicable export control laws and regulations and follow the procedures required by such laws and regulations.
10. It is the responsibility of the buyer or distributor of Renesas Electronics products, who distributes, disposes of, or otherwise places the product with a third party, to notify such third party in advance of the contents and conditions set forth in this document, Renesas Electronics assumes no responsibility for any losses incurred by you or third parties as a result of unauthorized use of Renesas Electronics products.
11. This document may not be reproduced or duplicated in any form, in whole or in part, without prior written consent of Renesas Electronics.
12. Please contact a Renesas Electronics sales office if you have any questions regarding the information contained in this document or Renesas Electronics products, or if you have any other inquiries.

(Note 1) "Renesas Electronics" as used in this document means Renesas Electronics Corporation and also includes its majority-owned subsidiaries.

(Note 2) "Renesas Electronics product(s)" means any product developed or manufactured by or for Renesas Electronics.



SALES OFFICES

Renesas Electronics Corporation

<http://www.renesas.com>

Refer to "<http://www.renesas.com/>" for the latest and detailed information.

Renesas Electronics America Inc.
2880 Scott Boulevard Santa Clara, CA 95050-2554, U.S.A.
Tel: +1-408-588-6000, Fax: +1-408-588-6130

Renesas Electronics Canada Limited
1101 Nicholson Road, Newmarket, Ontario L3Y 9C3, Canada
Tel: +1-905-898-5441, Fax: +1-905-898-3220

Renesas Electronics Europe Limited
Dukes Meadow, Millboard Road, Bourne End, Buckinghamshire, SL8 5FH, U.K
Tel: +44-1628-651-700, Fax: +44-1628-651-804

Renesas Electronics Europe GmbH
Arcadiastrasse 10, 40472 Düsseldorf, Germany
Tel: +49-211-65030, Fax: +49-211-6503-1327

Renesas Electronics (China) Co., Ltd.
7th Floor, Quantum Plaza, No.27 ZhiChunLu Haidian District, Beijing 100083, P.R.China
Tel: +86-10-8235-1155, Fax: +86-10-8235-7679

Renesas Electronics (Shanghai) Co., Ltd.
Unit 204, 205, AZIA Center, No.1233 Lujiazui Ring Rd., Pudong District, Shanghai 200120, China
Tel: +86-21-5877-1818, Fax: +86-21-6887-7858 / -7898

Renesas Electronics Hong Kong Limited
Unit 1601-1613, 16/F., Tower 2, Grand Century Place, 193 Prince Edward Road West, Mongkok, Kowloon, Hong Kong
Tel: +852-2886-9318, Fax: +852 2886-9022/9044

Renesas Electronics Taiwan Co., Ltd.
13F, No. 363, Fu Shing North Road, Taipei, Taiwan
Tel: +886-2-8175-9600, Fax: +886 2-8175-9670

Renesas Electronics Singapore Pte. Ltd.
80 Bendemeer Road, Unit #06-02 Hyflux Innovation Centre Singapore 339949
Tel: +65-6213-0200, Fax: +65-6213-0300

Renesas Electronics Malaysia Sdn.Bhd.
Unit 906, Block B, Menara Amcorp, Amcorp Trade Centre, No. 18, Jln Persiaran Barat, 46050 Petaling Jaya, Selangor Darul Ehsan, Malaysia
Tel: +60-3-7955-9390, Fax: +60-3-7955-9510

Renesas Electronics Korea Co., Ltd.
11F., Samik Lavied' or Bldg., 720-2 Yeoksam-Dong, Kangnam-Ku, Seoul 135-080, Korea
Tel: +82-2-558-3737, Fax: +82-2-558-5141