

NOTES:

1. Ⓢ REPRESENTS A CRITICAL DIMENSION.
2. MINIMUM PUSHOUT FORCE: 1 LB[4.45N].
3. MAXIMUM ALLOWABLE BOW: .002[.05] INCH/INCH AFTER ASSEMBLY.
4. POST HEIGHT VARIATION BETWEEN ANY TWO PINS: .005[.13].
5. FOR ALL PINS: NO BAND MARKS ALLOWED IN POST AREA.
6. FOR LOCKING CLIPS: .75LB[3.336N] MIN RETENTION.
7. MEASURE AT BEND.
8. MAX PIN ROTATION IN BODY TO BE 2°.

DO NOT SCALE FROM THIS PRINT

SHF-1XX-01-X-D-XX-XX

No OF POSITIONS

-02 THRU -25

OPTION

- LC: LOCKING CLIP (NOT AVAILBLE WITH -RA)
- K: POLYIMIDE FILM (-SM ONLY) (AVAILABLE IN TAPE & REEL ONLY) (USE K-DOT-.256-.375-.005)
- TR: TAPE & REEL

LEAD STYLE

-01:

PLATING SPECIFICATION

- L: 10μ" LIGHT SELECTIVE IN CONTACT AREA, MATTE TIN ON TAIL
- F: 3μ" FLASH SELECTIVE GOLD IN CONTACT AREA, MATTE TIN ON TAIL
- S: 30μ" SELECTIVE GOLD IN CONTACT AREA, MATTE TIN ON TAIL

BODY HEIGHT

- TH: THROUGH HOLE (SEE FIG 1, SHT. 1)
- RA: RIGHT ANGLE (SEE FIG 2, SHT. 2)
- SM: SURFACE MOUNT (SEE FIG 3, SHT. 3)

ROW SPECIFICATION

-D: DOUBLE

FIG 1 (SHF-110-01-X-D-TH-LC SHOWN)

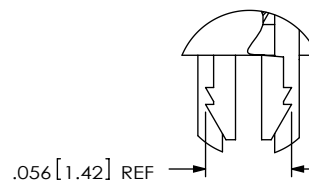
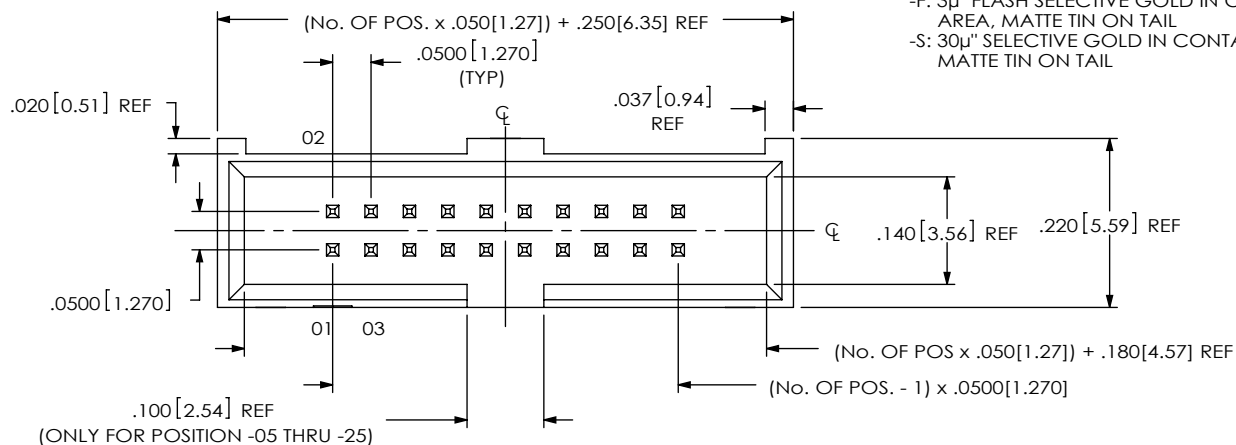

DETAIL 'B' SCALE 8:1

FIRST POSITION INDICATOR

2° MAX SWAY (TYP)

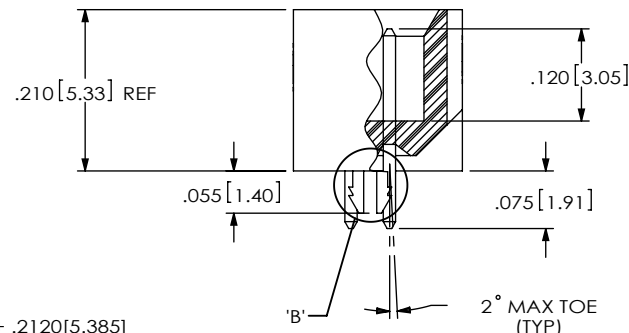
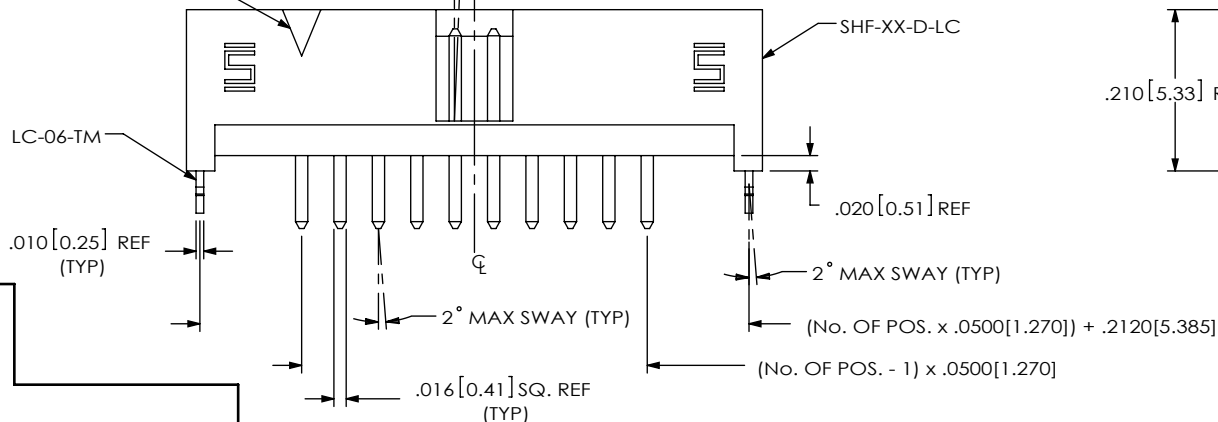

F:\dwg\misc\mktg\SHF-1XX-01-X-D-XX-XX-MKT.LDDRW

IN-PROCESS 1 (FOR -TH ONLY)

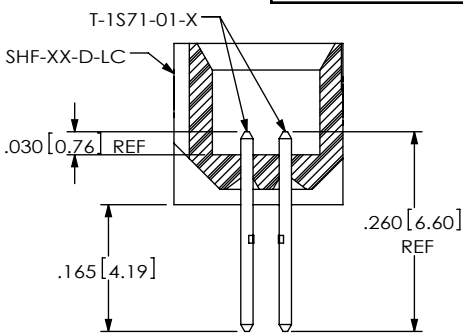

UNLESS OTHERWISE SPECIFIED, DIMENSIONS ARE IN INCHES.
TOLERANCES ARE:
DECIMALS ANGLES
.XX: ±.01 [0.3] 2°
.XXX: ±.005 [0.13]
.XXXX: ±.0020 [0.051]

PROPRIETARY NOTE
THIS DOCUMENT CONTAINS CONFIDENTIAL AND PROPRIETARY INFORMATION AND ALL DESIGN, MANUFACTURING, REPRODUCTION, USE, PATENT RIGHTS AND SALES RIGHTS ARE EXPRESSLY RESERVED BY SAMTEC, INC. THIS DOCUMENT SHALL NOT BE DISCLOSED, IN WHOLE OR PART, TO ANY UNAUTHORIZED PERSON OR ENTITY NOR REPRODUCED, TRANSFERRED OR INCORPORATED IN ANY OTHER PROJECT IN ANY MANNER WITHOUT THE EXPRESS WRITTEN CONSENT OF SAMTEC, INC.



520 PARK EAST BLVD, NEW ALBANY, IN 47150
PHONE: 812-944-6733 FAX: 812-948-5047
e-Mail: info@SAMTEC.com code 55322

MATERIAL: DO NOT SCALE DRAWING SHEET SCALE: 4:1
INSULATOR: SUMIKA E6810LHF, UL 94 VO, COLOR: BLACK
TERMINAL: PHOS BRONZE

DESCRIPTION:
.050 x .050 SHROUDED TERMINAL STRIP

DWG. NO. SHF-1XX-01-X-D-XX-XX

BY: T NEWTON 1/10/2008 SHEET 1 OF 4

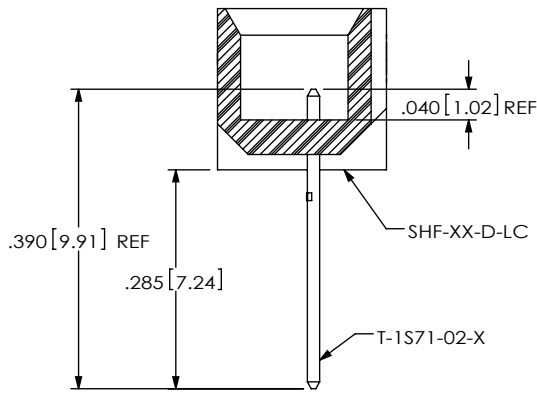

IN-PROCESS 1
(FOR -RA ONLY)

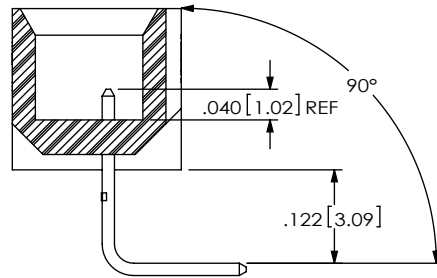

IN-PROCESS 2
(FOR -RA ONLY)

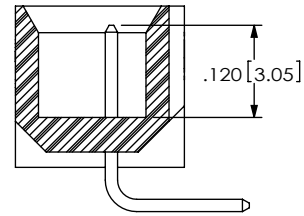

IN-PROCESS 3
(FOR -RA ONLY)

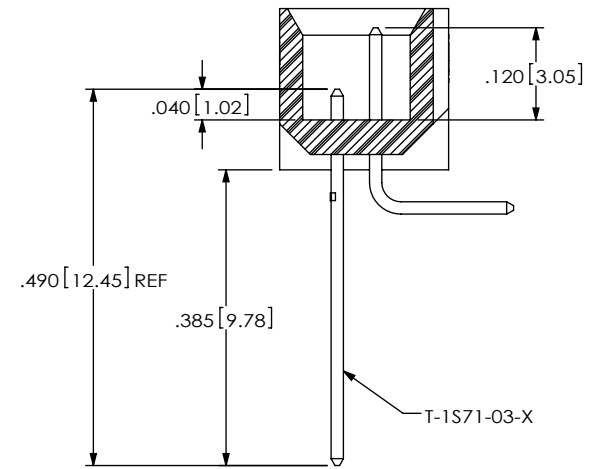

IN-PROCESS 4
(FOR -RA ONLY)

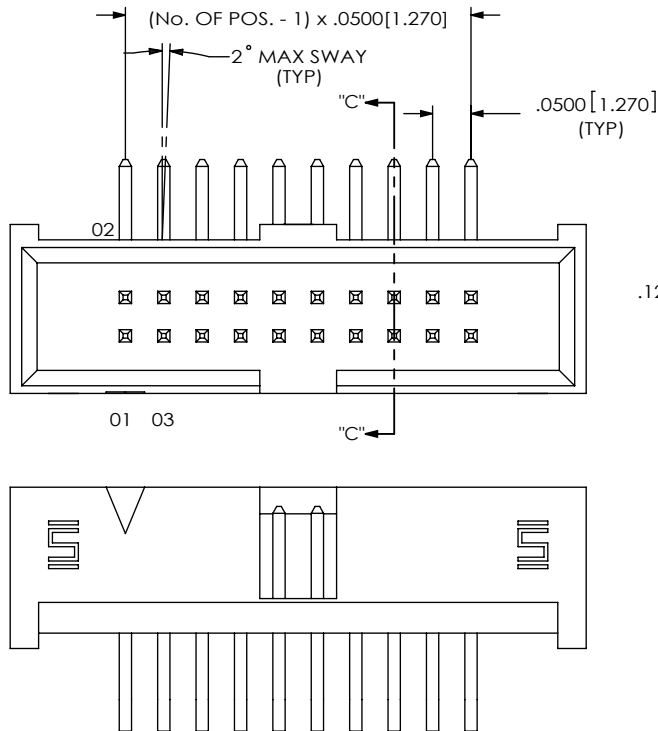
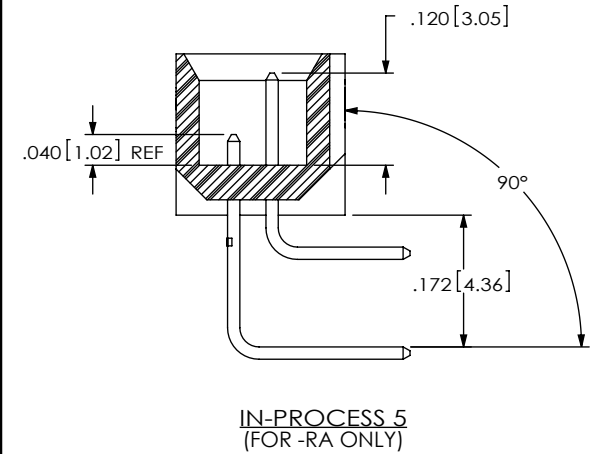
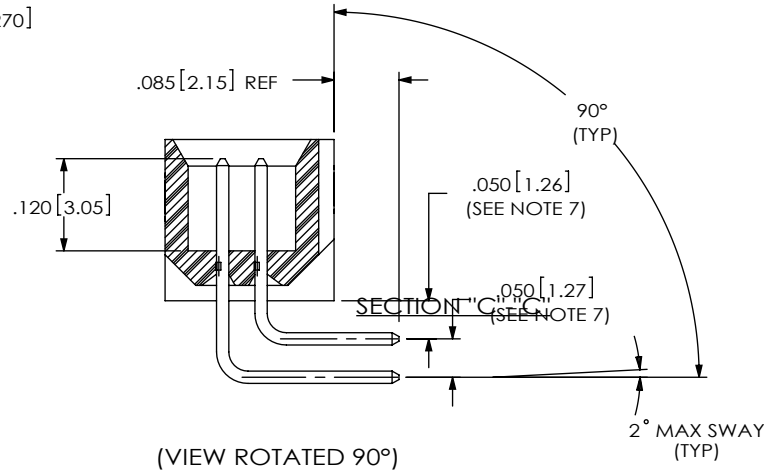

FIG 2
(SHF-110-01-X-D-RA SHOWN)
(SAME AS FIG 1, DIFFERENT AS SHOWN)



IN-PROCESS 5
(FOR -RA ONLY)

F:\dwg\misc\mktg\SHF-1XX-01-X-D-XX-XX-MKT.SLDDRW

PROPRIETARY NOTE
THIS DOCUMENT CONTAINS CONFIDENTIAL AND PROPRIETARY INFORMATION AND ALL DESIGN, MANUFACTURING, REPRODUCTION, USE, PATENT RIGHTS AND SALES RIGHTS ARE EXPRESSLY RESERVED BY SAMTEC, INC. THIS DOCUMENT SHALL NOT BE DISCLOSED, IN WHOLE OR PART, TO ANY UNAUTHORIZED PERSON OR ENTITY NOR REPRODUCED, TRANSFERRED OR INCORPORATED IN ANY OTHER PROJECT IN ANY MANNER WITHOUT THE EXPRESS WRITTEN CONSENT OF SAMTEC, INC.

DO NOT SCALE DRAWING

SHEET SCALE: 4:1



520 PARK EAST BLVD, NEW ALBANY, IN 47150
PHONE: 812-944-6733 FAX: 812-948-5047
e-Mail: info@SAMTEC.com code 55322

DESCRIPTION:
.050 x .050 SHROUDED TERMINAL STRIP

DWG. NO.

SHF-1XX-01-X-D-XX-XX

BY: T NEWTON 1/10/2008

SHEET 2 OF 4

REVISION R

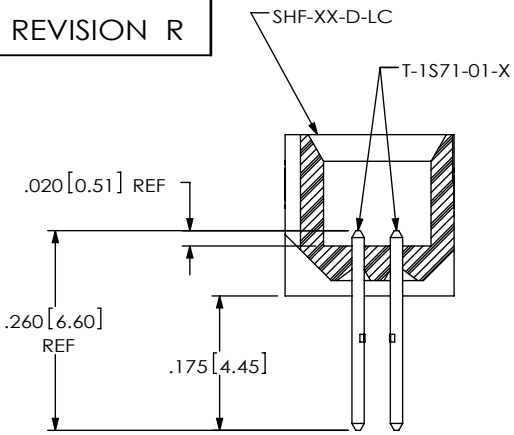

IN-PROCESS 1
(FOR -SM ONLY)

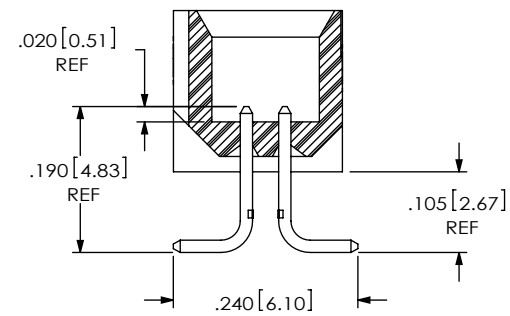

IN-PROCESS 2
(FOR -SM ONLY)

FIG 3
(SHF-110-01-X-D-SM-LC SHOWN)
(SAME AS FIG 1, DIFFERENT AS SHOWN)

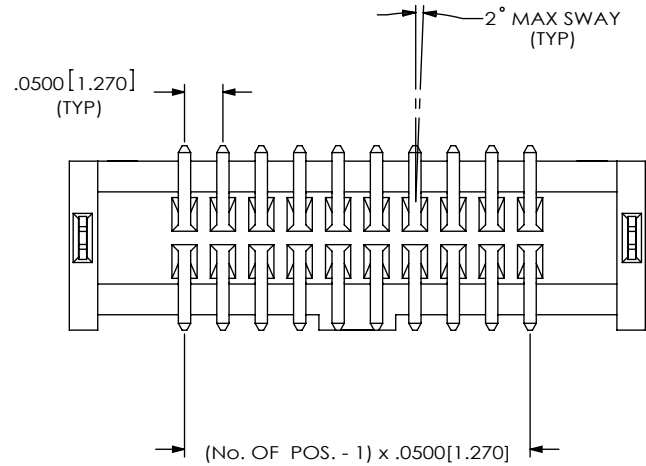
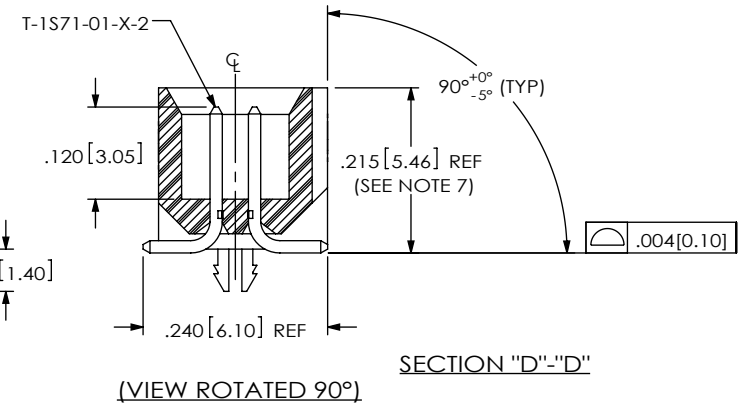
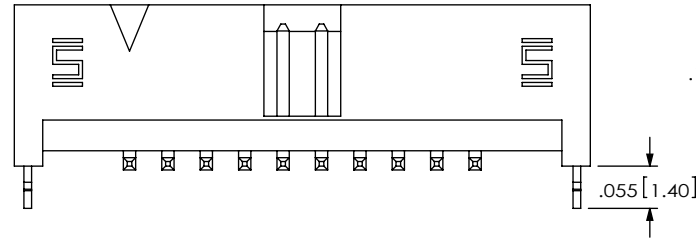
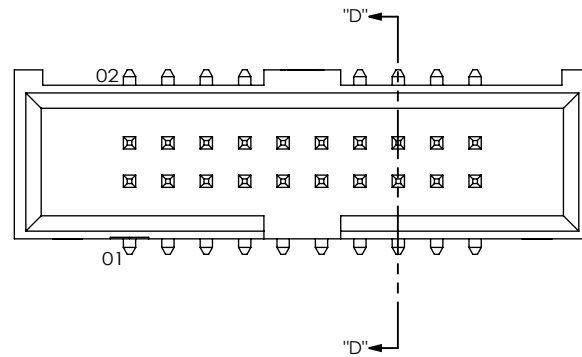

F:\dwg\misc\mktg\SHF-1XX-01-X-D-XX-XX-MKT.SLDDRW

PROPRIETARY NOTE
THIS DOCUMENT CONTAINS CONFIDENTIAL AND PROPRIETARY INFORMATION AND ALL DESIGN, MANUFACTURING, REPRODUCTION, USE, PATENT RIGHTS AND SALES RIGHTS ARE EXPRESSLY RESERVED BY SAMTEC, INC. THIS DOCUMENT SHALL NOT BE DISCLOSED, IN WHOLE OR PART, TO ANY UNAUTHORIZED PERSON OR ENTITY NOR REPRODUCED, TRANSFERRED OR INCORPORATED IN ANY OTHER PROJECT IN ANY MANNER WITHOUT THE EXPRESS WRITTEN CONSENT OF SAMTEC, INC.

DO NOT SCALE DRAWING

SHEET SCALE: 4:1

samtec

520 PARK EAST BLVD, NEW ALBANY, IN 47150
PHONE: 812-944-6733 FAX: 812-948-5047
e-Mail: info@SAMTEC.com code 55322

DESCRIPTION:
.050 x .050 SHROUDED TERMINAL STRIP

DWG. NO.
SHF-1XX-01-X-D-XX-XX

BY: T NEWTON 1/10/2008 SHEET 3 OF 4

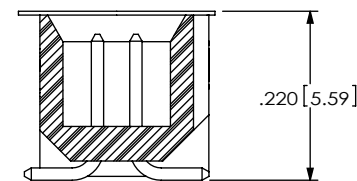
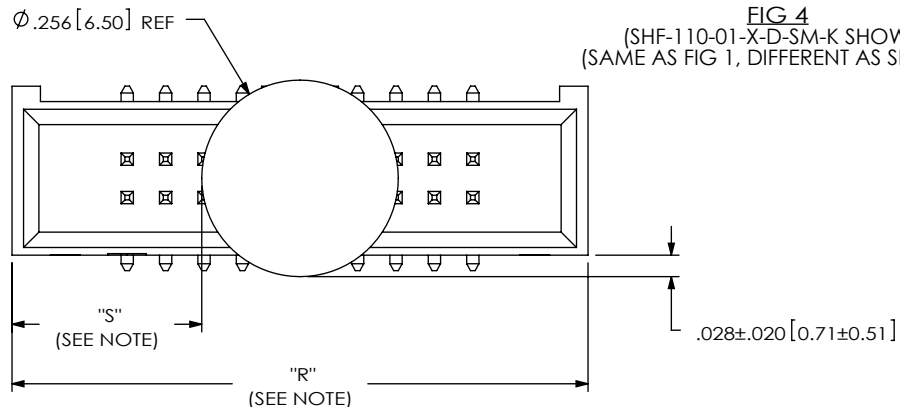

(VIEW ROTATED 90°)

NOTE: "R" = USED MEASURED DIMENSION (REF)
 "S" = $\{("R" - .256[6.50])/2\} \pm 0.020[0.51]$

PACKAGING
 ALL PARTS ARE LOADED WITH POSITION 1
 TOWARD THE ARROW "EXCEPT -RA"

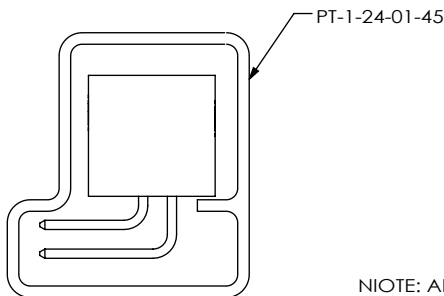
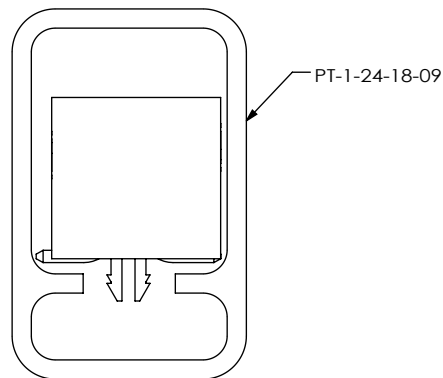
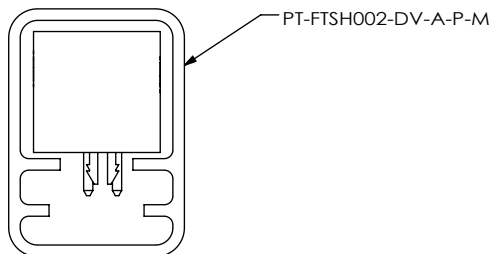

NOTE: ALL POSITIONS ARE TO BE TUBED

OPTIONS	PACKAGING TUBE	PLUG
-TH, -TH-LC	PT-FTSH002-DV-A-P-M	TP-03
-SM-LC	PT-1-24-18-09	TP-03
-RA	PT-1-24-01-45	TP-07
-SM	PT-1-24-18-09	TP-03

**CRITICAL DIMENSION INSPECTION
 INSTRUCTION TABLE**

ASSEMBLY OPERATION	IN-PROCESS INSPECTION
(-TH) FILL T-1S71-01-X	C1, C2, C3, C6, C7, C8, C10, C30, C31
(-TH) REPRESS T-1S71-01-X	C11
(-RA) FILL T-1S71-02-X	C1, C2, C3, C7, C8, C12, C13
(-RA) RA T-1S71-02-X	C32, C33,
(-RA) REPRESS T-1S71-02-X	C34
(-RA) FILL T-1S71-03-X	C6, C7, C8, C10, C14, C15
(-RA) RA T-1S71-03-X	C35, C36
(-RA) REPRESS T-1S71-03-X	C16, C17, C18, C19, C20, C37
(-SM) FILL T-1S71-01-X	C1, C2, C3, C6, C7, C21, C22
(-SM) REPRESS T-1S71-01-X	C23, C24, C26, C38
INSTALL KAPTON	C27, C28
INSTALL LC-06-TM	C9, C29
CPC'S INTENTIONALLY DELETED: C4, C5	

PROPRIETARY NOTE
 THIS DOCUMENT CONTAINS CONFIDENTIAL AND PROPRIETARY INFORMATION AND ALL DESIGN, MANUFACTURING, REPRODUCTION, USE, PATENT RIGHTS AND SALES RIGHTS ARE EXPRESSLY RESERVED BY SAMTEC, INC. THIS DOCUMENT SHALL NOT BE DISCLOSED, IN WHOLE OR PART, TO ANY UNAUTHORIZED PERSON OR ENTITY NOR REPRODUCED, TRANSFERRED OR INCORPORATED IN ANY OTHER PROJECT IN ANY MANNER WITHOUT THE EXPRESS WRITTEN CONSENT OF SAMTEC, INC.

DO NOT SCALE DRAWING

SHEET SCALE: 4:1



520 PARK EAST BLVD, NEW ALBANY, IN 47150
 PHONE: 812-944-6733 FAX: 812-948-5047
 e-Mail info@SAMTEC.com code 55322

DESCRIPTION:
 .050 x .050 SHROUDED TERMINAL STRIP

DWG. NO. SHF-1XX-01-X-D-XX-XX

BY: T NEWTON 1/10/2008 SHEET 4 OF 4