

THIS DRAWING IS UNPUBLISHED. RELEASED FOR PUBLICATION
 © COPYRIGHT - BY TYCO ELECTRONICS CORPORATION. ALL RIGHTS RESERVED.

LOC	DIST	REVISIONS					
		P	LTR	DESCRIPTION	DATE	DWN	APVD
AF	50		A2	REL PER ECR 06-029769	20DEC06	JR	KR

- 1 CONTINUOUS STRIP ON REELS
- 2 WIRE SIZE 1200-3000 CMA
- 3 CRIMP INFO: WIDTH .110, F TYPE
 CRIMP HT ($\pm .002$) = $(\text{TOTAL CMA} + 10,875)/187,500$

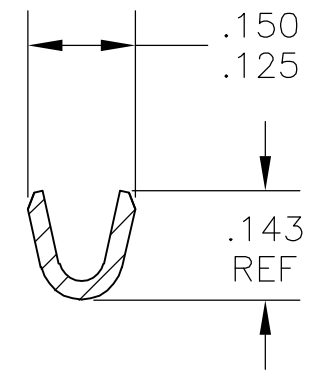
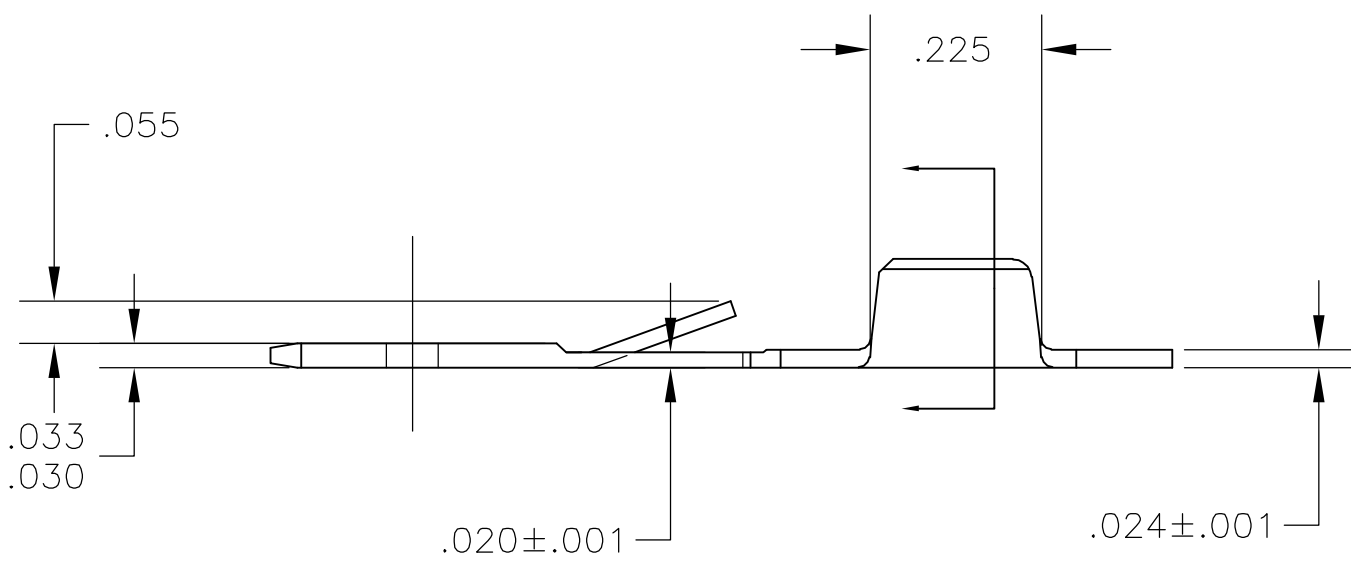
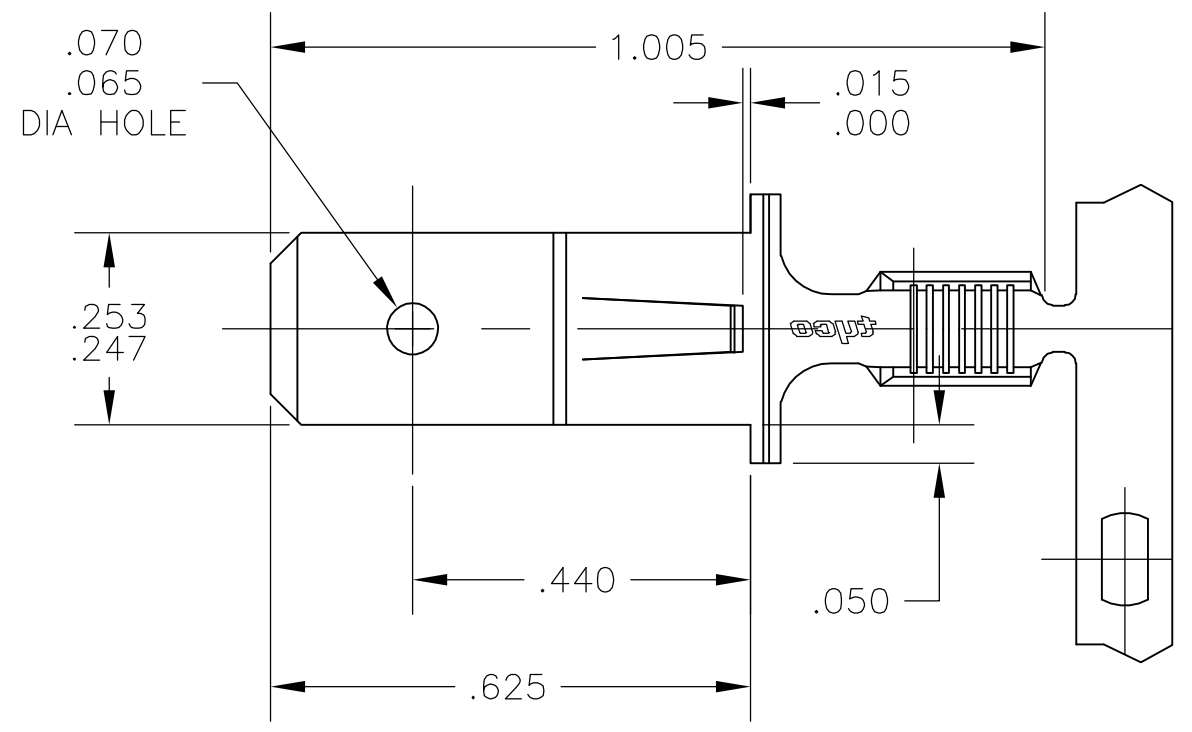

1742425-1
 PART NO

THIS DRAWING IS A CONTROLLED DOCUMENT.		DWN jr_ruth 31MAR06	Tyco Electronics Corporation Harrisburg, Pa 17105-3608						
DIMENSIONS: INCHES 		CHK K RANDOLPH 31MAR06							
TOLERANCES UNLESS OTHERWISE SPECIFIED: 0 PLC ± - 1 PLC ± - 2 PLC ± - 3 PLC ± .010 4 PLC ± - ANGLES ± 5°		APVD K RANDOLPH 31MAR06	NAME TAB, FASTIN-FASTON, AMPLIVAR, .250 SERIES						
MATERIAL 082 BRASS		FINISH .000080 MIN TIN	PRODUCT SPEC -	APPLICATION SPEC 114-2146	RESTRICTED TO -				
CUSTOMER DRAWING			WEIGHT -	SIZE A3	CAGE CODE 00779	DRAWING NO 1742425	SCALE 4:1	SHEET 1 OF 1	REV A2