

**WHEN ORDERING CONTACT ON TAPE, ORDER BY THE TAPE NUMBER PLUS THE PACKAGING CODE AS FOLLOWS:**

1. FOR USE WITH AMP TAPETRONIC, PNEUMATIC TOOL-
  - A. 1000 PARTS TO A BOX ADD PACKAGING CODE: 1MBOX
2. FOR USE WITH 4/8 INDENT STRIPPER CRIMPER-
  - A. 1000 PARTS TO A REEL ADD PACKAGING CODE: 1MREEL
  - B. 5000 PARTS TO A REEL ADD PACKAGING CODE: 5MREEL

- (-1) 1. AS SHOWN.
- (-2) 1. SAME AS -1 EXCEPT:  
2. FINISH: ITEM 1: .0001 MIN. AVE SILVER OVER .00003 MIN. NICKEL.
- OBSOLETE (-3) 1. SAME AS -1 EXCEPT:  
2. FINISH ITEM 1: .000015 MIN. GOLD OVER .00005 MIN. NICKEL.
- (-4) 1. SAME AS -1 EXCEPT:  
2. FINISH ITEM 1: .00003 MIN. GOLD OVER .00003 MIN. NICKEL.
- OBSOLETE (-5) 1. SAME AS -1 EXCEPT:  
2. MOUNTED ON TAPE.
- OBSOLETE (-6) 1. SAME AS -4 EXCEPT:  
2. MOUNTED ON TAPE.

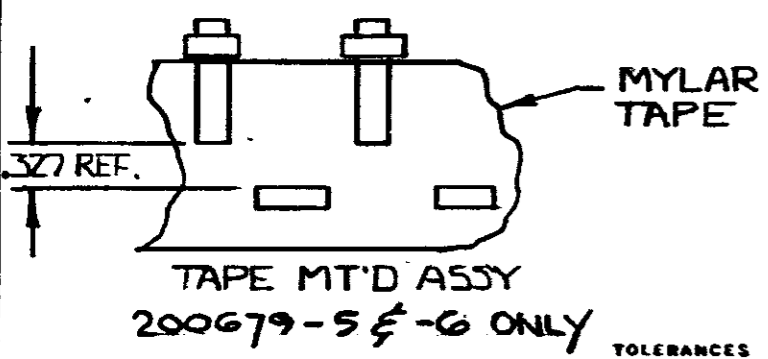
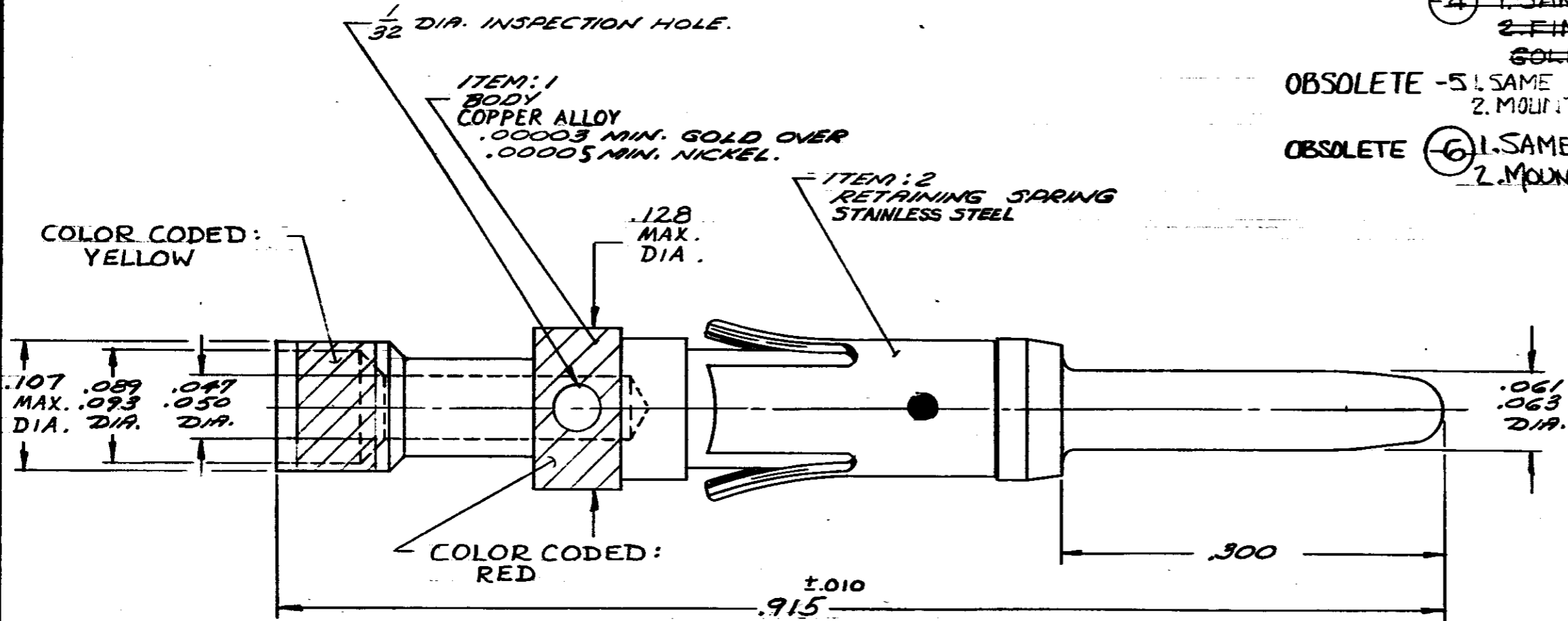

TOLERANCES EXCEPT AS NOTED:  
 DECIMALS: ± .008  
 FRACTIONS: ± 1/64  
 ANGLES: ± 12°

REV	DESCRIPTION	DATE	CHK	DR
V	OBS -3 PER ECN 802619	10-89	CS	J.S.
U	OBSOLETE -5 BD3036	9-89	SW	J.S.
T	REV PER ECN 802619	3-89	THW	J.S.
S	OBS -6 / 54623	5-87	MMH	THW
LTR	REVISION RECORD		DR	CHK

NUMBER	DESCRIPTION	REQUIRED PER ASSEMBLY
200679		

©1967 BY AMP INCORPORATED. ALL RIGHTS RESERVED. AMP PRODUCTS COVERED BY PATENTS AND/OR PATENTS PENDING.		CUSTOMER COPY REFERENCE ONLY	
DR P. Owen 2-24-61	MATERIAL AND FINISH SEE CALL OUT	AMP INCORPORATED - HARRISBURG, PENNA.	
CHK [Signature] 2-27-61	WIRE - RANGE - INSULATION 24-20 - H	CLASS SPECIAL SHORT	
DE [Signature] 2-28-61	TOLERANCE - EXCEPT AS NOTED ± .015 - ± .001	TYPE II	NO 200679
APP [Signature] 2-28-61	NAME #16 CONTACT - PIN	LOC BD	NO B

DIMENSIONS IN INCHES. DO NOT SCALE PRINT.

39 M 10

CUSTOMER DRAWING