

DESCRIPTION: HIGH DENSITY FEMALE - VERTICAL DIP SOLDER

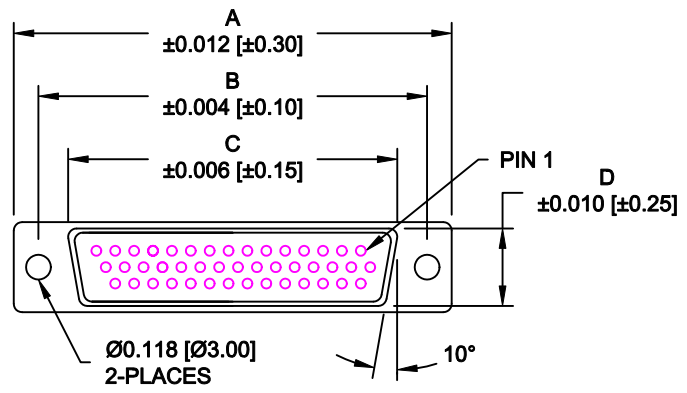

No. OF PINS	DIMENSIONS							
	A	B	C	D	E	F	G	G
15	1.213	0.984	0.643	0.311	0.090	0.756	0.496	0.429
	30.80	24.99	16.34	7.90	2.29	19.20	12.60	10.90
26	1.541	1.312	0.966	0.311	0.090	1.091	0.496	0.429
	39.15	33.32	24.53	7.90	2.29	27.70	12.60	10.90
44	2.087	1.852	1.512	0.311	0.090	1.618	0.496	0.429
	53.00	47.04	38.40	7.90	2.29	41.10	12.60	10.90
62	2.728	2.500	2.155	0.311	0.095	2.256	0.496	0.429
	69.30	63.50	54.76	7.90	2.41	57.30	12.60	10.90
78	2.638	2.406	2.057	0.429	0.095	2.169	0.606	0.526
	67.00	61.10	52.26	10.90	2.41	55.10	15.40	13.35

4 ROWS

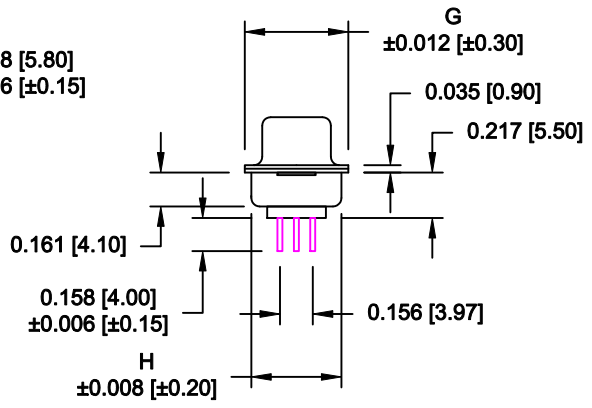
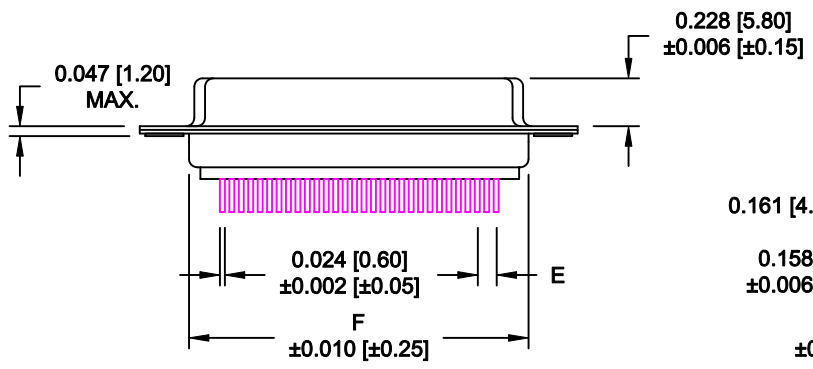

180-YYY-213RYY1

- SERIES _____
- POSITIONS _____
- 015 _____
- 026 _____
- 044 _____
- 062 _____
- 078 _____
- GENDER _____
- 2 = FEMALE
- TERMINATION _____
- 1 = VERTICAL DIP SOLDER
- SHELL PLATING _____
- 2 = TIN
- 3 = NICKEL
- RoHS COMPLIANT (260°C) _____
- HARDWARE OPTIONS _____
- 00 = NO HARDWARE
- 01 = .098" CLINCH NUT (BOARD SIDE)
- 02 = .236" CLINCH NUT (BOARD SIDE)
- 03 = .236" CLINCH NUT (MATING SIDE)
- 05 = .237" 4-40 BOARD LOCK
- 08 = .224" 4-40 BOARD LOCK
- 90 = .237" 4-40 BOARD LOCK
- FOR 0.093" BOARD MAX.
- 91 = .237" 4-40 SPACER/BOARD LOCK
- 92 = .237" 4-40 SPACER/BOARD LOCK
- FOR 0.093" BOARD MAX.
- PLATING OPTIONS _____
- 1 = GOLD FLASH
- 2 = 30u" GOLD

MATERIAL:

- SHELL: STEEL, NICKEL PLATED
- INSULATOR: PBT, UL 94V-O RATED, +30% FIBER-GLASS OR NYLON-66
- CONTACT: BRASS, GOLD PLATED OVER NICKEL

ELECTRICAL:

- CURRENT RATING: 5 AMPS
- CONTACT RESISTANCE: 15 mOhms Max.
- INSULATION RESISTANCE: 1,000 MOhms min.
- VOLTAGE: 500VAC FOR 1 MINUTE
- TEMPERATURE: -50° C TO 100° C

DO NOT SCALE FROM DRAWING

RoHS COMPLIANT

	THESE DRAWINGS AND SPECIFICATIONS ARE THE PROPERTY OF NorComp AND SHALL NOT BE REPRODUCED, COPIED OR USED AS THE BASIS FOR THE MANUFACTURE OF SALE OF APPARATUS WITHOUT WRITTEN PERMISSION.		DRAWN: PAM JENKINS	DATE: 09-12-05
			CHECKED:	DATE:
NorComp		SCALE: 1 : 1	SHEET 1 OF 3	REV 15
		DWG NO. 180-YYY-213RYY1		

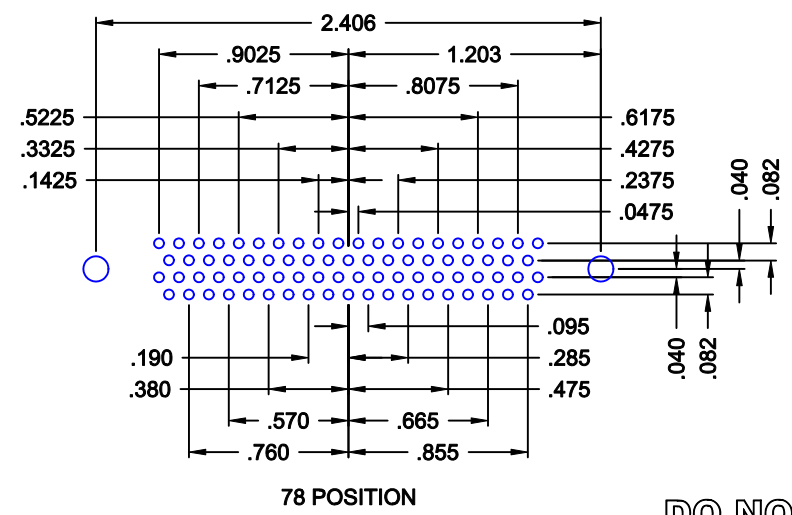
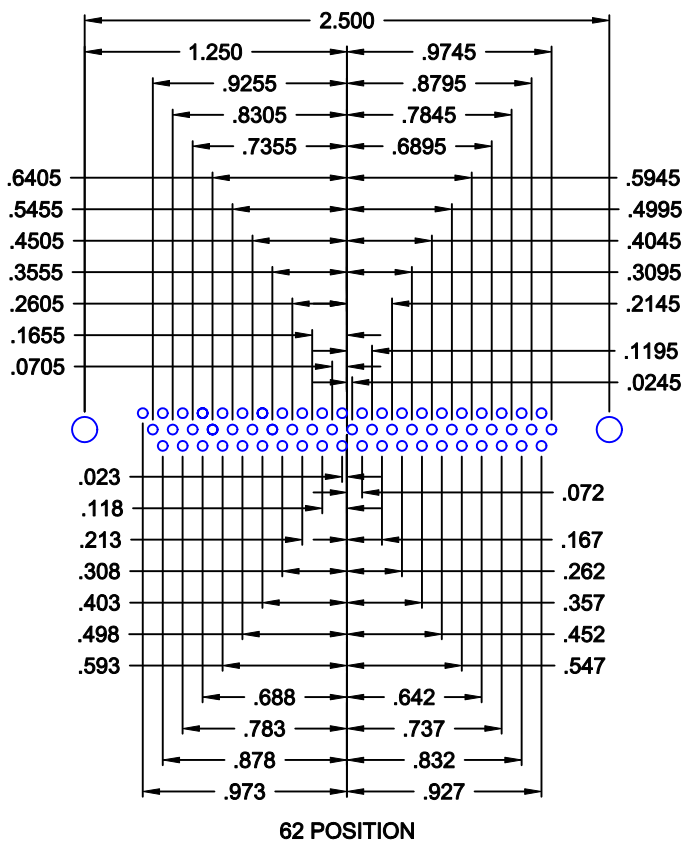
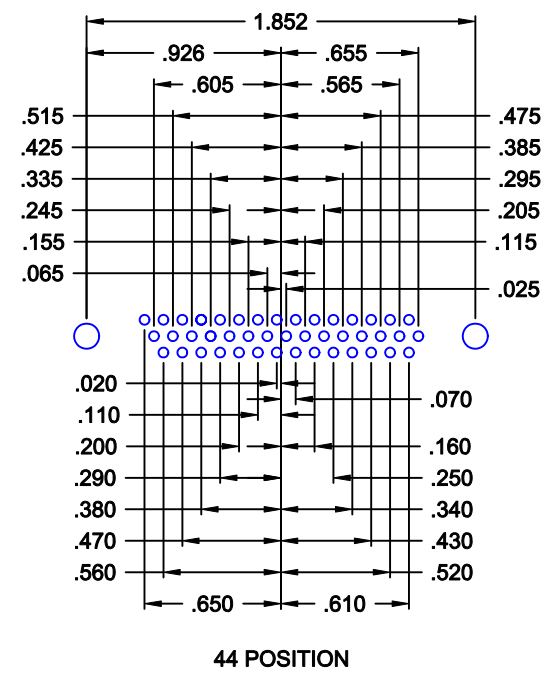
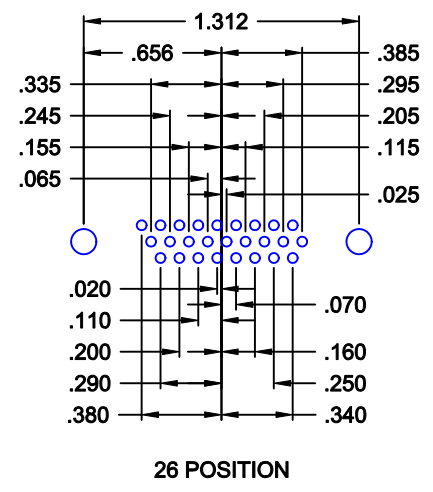
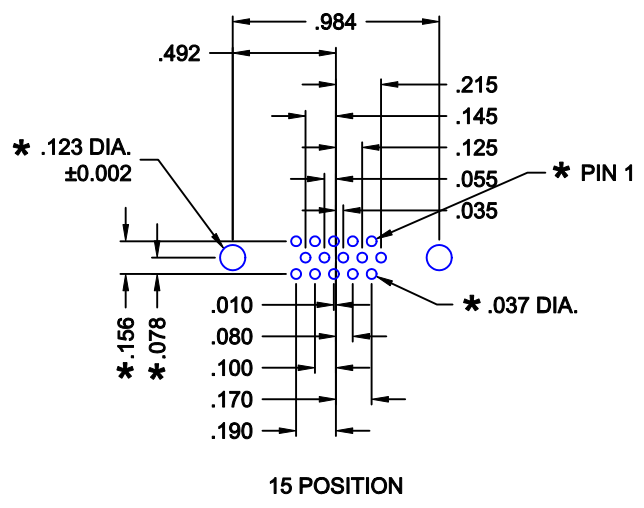

**180 SERIES
HIGH DENSITY
VERTICAL**

**HOLE PATTERN SHOWN
ARE FOR FEMALE**

*** TYP. ON ALL SIZES**

DO NOT SCALE FROM DRAWING

	THESE DRAWINGS AND SPECIFICATIONS ARE THE PROPERTY OF NorComp AND SHALL NOT BE REPRODUCED, COPIED OR USED AS THE BASIS FOR THE MANUFACTURE OF SALE OF APPARATUS WITHOUT WRITTEN PERMISSION.		DRAWN: PAM JENKINS	DATE: 09-12-05
			CHECKED:	DATE:
NorComp	SCALE:	SHEET 2 OF 3	REV 15	
	DWG NO. 180-YYY-213RYY1			

ALL CLINCH-NUTS ARE 4-40 INTERNAL THREADS

TOLERANCE:
ALL DIMENSIONS ARE ±0.010

01X 0.098" (BOARD SIDE) - CN1

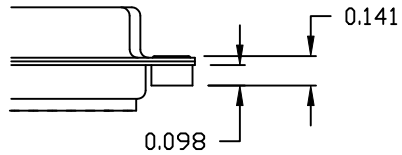

02X 0.236" (BOARD SIDE) - CN2

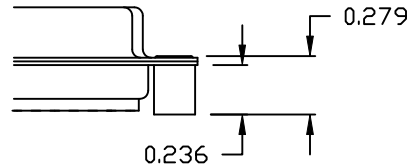

03X..... 0.236" (MATING SIDE) - CN8

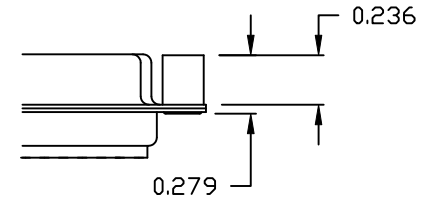

05X 0.237" (BOARD SIDE) - CN10

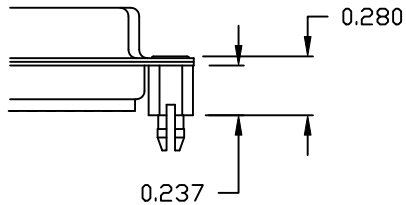

08X 0.228" (BOARD SIDE) - CN3

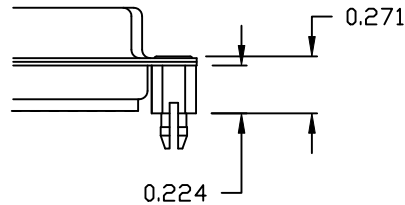

91X 0.237" BOARD SIDE
0.197 MATING SIDE
CN10/SFSO4404

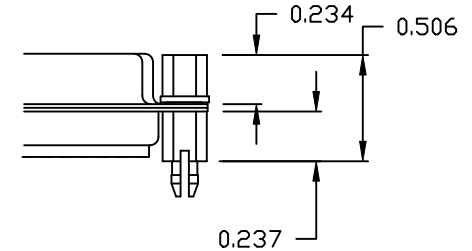

NOTE: 4-40 FEMALE SCREW LOCK IS REMOVABLE

90X 0.237" (BOARD SIDE) - CN10-237-093

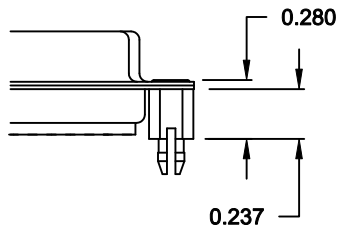

92X 0.237" BOARD SIDE
0.197 MATING SIDE
CN10-237-093/SFSO4404

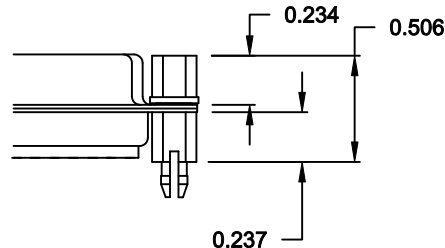

NOTE: 4-40 FEMALE SCREW LOCK IS REMOVABLE

NOTE: 90 & 92 OPTION FOR 0.093" MAX. BOARD THICKNESS

DO NOT SCALE FROM DRAWING

RoHS COMPLIANT

	THESE DRAWINGS AND SPECIFICATIONS ARE THE PROPERTY OF NorComp AND SHALL NOT BE REPRODUCED, COPIED OR USED AS THE BASIS FOR THE MANUFACTURE OF SALE OF APPARATUS WITHOUT WRITTEN PERMISSION.		DRAWN: WAYNE ROBBINS	DATE: 11-28-05	
			CHECKED:	DATE:	
<h1>NorComp</h1>			SCALE:	SHEET 3 OF 3	REV 15
			DWG NO. 180-YYY-213RYY1		