

ATLANTIC VERSION TERMINATOR INTERFACE ADAPTER	PART NUMBER	REVISION	DESCRIPTION	FEED TYPE	APPLICATOR STYLE CONVERSION CHART						
					CONVERT TO	PART NUMBERS REQUIRED					
	2151643-1	A	FINE CRIMP HEIGHT ADJUST	MECHANICAL	PNEUMATIC FEED	2119950-1	1338683-3	5-18022-5	2119641-1	2119799-1	2063440-1
					SERVO LATCH PLATE	2119951-1	-	8-2151643-5	1901094-3	-	2168400-6 (QUANTITY 2)
					SMART APPLICATOR	2161326-1	-	8-2151643-4	-	-	-
	2151643-2	A	FINE CRIMP HEIGHT ADJUST	PNEUMATIC	MECHANICAL FEED	2119949-1	1338683-3	5-18022-5	2119653-1	-	-
					SERVO LATCH PLATE	2119951-1	-	8-2151643-5	1901094-3	-	2168400-6 (QUANTITY 2)
					SMART APPLICATOR	2161326-1	-	8-2151643-4	-	-	-
	2151643-5	A	FINE CRIMP HEIGHT ADJUST	SERVO LATCH PLATE ⁴	MECHANICAL FEED	2119949-1	1338683-3	5-18022-5	2119653-1	-	-
					PNEUMATIC FEED	2119950-1	1338683-3	5-18022-5	2119641-1	2119799-1	2063440-1
	2151643-6	A	NON-CRIMP HEIGHT ADJUST	SERVO LATCH PLATE ⁴	-	-	-	-	-	-	-
					-	-	-	-	-	-	-
	2151643-7	A	FINE CRIMP HEIGHT ADJUST	NONE	-	-	-	-	-	-	-
7-2151643-7	A	CRIMP TOOLING KIT	-	-	-	-	-	-	-	-	

APPLICATOR DATA		
CRIMP WIRE	SIZE	TYPE
	2.92 mm [.115]	F
INSUL	3.81 mm [.150]	F

APPLICATOR INSTRUCTIONS 408-10389

TERMINAL DATA: DELPHI PACKARD TERMINAL & SPECIFICATION			
TERMINAL NAME: RING			
WIRE STRIP LENGTH		INSULATION DIAMETER RANGE	
6.70-7.50 mm [.264-.295 IN]		Ø2.03-2.40 mm [.080-.094 IN]	
TERMINAL APPLICATION SPECIFICATION	02989521 Rev -	-	-
TERMINALS APPLIED			
TE TERMINAL	DELPHI PACKARD TERMINAL	TE TERMINAL	DELPHI PACKARD TERMINAL
2113266-1	02989521		

WIRE SIZE	CRIMP HEIGHT mm [INCH]	CRIMP HEIGHT REFERENCE SETTING
0.80mm2	2.20+/-0.05 [.087+/- .002]	11.2
0.50mm2	2.15+/-0.05 [.085+/- .002]	12.0

- RECOMMENDED SPARE PARTS
- GREASE BEARING SURFACES LIGHTLY
- 3. LUBRICATE DAILY PER THE APPLICATOR INSTRUCTION SHEET SUPPLIED WITH THE APPLICATOR.
- APPLICATOR SPECIFIC DATA TO BE ENTERED INTO BLANK MEMORY CHIP AT ASSEMBLY. SEE BELOW FOR PART NUMBER:
 MECHANICAL FEED WITH "SMART APPLICATOR" CONVERSION: 8-2151643-4
 PNEUMATIC FEED WITH "SMART APPLICATOR" CONVERSION: 8-2151643-4
 SERVO FEED WITH "FINE CRIMP HEIGHT ADJUST": 8-2151643-5
 SERVO FEED WITH "NON-CRIMP HEIGHT ADJUST": 8-2151643-6
- 5. ADJUSTMENT OF THE STRIPPER MAY BE REQUIRED WHEN MOVING THE APPLICATOR BETWEEN BENCH AND LEADMAKER APPLICATIONS.
- APPLY PART NUMBER 1-23419-5 LOCTITE TO THREADS OF ITEM 50.
- GREASE THREADS, GROOVE AND O-RING ON ITEMS 35 & 252.
- MAGNET, ITEM 166 MUST BE ORIENTED CORRECTLY IN ORDER TO PROPERLY ACTUATE THE COUNTER.
- CRIMP HEIGHT REFERENCE SETTING WAS THE SETTING USED WHEN THE APPLICATOR WAS QUALIFIED AT THE FACTORY. ADJUSTMENT MAY BE NECESSARY WHEN RUNNING APPLICATOR IN THE FIELD.
- SPARE FEED CAM STORAGE LOCATION REFER TO INSTRUCTION SHEET FOR ADDITIONAL INFORMATION.
- WHEN ASSEMBLING -6 NON-CRIMP HEIGHT ADJUST APPLICATOR USE SHIM PACK 2119957-2 TO ALIGN APPLICATOR'S MAXIMUM WIRE CRIMP HEIGHT AT NORMAL TERMINATOR SHUT HEIGHT

***WARNING**
 ON INSTALLATION, SET WIRE DISC, ITEM 40 TO LARGEST WIRE SIZE SETTING. USE OF SETTINGS BELOW MINIMUM REQUIRED CRIMP HEIGHT SETTING WILL CAUSE DAMAGE TO CRIMP TOOLING.

-	1	1	1	1	1	3-18031-6	SCR, SET, CUP POINT M2.5 X 3.0	266
-	2	2	2	2	2	2168083-2	SCR, SKT HD CAP, RoHS, M4 X 8.0	265
-	1	1	1	1	1	1-1583859-9	BLADE, SLUG	264
-	1	1	1	1	1	1-2168083-0	SCR, SKT HD CAP, RoHS, M4 X 10	263
-	1	1	1	1	1	2119924-4	SHEAR, LOWER	262
-	-	1	-	-	-	2119957-2	APPLICATOR SHIM PACK	260
-	1	-	1	1	1	8-21084-0	O-RING, .676 ID, .070 DIA. MAT.	252
-77	-7	-6	-5	-2	-1	PART NO	DESCRIPTION	ITEM NO

ATLANTIC VERSION
 Shown on sheets 1 of 4 & 2 of 4
 (Pacific version shown on sheets 3 of 4 & 4 of 4)

SET UP GAUGE	LOC	DIST	REVISIONS				
2119599-1	A	66	REV	DATE	BY	APPV	
			A	RELEASED	29AUG2012	RK	TE

-	-	-	-	1	-	2119640-1	PUSH ROD, AIR FEED	250
-	-	-	-	1	-	2079988-1	BUSHING, LCH5-12, MISUMI	249
-	-	-	-	1	-	2119641-1	FEED CAM, AIR FEED	248
-	1	-	1	1	1	2119798-1	DETENT PIN	247
-	1	-	1	1	1	1-22279-3	SPRING, COMPRESSION	246
-	-	1	-	-	-	2119758-1	RAM, AMP STYLE, SIDE FEED, NON-ADJ.	245
-	1	1	1	1	1	2119082-6	CAM, SNAIL, INSULATION ADJUSTMENT	244
-	1	1	1	1	1	2079764-1	WASHER, WAVE SPRING, CREST-TO-CREST	243
-	1	1	1	1	1	2119083-1	RETAINER, INSULATION DIAL	242
-	-	2	2	-	-	2168400-6	SHCS, LOW HEAD, RoHS, M5 X 16	240
-	-	-	-	-	-	2119580-1	MECHANICAL FEED ASSEMBLY	239
-	-	-	-	-	-	2063440-1	AIR FEED MODULE	238
-	-	1	1	-	-	2119740-2	TAG, IDENTIFICATION	213
-	-	1	1	-	-	1901094-3	SPACER, FEEDER	198
-	-	-	-	2	-	21045-3	RING, RETAIN, EXTERN, 3/16 CRESCENT	172
-	1	1	1	1	1	994969-1	MAGNET, RARE EARTH HIGH ENERGY	166
-	REF	REF	REF	REF	REF	994970-2	COUNTER, MAGNETIC	164
-	-	-	-	1	-	240638-1	SPRING, FEED FINGER	163
-	-	-	-	1	-	3-23627-7	PIN, RETAIN, GRVD, 3/16 X .854	137
-	-	-	-	1	-	2119799-1	HOLDER, FEED FINGER, AF	136
-	-	REF	REF	-	-	SEE NOTE 4	MEMORY CHIP, PROGRAMMED	135
-	-	1	1	-	-	1633743-1	SERVO FEED LATCH ASM	133
-	-	REF	REF	-	-	2119944-1	FEED FINGER ASSEMBLY, SF	117
-	1	1	1	1	1	1-690712-0	FRONT STRIP GUIDE	96
-	2	2	2	2	2	1-2168083-3	SCR, SKT HD CAP, RoHS, M3 X 16	95
-	1	1	1	1	1	455888-5	SPACER, CRIMPER	82
-	2	2	2	2	2	2168083-1	SCR, SKT HD CAP, RoHS, M3 X 8.0	79
-	1	1	1	1	1	1633782-4	FENCE	78
-	1	1	1	1	1	2119956-1	DOCUMENTATION PACKAGE	71
-	1	-	-	1	1	2119740-1	TAG, IDENTIFICATION	67
-	2	2	2	2	2	2168078-1	SCREW, DRIVE, RH, RoHS	66
-	1	-	1	1	1	2119793-1	LIMITER, ADJUSTMENT BOLT	63
-	3	-	3	3	3	992763-5	SCR, SET, SOC, CONE POINT, M3 X 4.0	62
-	2	2	2	2	2	2-18032-5	SCR, SET, FLT POINT M5 X 20.0	61
-	1	1	1	1	1	2079383-4	SCR, BHSC, RoHS (M4 X 8)	60
-	-	-	-	1	1	5-18022-5	SCR, HEX HD CAP, M4 X 6.0	59
-	-	-	-	1	1	1338683-3	FEED PAWL	56
-	2	2	2	2	2	1-18023-7	SCR, SKT HD CAP M4 X 40.0	53
-	1	1	1	1	1	811242-5	BUMPER, HOLD DOWN	51
-	1	1	1	1	1	2119830-7	HOLDER, SLUG BLADE	50
-	-	-	-	1	2	18023-9	SCR, SKT HD CAP M4 X 6.0	49
-	-	-	-	-	1	2119652-1	FEED CAM, PRE FEED	48
-	-	-	-	-	1	2119653-1	FEED CAM, POST FEED	47
-	1	1	1	1	1	2119656-1	APPLICATOR BASIC ASSEMBLY, SF	46
-	1	-	1	1	1	2119370-1	RAM, AMP STYLE, SIDE FEED	44
-	1	1	1	1	1	2079383-7	SCR, BHSC, RoHS (M8 X 25)	41
-	1	-	1	1	1	2119645-1	DISC, NUMBERED FA WIRE ADJUSTMENT	40
-	1	-	1	1	1	2119957-1	APPLICATOR SHIM PACK	39
-	1	1	1	1	1	2119644-3	RAM WASHER, PRECISION	38
-	1	1	1	1	1	2119085-1	FA HEAD, ATLANTIC STYLE	37
-	1	-	1	1	1	2119092-1	BOLT, ADJUSTMENT	35
-	2	2	2	2	2	2079383-5	SCR, BHSC, RoHS (M4 X 20)	33
-	1	1	1	1	1	2161328-1	HEX HEAD, FLANGED, M5 X 8mm LONG	32
-	1	1	1	1	1	1-1320908-6	SPACER, STRIP GUIDE	30
-	1	1	1	1	1	2119959-3	ASSEMBLY, STRIP GUIDE	29
-	2	2	2	2	2	22281-9	SPRING, COMPRESSION	27
-	1	1	1	1	1	356835-1	LEVER, DRAG RELEASE	26
-	1	1	1	1	1	5-690754-1	DRAG, SPECIAL	25
-	1	1	1	1	1	1633990-1	PLATE, STRIP GUIDE	24
-	1	1	1	1	1	980371-4	SCR, SKT HD SHLDR 5.0 DIA X 6.0	23
-	1	1	1	1	1	2168083-2	SCR, SKT HD CAP, RoHS, M4 X 8.0	21
-	1	1	1	1	1	1-18028-2	WASHER, FLAT, REG M4	20
-	1	1	1	1	1	2119533-1	STRIPPER, SIDE FEED	19
-	-	-	-	-	-	-	-	10
-	-	-	-	-	-	-	-	9
-	1	1	1	1	1	1803065-1	ANVIL, COMBINATION	8
-	-	-	-	-	-	-	-	7
-	-	-	-	-	-	-	-	6
-	-	-	-	-	-	-	-	5
-	1	1	1	1	1	3-238009-8	BLOCK, FL CRIMPER SPACER	4
-	1	1	1	1	1	1803017-2	CRIMPER, INSULATION F	3
-	1	1	1	1	1	1-455888-1	SPACER, CRIMPER	2
-	1	1	1	1	1	1-1633860-3	CRIMPER, WIRE	1
-77	-7	-6	-5	-2	-1	PART NO	DESCRIPTION	ITEM NO

DIMENSIONS:		TOLERANCES UNLESS OTHERWISE SPECIFIED:		APPROVED:		DATE:	
mm	0 PLC ±	1 PLC ±0.1	2 PLC ±0.02	3 PLC ±0.005	4 PLC ±0.0005	ANGLES ±	FINISH
MATERIAL		FINISH		WEIGHT		SCALE	
				A1 00779		C=2151643	

Customer Accessible Production Drawing

LOC		DIST		REVISIONS			
A	66	P	LTM	DESCRIPTION	DATE	DWN	APVD
		-	-	SEE SHEET 1	-	-	-

FEED TYPE MECHANICAL

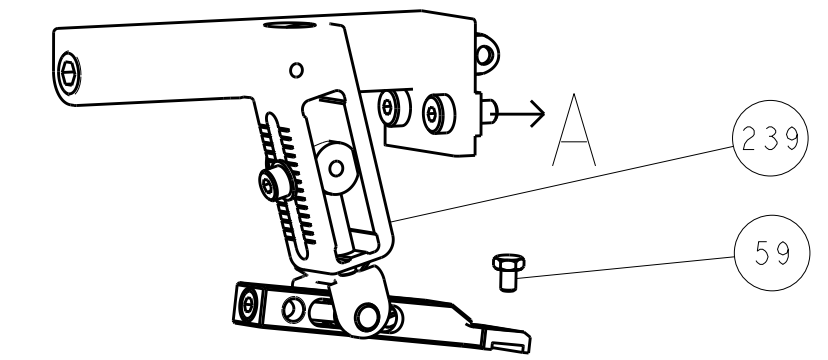

PNEUMATIC

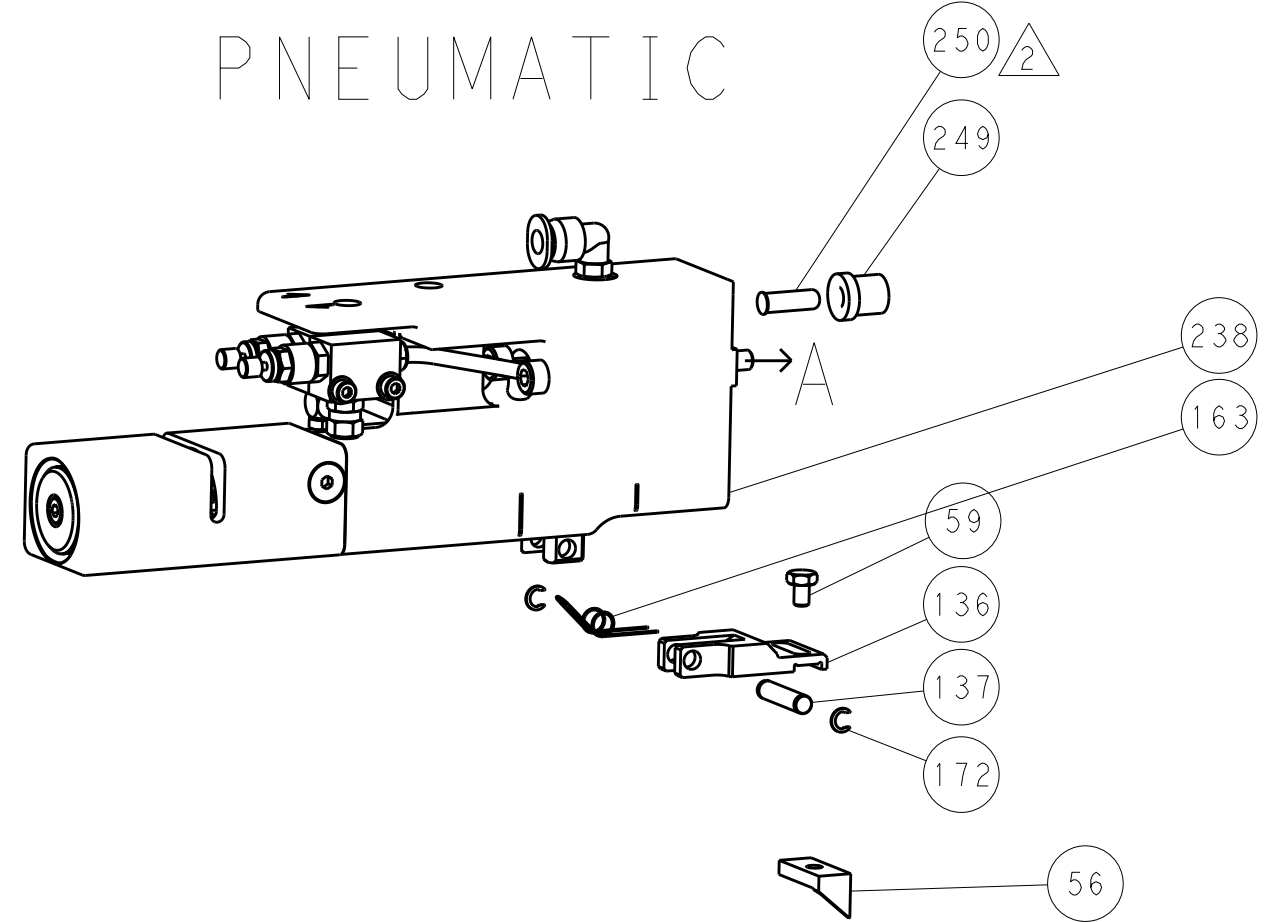

SERVO LATCH PLATE

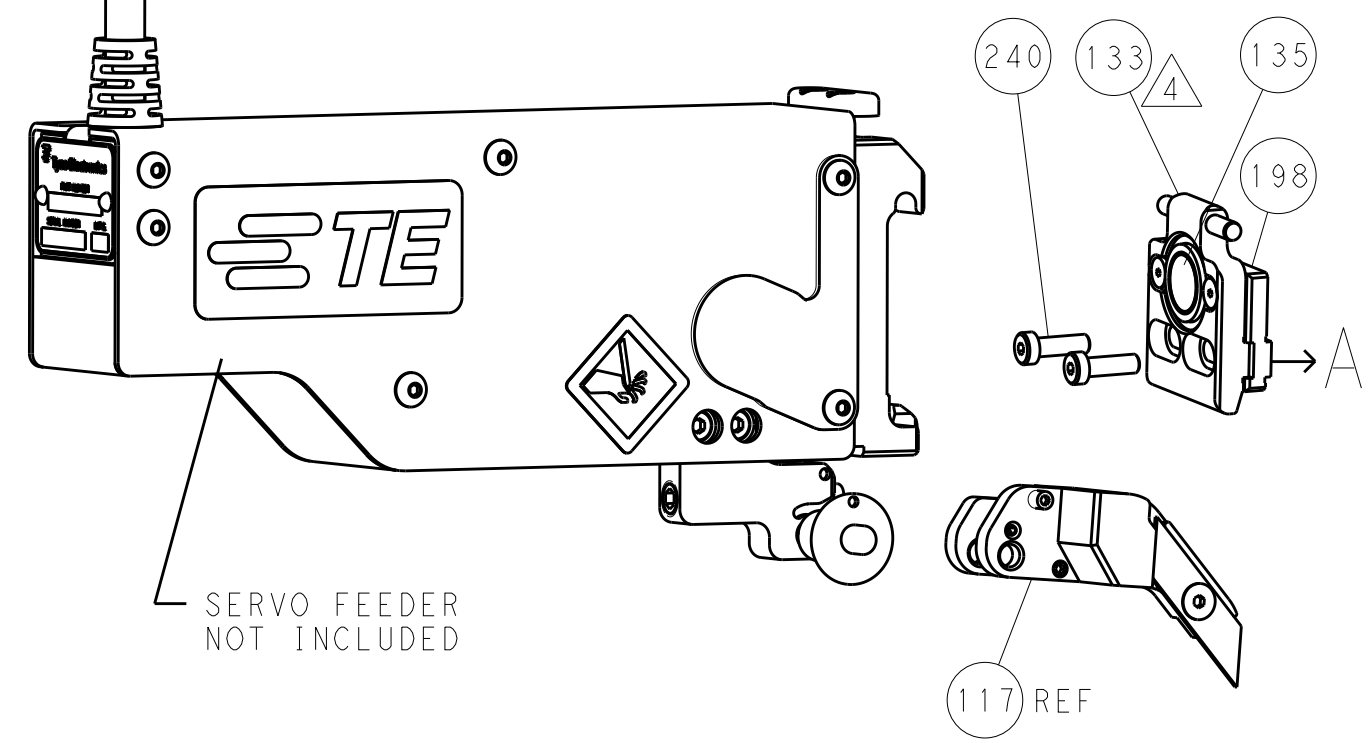

CAM POSITIONS

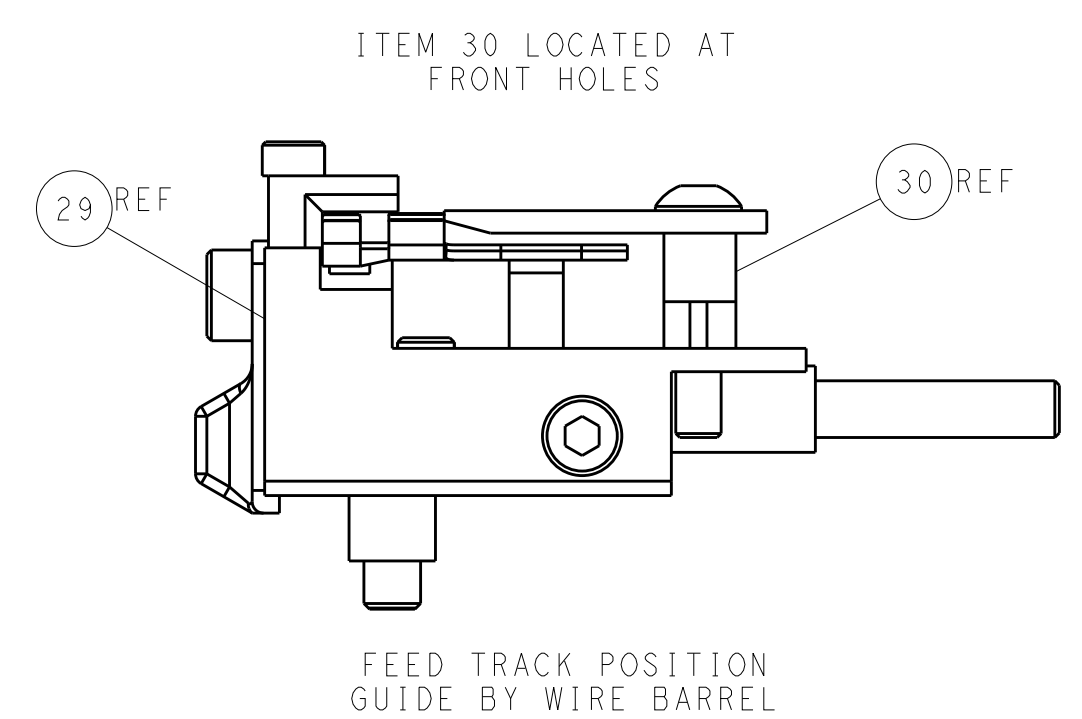
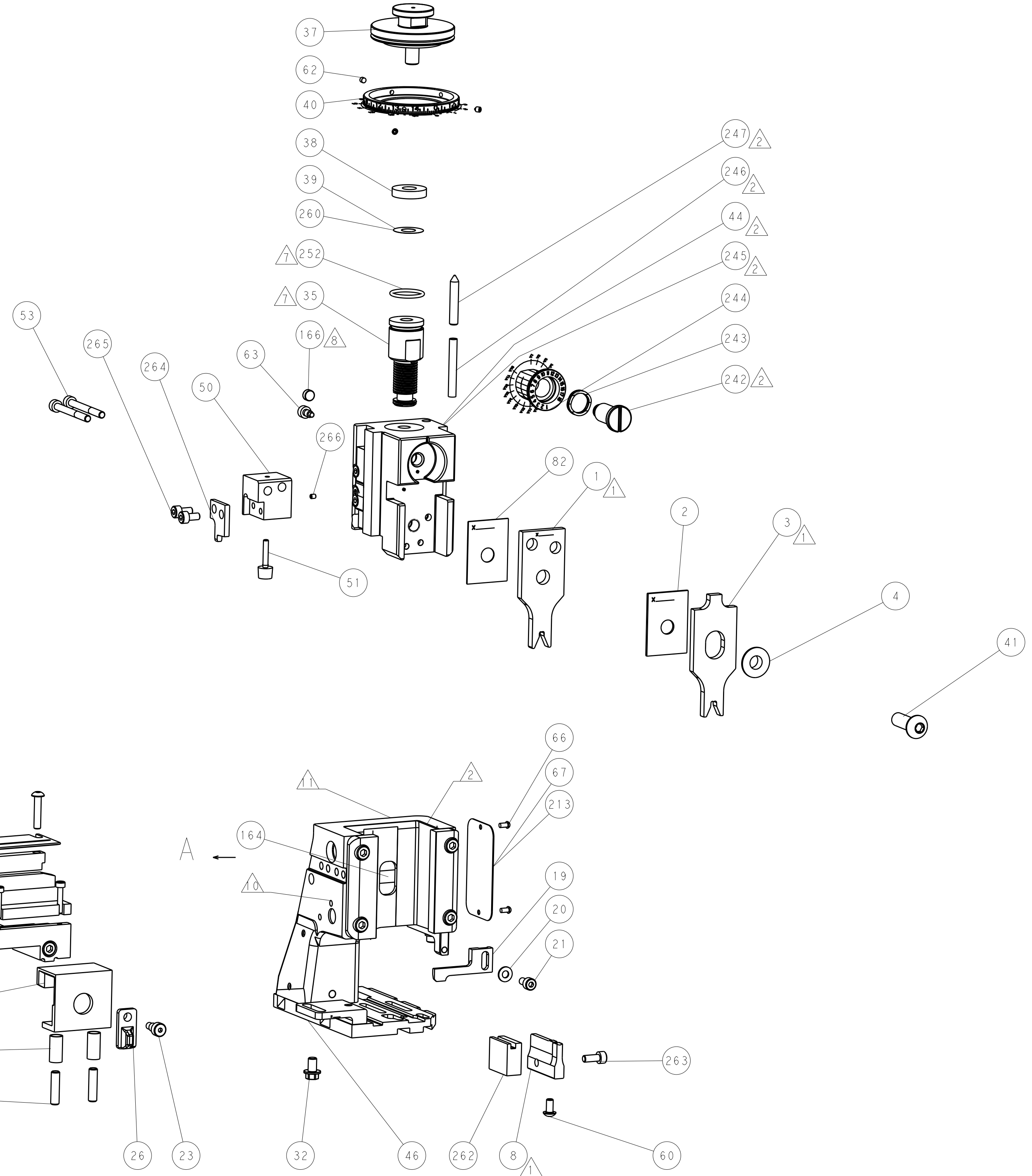
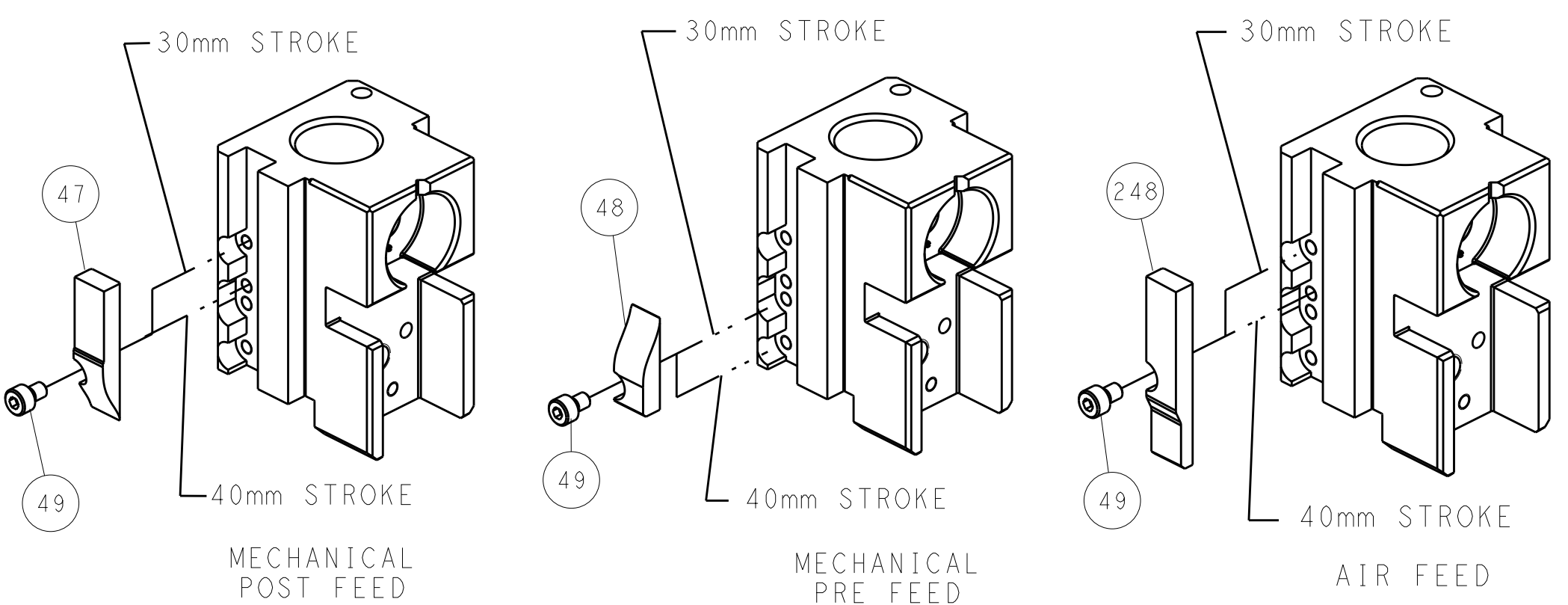

ATLANTIC VERSION
 Shown on sheets 1 of 4 & 2 of 4
 (Pacific version shown on sheets 3 of 4 & 4 of 4)

DIMENSIONS:		TOLERANCES UNLESS OTHERWISE SPECIFIED:		DWN R. KNEPPER 14MAY2012		TE Connectivity	
mm	0 PLC ±0.1	1 PLC ±0.1	2 PLC ±0.02	3 PLC ±0.005	4 PLC ±0.0005	APVD M. CLIFFORD 14MAY2012	Harrisburg, PA 17105-3608
MATERIAL:		FINISH:		NAME Ocean Side Feed Applicator		RESTRICTED TO	
Customer Accessible Production Drawing		SCALE 1:1		SIZE CAGE CODE DRAWING NO. A1 00779 ©=2151643		SHEET 2 OF 4 REV A	

PACIFIC VERSION TERMINATOR INTERFACE ADAPTER	PART NUMBER	REVISION	DESCRIPTION	FEED TYPE	APPLICATOR STYLE CONVERSION CHART						
					CONVERT TO	PART NUMBERS REQUIRED					
	2-2151643-1	A	FINE CRIMP HEIGHT ADJUST	MECHANICAL	PNEUMATIC FEED	2119950-1	1338683-3	5-18022-5	2119641-2	2119799-1	2063440-1
					SERVO LATCH PLATE	2119951-1	-	8-2151643-5	1901094-3	-	2168400-6 (QUANTITY 2)
					SMART APPLICATOR	2161326-1	-	8-2151643-4	-	-	-
	2-2151643-2	A	FINE CRIMP HEIGHT ADJUST	PNEUMATIC	MECHANICAL FEED	2119949-1	1338683-3	5-18022-5	2119653-2	-	-
					SERVO LATCH PLATE	2119951-1	-	8-2151643-5	1901094-3	-	2168400-6 (QUANTITY 2)
					SMART APPLICATOR	2161326-1	-	8-2151643-4	-	-	-
	2-2151643-5	A	FINE CRIMP HEIGHT ADJUST	SERVO LATCH PLATE ⁴	MECHANICAL FEED	2119949-1	1338683-3	5-18022-5	2119653-2	-	-
					PNEUMATIC FEED	2119950-1	1338683-3	5-18022-5	2119641-2	2119799-1	2063440-1
	2-2151643-7	A	FINE CRIMP HEIGHT ADJUST	NONE	-	-	-	-	-	-	-
	7-2151643-7	A	CRIMP TOOLING KIT	-	-	-	-	-	-	-	-

APPLICATOR DATA		
CRIMP WIRE	SIZE	TYPE
INSUL	2.92 mm [1.15]	F
	3.81 mm [1.50]	F
APPLICATOR INSTRUCTIONS 408-10389		

TERMINAL DATA: DELPHI PACKARD TERMINAL & SPECIFICATION			
TERMINAL NAME: RING			
WIRE STRIP LENGTH 6.70-7.50 mm [1.264-.295 IN]		INSULATION DIAMETER RANGE Ø2.03-2.40 mm [1.080-.094 IN]	
TERMINAL APPLICATION SPECIFICATION	02989521 Rev -	-	-
TERMINALS APPLIED			
TE TERMINAL	DELPHI PACKARD TERMINAL	TE TERMINAL	DELPHI PACKARD TERMINAL
2113266-1	02989521		

WIRE SIZE	CRIMP HEIGHT mm [INCH]	CRIMP HEIGHT REFERENCE SETTING
0.80mm2	2.20+/-0.05 [1.087+/-0.002]	11.2
0.50mm2	2.15+/-0.05 [1.085+/-0.002]	12.0

- RECOMMENDED SPARE PARTS
- GREASE BEARING SURFACES LIGHTLY
- 3. LUBRICATE DAILY PER THE APPLICATOR INSTRUCTION SHEET SUPPLIED WITH THE APPLICATOR.
- APPLICATOR SPECIFIC DATA TO BE ENTERED INTO BLANK MEMORY CHIP AT ASSEMBLY. SEE BELOW FOR PART NUMBER:
 MECHANICAL FEED WITH "SMART APPLICATOR" CONVERSION: 8-2151643-4
 PNEUMATIC FEED WITH "SMART APPLICATOR" CONVERSION: 8-2151643-4
 SERVO FEED WITH "FINE CRIMP HEIGHT ADJUST": 8-2151643-5
- 5. ADJUSTMENT OF THE STRIPPER MAY BE REQUIRED WHEN MOVING THE APPLICATOR BETWEEN BENCH AND LEADMAKER APPLICATIONS.
- APPLY PART NUMBER 1-23419-5 LOCTITE TO THREADS OF ITEM 50.
- GREASE THREADS, GROOVE AND O-RING ON ITEMS 139 & 152.
- MAGNET MUST BE ORIENTED CORRECTLY IN ORDER TO PROPERLY ACTUATE THE COUNTER.
- CRIMP HEIGHT REFERENCE SETTING WAS THE SETTING USED WHEN THE APPLICATOR WAS QUALIFIED AT THE FACTORY. ADJUSTMENT MAY BE NECESSARY WHEN RUNNING APPLICATOR IN THE FIELD.
- SPARE FEED CAM STORAGE LOCATION REFER TO INSTRUCTION SHEET FOR ADDITIONAL INFORMATION.

***WARNING**
 ON INSTALLATION, SET WIRE DISC, ITEM 40 TO LARGEST WIRE SIZE SETTING. USE OF SETTINGS BELOW MINIMUM REQUIRED CRIMP HEIGHT SETTING WILL CAUSE DAMAGE TO CRIMP TOOLING.

-	1	1	1	1	3-18031-6	SCR, SET, CUP POINT M2.5 X 3.0	266
-	2	2	2	2	2168083-2	SCR, SKT HD CAP, RoHS, M4 X 8.0	265
-	1	1	1	1	1-1583859-9	BLADE, SLUG	264
-	1	1	1	1	1-2168083-0	SCR, SKT HD CAP, RoHS, M4 X 10	263
-	1	1	1	1	2119924-4	SHEAR, LOWER	262
-77	-27	-25	-22	-21	PART NO	DESCRIPTION	ITEM NO

PACIFIC VERSION
 Shown on sheets 3 of 4 & 4 of 4
 (Atlantic version shown on sheets 1 of 4 & 2 of 4)

SET UP GAUGE	LOC	DIST	REVISIONS			
2119599-1	A	66	REV	DATE	BY	APPV
			-	SEE SHEET 1	-	-

-	1	1	1	1	2119782-1	FINE ADJUST HEAD ASM, PACIFIC STYLE	251
-	-	-	1	-	2119640-1	PUSH ROD, AIR FEED	250
-	-	-	1	-	2079988-1	BUSHING, LCH5-12, MISUMI	249
-	1	1	1	1	1-22279-3	SPRING, COMPRESSION	246
-	1	1	1	1	2119082-6	CAM, SNAIL, INSULATION ADJUSTMENT	244
-	1	1	1	1	2079764-1	WASHER, WAVE SPRING, CREST-TO-CREST	243
-	1	1	1	1	2119083-1	RETAINER, INSULATION DIAL	242
-	-	2	-	-	2168400-6	SHCS, LOW HEAD, RoHS, M5 X 16	240
-	-	-	-	1	2119580-1	MECHANICAL FEED ASSEMBLY	239
-	-	-	-	1	2063440-1	AIR FEED MODULE	238
-	-	1	-	-	2119740-2	TAG, IDENTIFICATION	213
-	-	1	-	-	1901094-3	SPACER, FEEDER	198
-	-	-	2	-	21045-3	RING, RETAIN, EXTERN, 3/16 CRESCENT	172
-	1	1	1	1	994969-1	MAGNET, RARE EARTH HIGH ENERGY	166
-	REF	REF	REF	REF	994970-2	COUNTER, MAGNETIC	164
-	-	-	1	-	240638-1	SPRING, FEED FINGER	163
-	1	1	1	1	8-21084-1	O-RING, .801 ID, .070 DIA. MAT.	152
-	-	-	1	-	2119641-2	FEED CAM, AIR FEED	151
-	1	1	1	1	2119798-2	DETENT PIN	145
-	1	1	1	1	2079383-8	SCR, BHSC, RoHS (M4 X 16)	144
-	-	-	-	1	2119653-2	FEED CAM, POST FEED	142
-	1	1	1	1	2119656-2	APPLICATOR BASIC ASSEMBLY, SF	141
-	1	1	1	1	2119650-1	RAM, ASIAN STYLE, SIDE FEED	140
-	1	1	1	1	2119092-2	BOLT, ADJUSTMENT	139
-	-	-	1	-	3-23627-7	PIN, RETAIN, GRVD, 3/16 X .854	137
-	-	-	1	-	2119799-1	HOLDER, FEED FINGER, AF	136
-	-	REF	-	-	SEE NOTE 4	MEMORY CHIP, PROGRAMMED	135
-	-	1	-	-	1633743-1	SERVO FEED LATCH ASM	133
-	-	REF	-	-	2119944-1	FEED FINGER ASSEMBLY, SF	117
-	1	1	1	1	1-690712-0	FRONT STRIP GUIDE	96
-	2	2	2	2	1-2168083-3	SCR, SKT HD CAP, RoHS, M3 X 16	95
-	1	1	1	1	455888-5	SPACER, CRIMPER	82
-	2	2	2	2	2168083-1	SCR, SKT HD CAP, RoHS, M3 X 8.0	79
-	1	1	1	1	1633782-4	FENCE	78
-	1	1	1	1	2119956-1	DOCUMENTATION PACKAGE	71
-	1	-	1	1	2119740-1	TAG, IDENTIFICATION	67
-	2	2	2	2	2168078-1	SCREW, DRIVE, RH, RoHS	66
-	1	1	1	1	2119793-1	LIMITER, ADJUSTMENT BOLT	63
-	3	3	3	3	992763-5	SCR, SET, SOC, CONE POINT, M3 X 4.0	62
-	2	2	2	2	2-18032-5	SCR, SET, FLT POINT M5 X 20.0	61
-	-	-	1	1	5-18022-5	SCR, HEX HD CAP, M4 X 6.0	59
-	-	-	1	1	1338683-3	FEED PAWL	56
-	2	2	2	2	1-18023-7	SCR, SKT HD CAP M4 X 40.0	53
-	1	1	1	1	811242-5	BUMPER, HOLD DOWN	51
-	1	1	1	1	2119830-7	HOLDER, SLUG BLADE	50
-	-	-	1	2	18023-9	SCR, SKT HD CAP M4 X 6.0	49
-	-	-	-	1	2119652-1	FEED CAM, PRE FEED	48
-	1	1	1	1	2079383-7	SCR, BHSC, RoHS (M8 X 25)	41
-	1	1	1	1	2119645-1	DISC, NUMBERED FA WIRE ADJUSTMENT	40
-	1	1	1	1	2119957-1	APPLICATOR SHIM PACK	39
-	1	1	1	1	2119644-3	RAM WASHER, PRECISION	38
-	2	2	2	2	2079383-5	SCR, BHSC, RoHS (M4 X 20)	33
-	1	1	1	1	2161328-1	HEX HEAD, FLANGED, M5 X 8mm LONG	32
-	1	1	1	1	1-1320908-6	SPACER, STRIP GUIDE	30
-	1	1	1	1	2119959-3	ASSEMBLY, STRIP GUIDE	29
-	2	2	2	2	22281-9	SPRING, COMPRESSION	27
-	1	1	1	1	356835-1	LEVER, DRAG RELEASE	26
-	1	1	1	1	5-690754-1	DRAG, SPECIAL	25
-	1	1	1	1	1633990-1	PLATE, STRIP GUIDE	24
-	1	1	1	1	980371-4	SCR, SKT HD SHLDR 5.0 DIA X 6.0	23
-	1	1	1	1	2168083-2	SCR, SKT HD CAP, RoHS, M4 X 8.0	21
-	1	1	1	1	1-18028-2	WASHER, FLAT, REG M4	20
-	1	1	1	1	2119533-1	STRIPPER, SIDE FEED	19
-	-	-	-	-	-	-	10
-	-	-	-	-	-	-	9
-	-	-	-	-	-	-	7
-	-	-	-	-	-	-	6
-	-	-	-	-	-	-	5
-	1	1	1	1	3-238009-8	BLOCK, FL CRIMPER SPACER	4
-	1	1	1	1	1803017-2	CRIMPER, INSULATION F	3
-	1	1	1	1	1-455888-1	SPACER, CRIMPER	2
-	1	1	1	1	1-1633860-3	CRIMPER, WIRE	1
-77	-27	-25	-22	-21	PART NO	DESCRIPTION	ITEM NO

DIMENSIONS:		TOLERANCES UNLESS OTHERWISE SPECIFIED:		DRAWN		CHK		APPV		NAME	
mm	0 PLC ±.1	1 PLC ±.05	2 PLC ±.02	3 PLC ±.01	4 PLC ±.005	ANGLES ±.0005	FINISH	DRW	14MAY2012	14MAY2012	14MAY2012
								DR	R. KNEPPER	G. BAILEY	M. CLIFFORD
								NAME	Ocean Side Feed Applicator		
								SIZE	CAGE CODE	DRAWING NO	RESTRICTED TO
								A1	00779	2151643	REV A
								Customer Accessible Production Drawing			SCALE 1:1 SHEET 3 OF 4

LOC		DIST		REVISIONS			
A	66	P	LTM	DESCRIPTION	DATE	DWN	APVD
				SEE SHEET 1			

DIMENSIONING AND TOLERANCING PER ASME Y14.5M-2003

FEED TYPE MECHANICAL

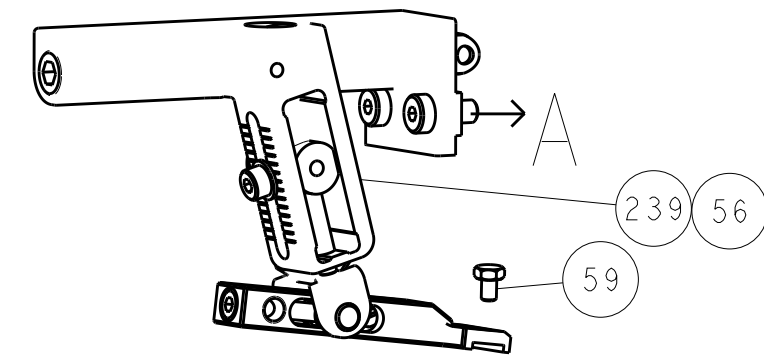

PNEUMATIC

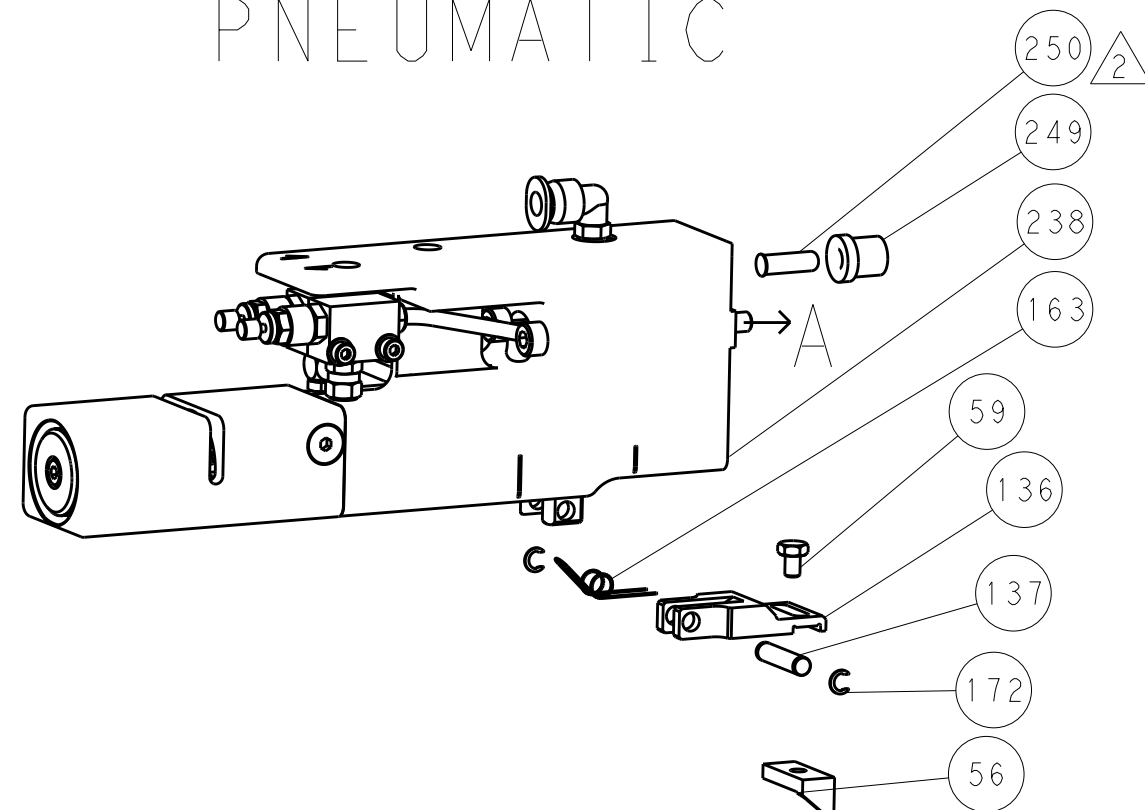

SERVO LATCH PLATE

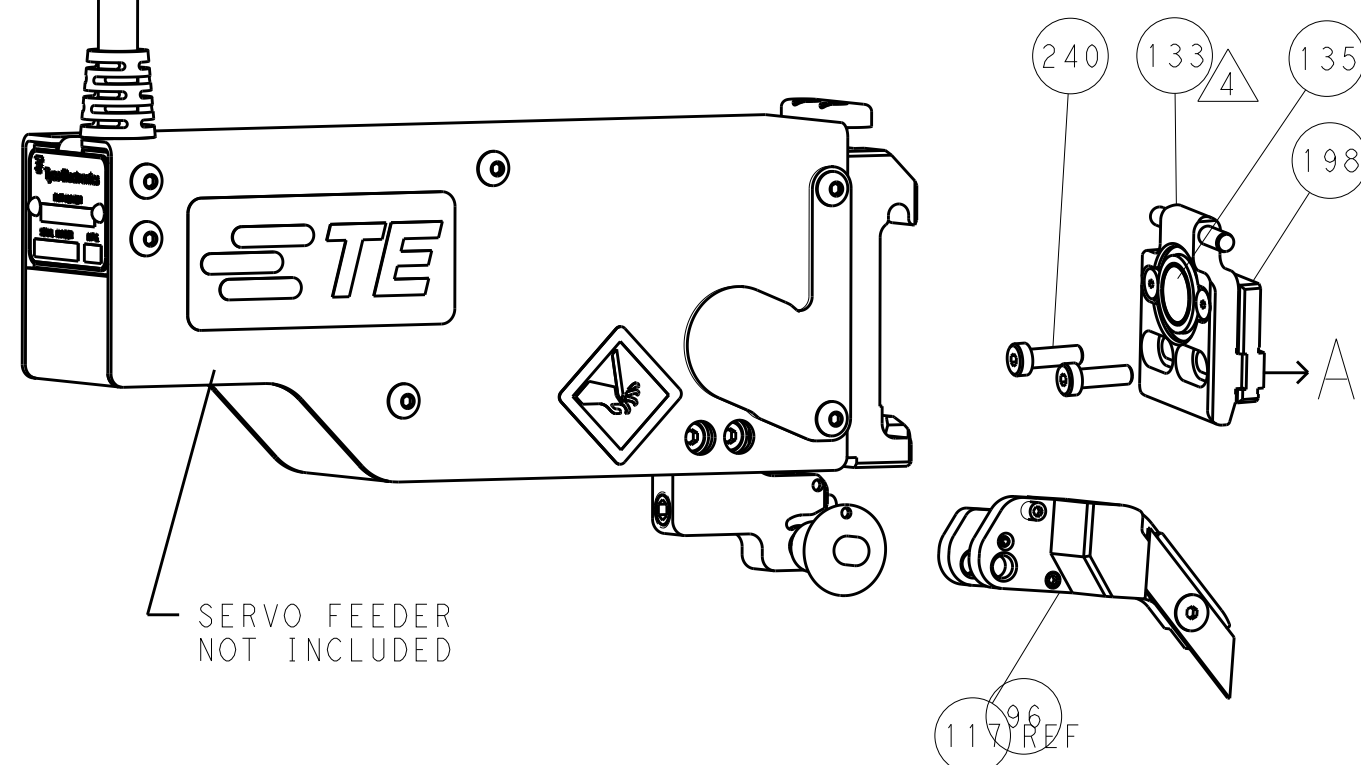

CAM POSITIONS

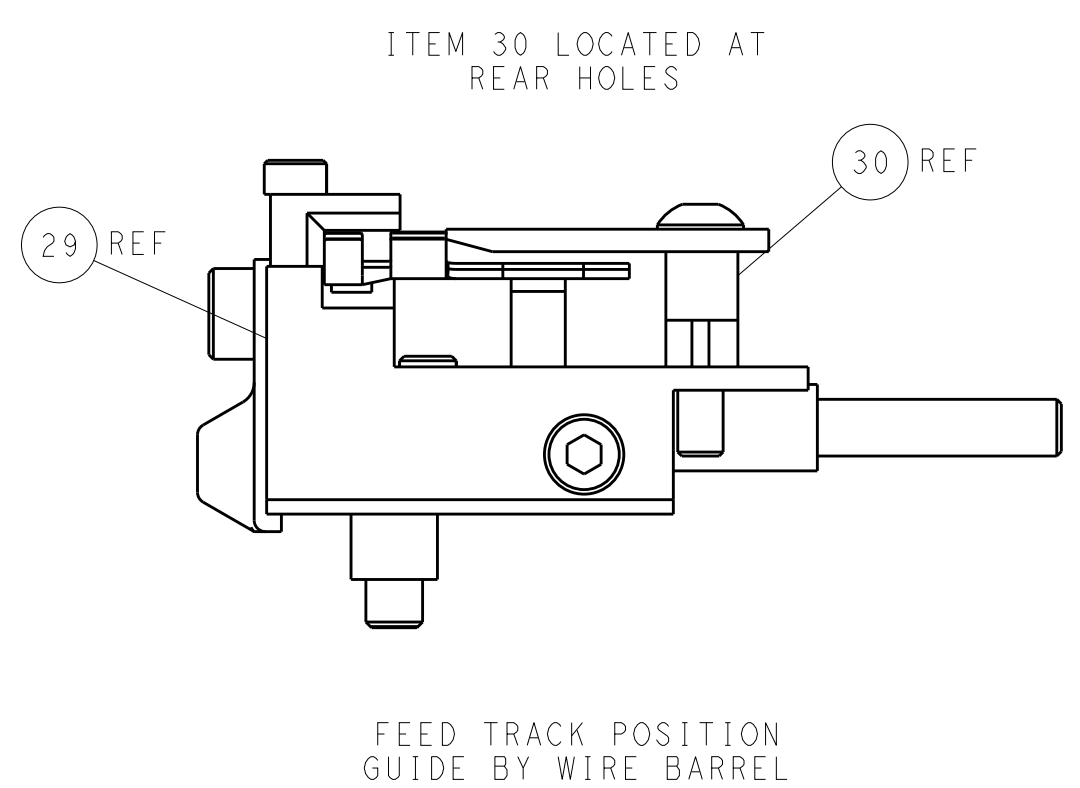
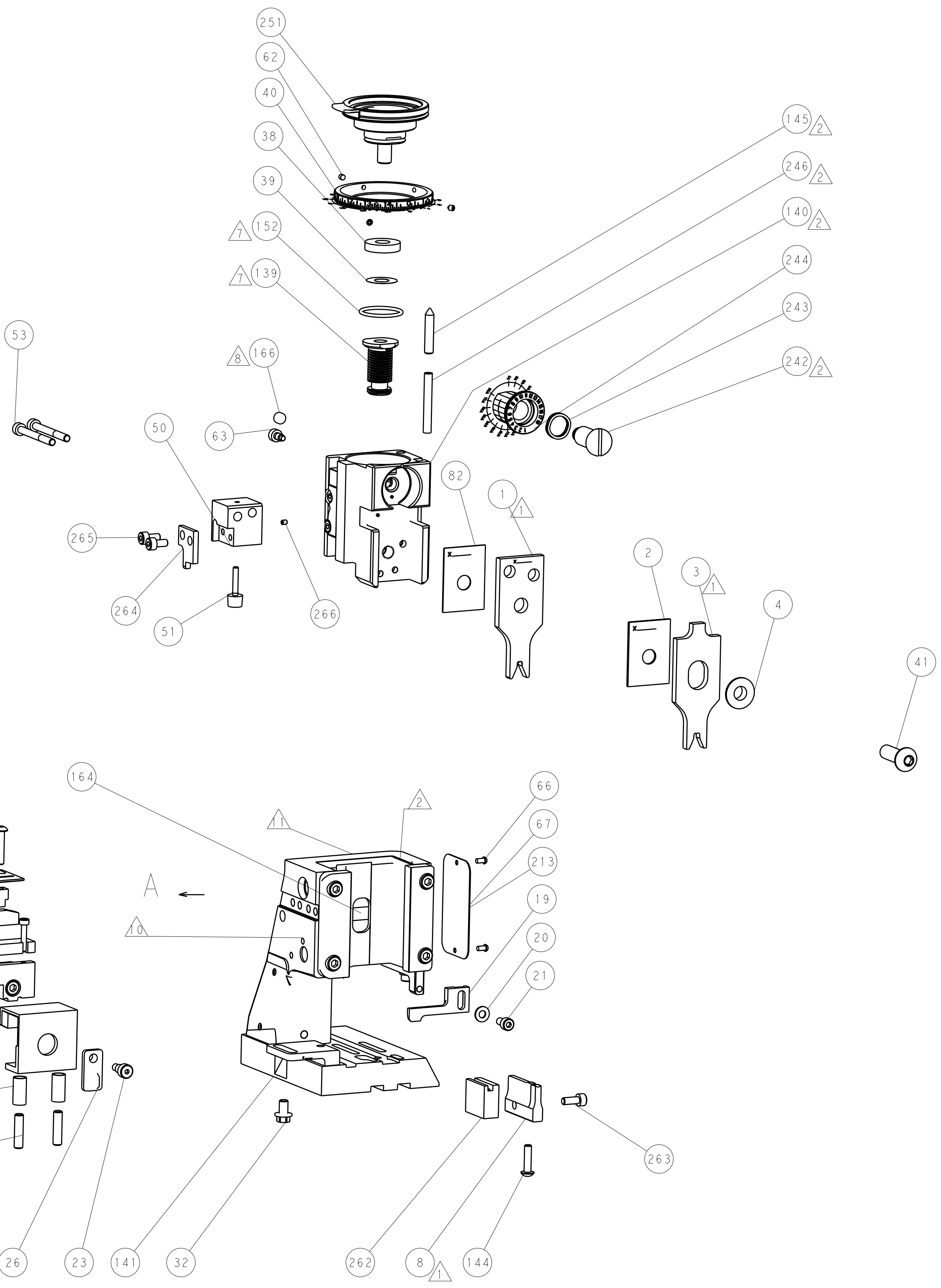
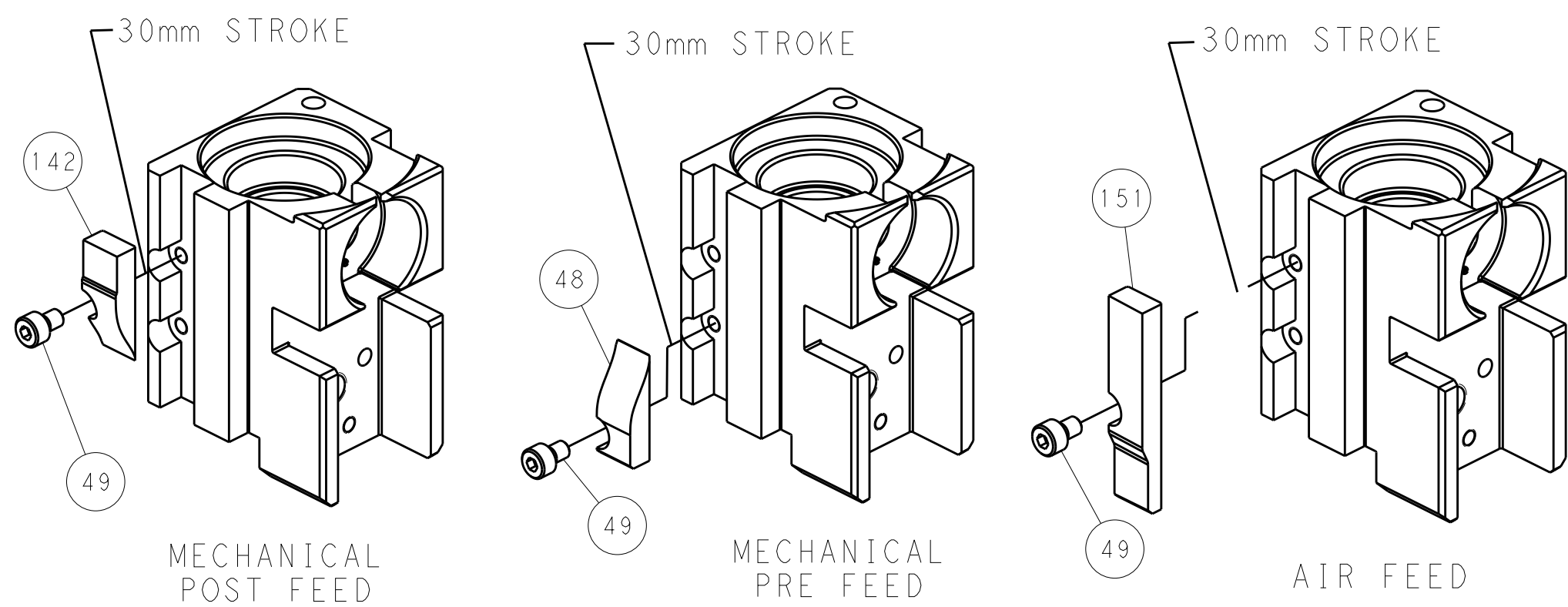

PACIFIC VERSION
 Shown on sheets 3 of 4 & 4 of 4
 (Atlantic version shown on sheets 1 of 4 & 2 of 4)

DIMENSIONS:		TOLERANCES UNLESS OTHERWISE SPECIFIED:		DWN R. KNEPPER 14MAY2012		STE TE Connectivity	
mm	0 PLC ±0.1	1 PLC ±0.1	2 PLC ±0.02	3 PLC ±0.02	CHK G. BAILEY 14MAY2012	Harrisburg, PA 17105-3608	
	4 PLC ±0.005	5 PLC ±0.005	6 PLC ±0.005	7 PLC ±0.005	APVD M. CLIFFORD 14MAY2012	NAME	
	ANGLES ±	FINISH		PRODUCT SPEC		Ocean Side Feed Applicator	
MATERIAL				APPLICATION SPEC		RESTRICTED TO	
				WEIGHT		SIZE CAGE CODE DRAWING NO	
				A 00779 C=2151643		Customer Accessible Production Drawing	
				SCALE 1:1		SHEET 4 OF 4 REV A	