

DO NOT SCALE FROM THIS PRINT

BSW-1XX-X4-X-X-X

No OF POSITIONS
-02 THRU -36 (PER ROW)
LEAD STYLE
-04: C-8-5-X (STANDARD I/W FORCES)
-24: C-17-5-X (LOW I/W FORCES)

OPTION
-S: STANDOFFS (USE BSW-36-X-S, SEE TABLE 1)
ROW SPECIFICATION
SEE TABLE 1

PLATING SPECIFICATION

-G: 20μ" GOLD IN CONTACT AREA, 3μ" GOLD ON TAIL
-T: MATTE TIN CONTACT AND TAIL (STYLE -04 ONLY)
-S: 30μ" SELECTIVE GOLD IN CONTACT AREA, MATTE TIN ON TAIL
-H: 30μ" HEAVY GOLD IN CONTACT AREA, 3μ" GOLD ON TAIL (STYLE -04 ONLY)
-L: 10μ" SELECTIVE GOLD IN CONTACT AREA, MATTE TIN ON TAIL

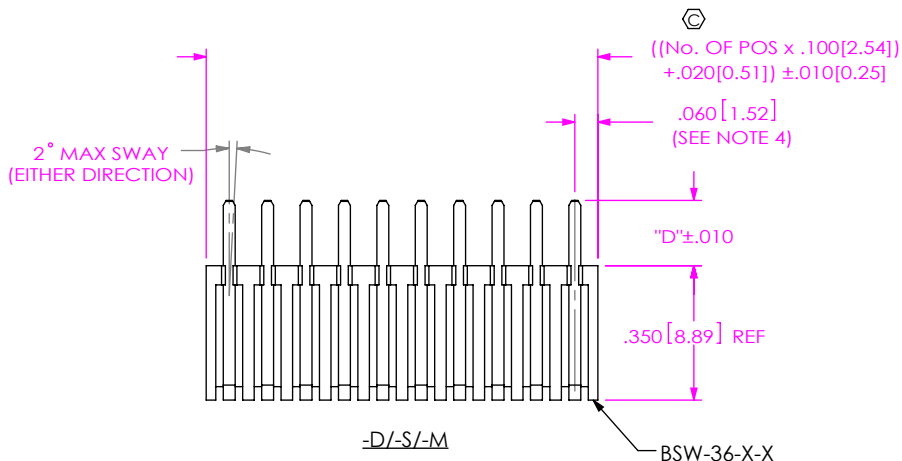

ROW / OPTION	"B"	"C"	"D"	USE BODY
- D	.100 [2.54]	—	.165 [4.19]	BSW-36-D
- S	.100 [2.54]	—	.170 [4.32]	BSW-36-S
- M	.150 [3.81]	—	.125 [3.18]	BSW-36-M
- D - S	.100 [2.54]	.15 [3.8]	—	BSW-36-D-S
- S - S	.100 [2.54]	.15 [3.8]	—	BSW-36-S-S

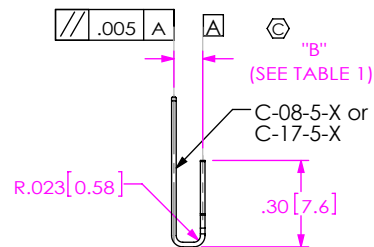
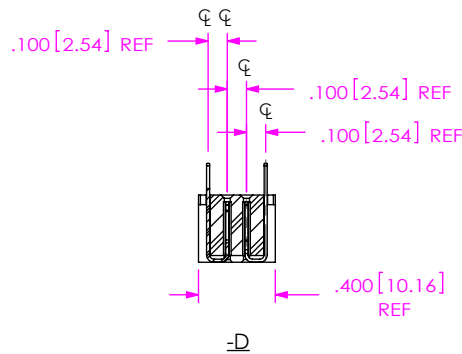
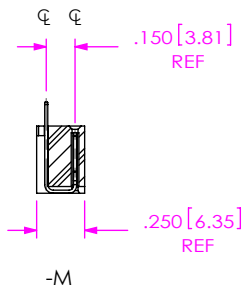
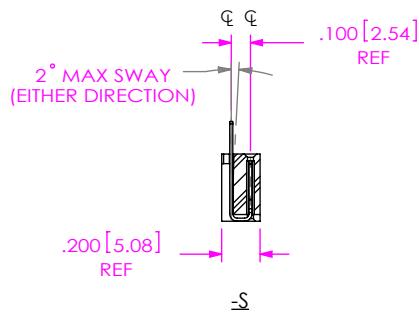

CONTACT SCALE 1.5:1
CRITICAL 1 DIMMENSION MUST BE VERIFIED AT BEGINNING, MIDDLE, AND END OF EACH LOT

FINAL ASSEMBLY

NOTES:

- ⊗ REPRESENTS A CRITICAL DIMENSION.
- MINIMUM PUSHOUT FORCE: 3lbs.
- MAXIMUM ALLOWABLE BOW: T/B .003[.08] INCH/INCH, S/S .008[0.20] INCH/INCH AFTER ASSEMBLY.
- "END WALLS" AFTER CUTTING SHOULD BE .023[.58]
- MAXIMUM CUT FLASH: .010[.25]
- THE IDENTIFICATION SIDE IS TO BE DOWN OR AGAINST THE FORM TOOLING.

POSITION NUMBER LAYOUT

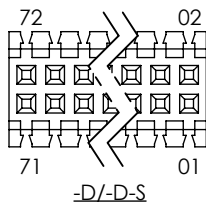
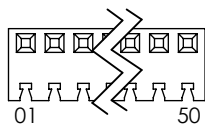
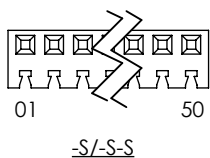

UNLESS OTHERWISE SPECIFIED, DIMENSIONS ARE IN INCHES.

TOLERANCES ARE:

DECIMALS ANGLES
.XX: ±.01 [.3] 2°
.XXX: ±.005 [.13]
.XXXX: ±.0020 [.051]

PROPRIETARY NOTE

THIS DOCUMENT CONTAINS CONFIDENTIAL AND PROPRIETARY INFORMATION AND ALL DESIGN, MANUFACTURING, REPRODUCTION, USE, PATENT RIGHTS AND SALES RIGHTS ARE EXPRESSLY RESERVED BY SAMTEC, INC. THIS DOCUMENT SHALL NOT BE DISCLOSED, IN WHOLE OR PART, TO ANY UNAUTHORIZED PERSON OR ENTITY NOR REPRODUCED, TRANSFERRED OR INCORPORATED IN ANY OTHER PROJECT IN ANY MANNER WITHOUT THE EXPRESS WRITTEN CONSENT OF SAMTEC, INC.

DO NOT SCALE DRAWING

SHEET SCALE: 2:1

MATERIAL:
INSULATOR: PET, UL 94 VO, COLOR: BLACK
CONTACT: PHOS BRONZE

DESCRIPTION:
.100 BOTTOM MOUNT SOCKET ASSEMBLY

DWG. NO. **BSW-1XX-X4-X-X-X**

BY: PURVIS 03/31/1998 SHEET 1 OF 2



520 PARK EAST BLVD, NEW ALBANY, IN 47150
PHONE: 812-944-6733 FAX: 812-948-5047
e-Mail: info@SAMTEC.com code 55322

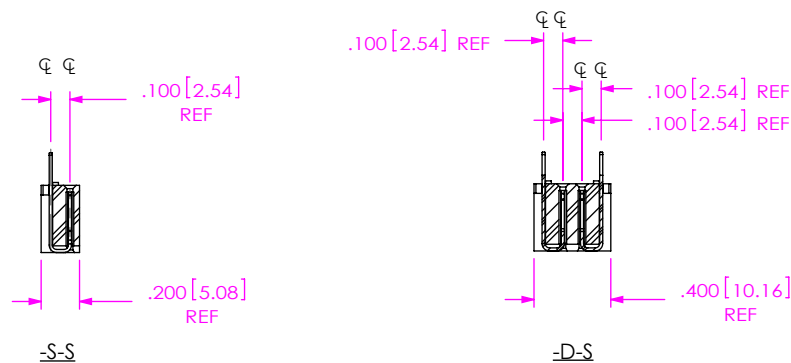
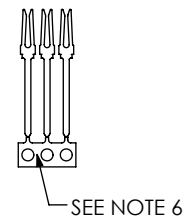
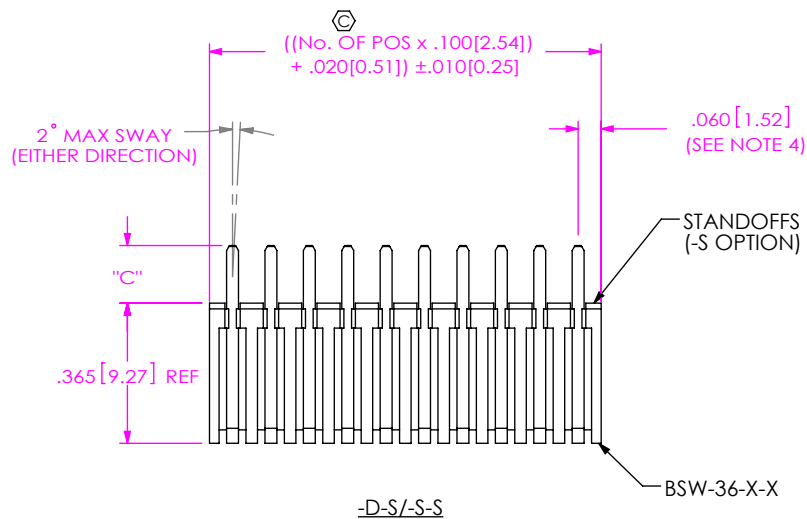

FINAL ASSEMBLY

PROPRIETARY NOTE
 THIS DOCUMENT CONTAINS CONFIDENTIAL AND PROPRIETARY INFORMATION AND ALL DESIGN, MANUFACTURING, REPRODUCTION, USE, PATENT RIGHTS AND SALES RIGHTS ARE EXPRESSLY RESERVED BY SAMTEC, INC. THIS DOCUMENT SHALL NOT BE DISCLOSED, IN WHOLE OR PART, TO ANY UNAUTHORIZED PERSON OR ENTITY NOR REPRODUCED, TRANSFERRED OR INCORPORATED IN ANY OTHER PROJECT IN ANY MANNER WITHOUT THE EXPRESS WRITTEN CONSENT OF SAMTEC, INC.

DO NOT SCALE DRAWING

SHEET SCALE: 2:1



520 PARK EAST BLVD, NEW ALBANY, IN 47150
 PHONE: 812-944-6733 FAX: 812-948-5047
 e-Mail info@SAMTEC.com code 55322

DESCRIPTION:
 .100 BOTTOM MOUNT SOCKET ASSEMBLY

DWG. NO.
BSW-1XX-X4-X-X-X

BY: PURVIS 03/31/1998 SHEET 2 OF 2