

THIS DRAWING IS UNPUBLISHED. RELEASED FOR PUBLICATION
 © COPYRIGHT BY TYCO ELECTRONICS CORPORATION. ALL INTERNATIONAL RIGHTS RESERVED.

LOC	DIST	REVISIONS					
AF	50	P	LTR	DESCRIPTION	DATE	DWN	APVD
			B	REVISED PER ECR-10-004058	09JUN10	HMR	PD

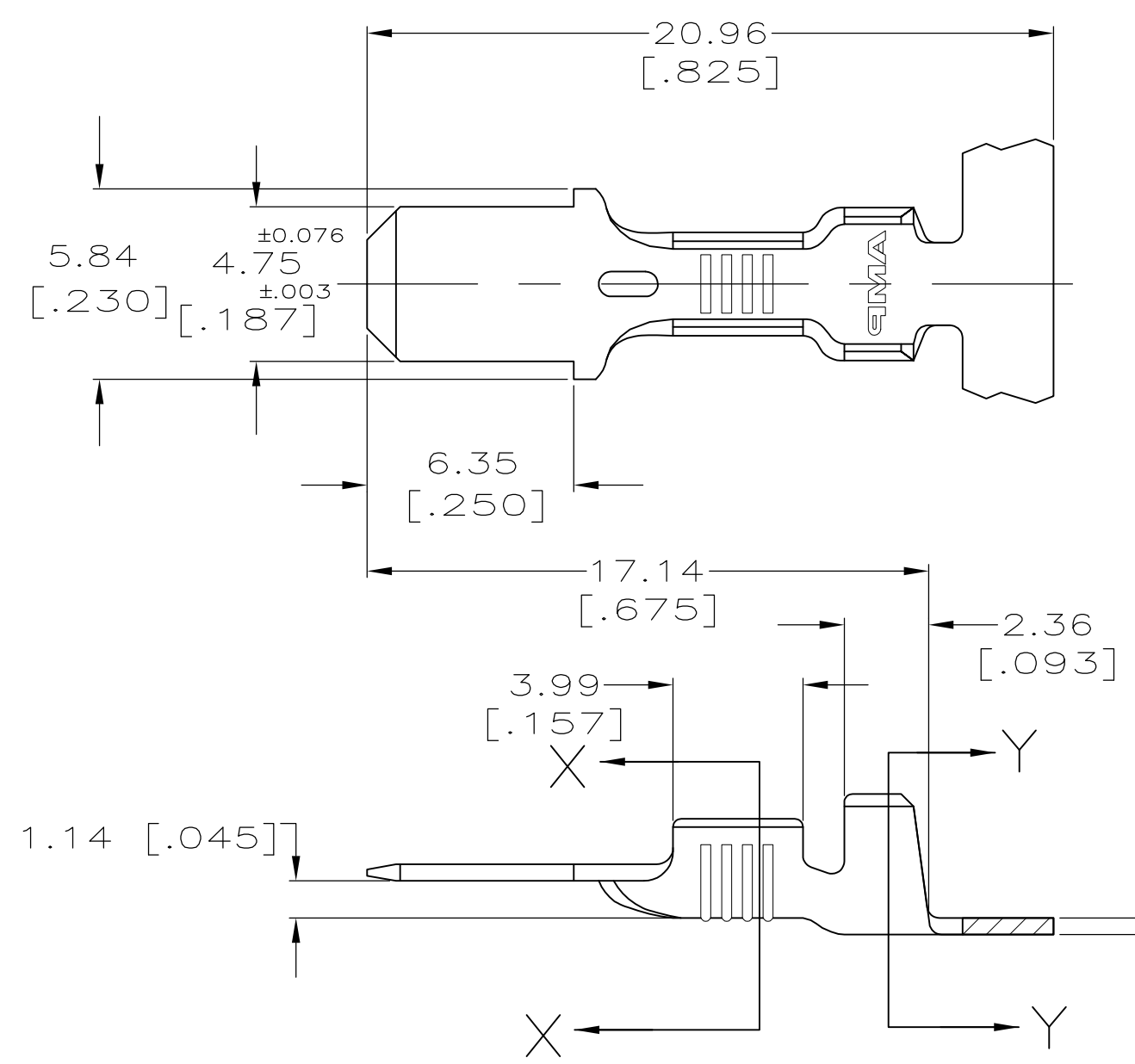

1. CONTINUOUS STRIP ON REELS.
2. FEED TO BE 11.18±0.076 [.440±.003].

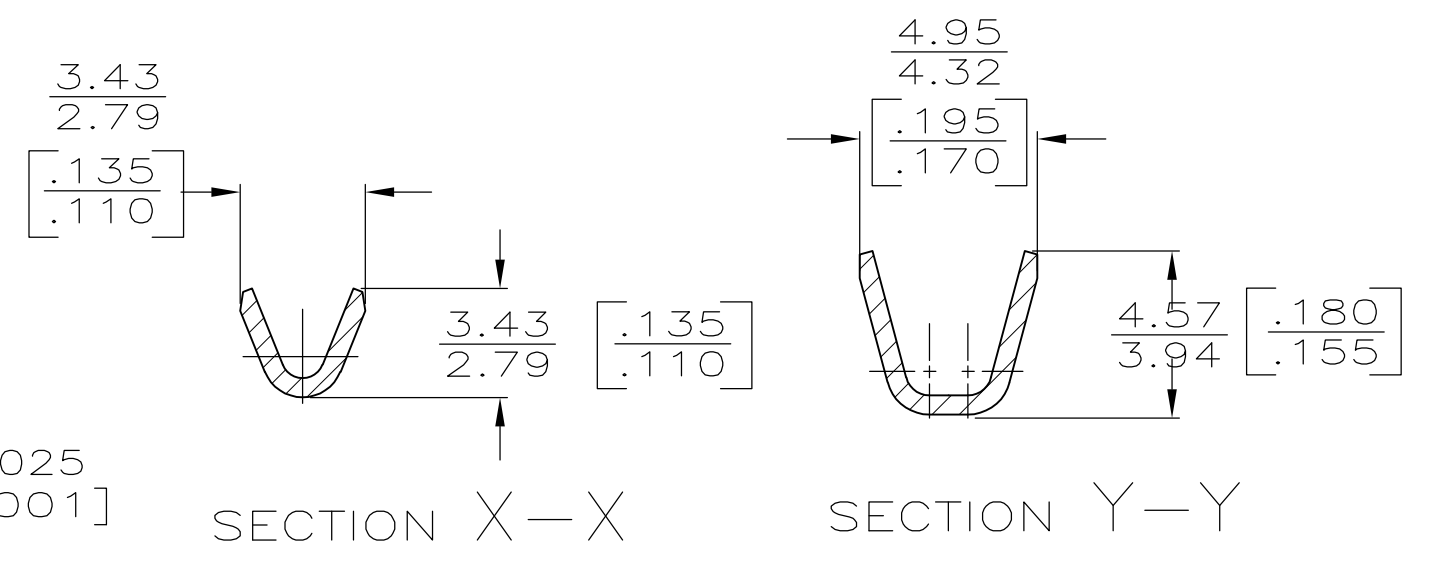

1.52-3.05 DIA [.060-.120] DIA	[#22-#18] AWG	63857-1
INSULATION RANGE	WIRE SIZE	PART NO

0	3.30 [.130]	5.59 [.220]	F	2.29 [.090]	1.65 [.065] [#18] 1.52 [.060] [#20] 1.45 [.057] [#22]	WIRE
TYPE	WIDTH	±0.38 [±.015] STRIP LENGTH	TYPE	WIDTH	±0.051 [.002] HEIGHT	WIRE
INSUL BARREL CRIMP			WIRE BARREL CRIMP			

THIS DRAWING IS A CONTROLLED DOCUMENT.

DIMENSIONS: mm [INCHES]	TOLERANCES UNLESS OTHERWISE SPECIFIED:	DWN JR RUTH 5/9/95	 Tyco Electronics Corporation Harrisburg, PA 17105-3608			
	0 PLC ± -	CHK MS FEHER 5/9/95				
	1 PLC ± -	APVD P DESANTIS 5/9/95				
	2 PLC ± 0.25 [.010]	NAME TAB, FASTON, 4.75 [.187] SERIES				
3 PLC ± -	PRODUCT SPEC	SIZE	CAGE CODE	DRAWING NO	RESTRICTED TO	
4 PLC ± -	FINISH	WEIGHT	A3	00779	C-63857	-
MATERIAL 082 BRASS	TIN	CUSTOMER DRAWING	SCALE	SHEET	REV	
			5:1	1 OF 1	B	