

THIS DRAWING IS UNPUBLISHED. RELEASED FOR PUBLICATION
 © COPYRIGHT - By - ALL RIGHTS RESERVED.

LOC		DIST		REVISIONS			
P	LTR	DESCRIPTION		DATE	DWN	APVD	
AF	50	AB	REVISED PER ECR-12-016352	17NOV12	KH	GJ	

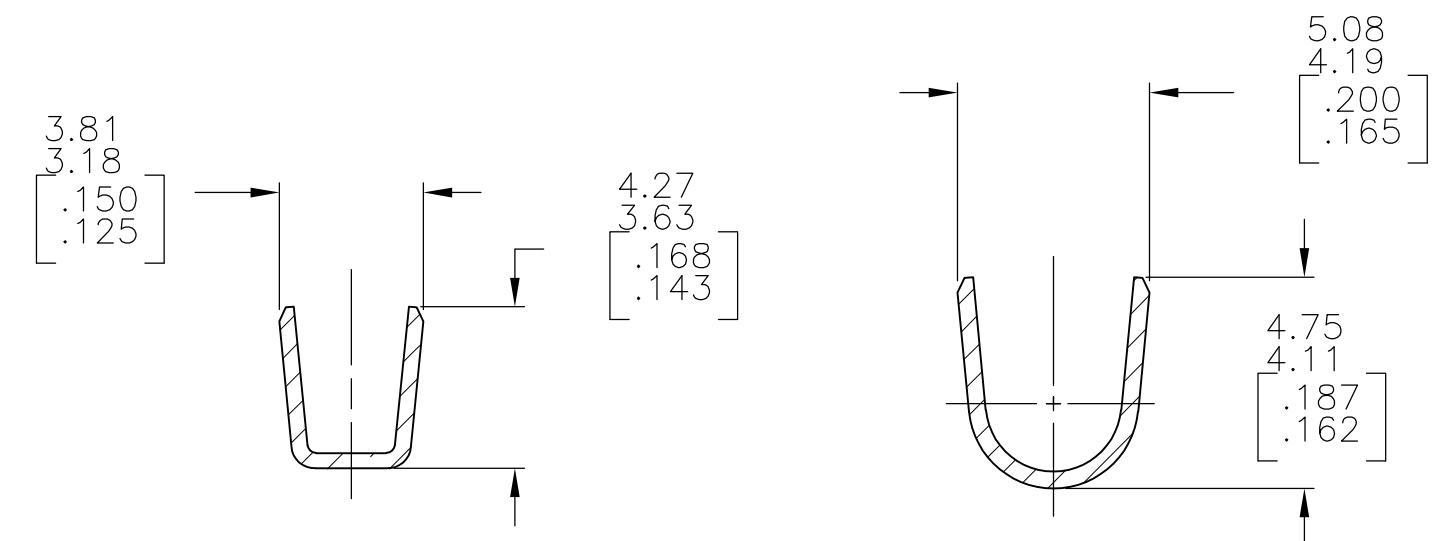
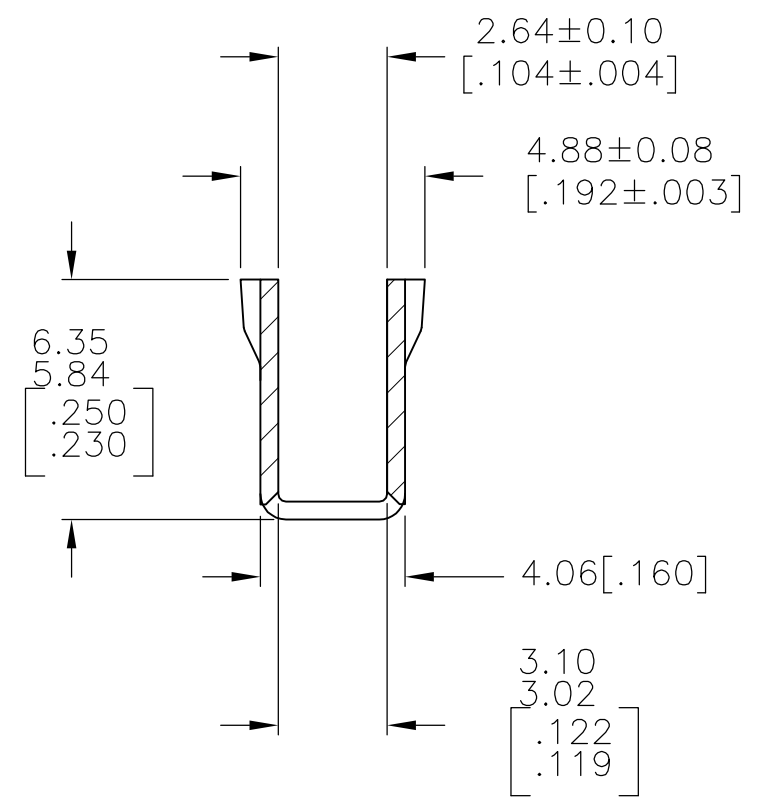
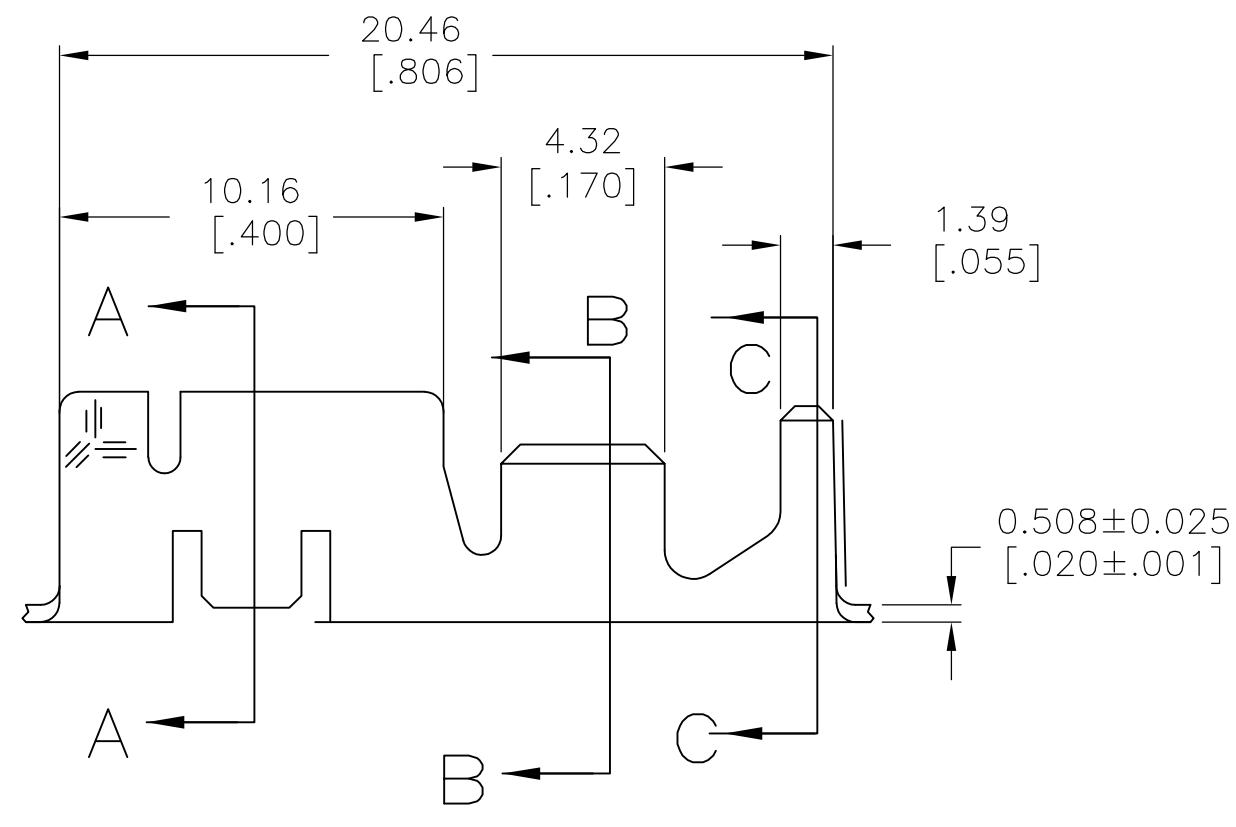
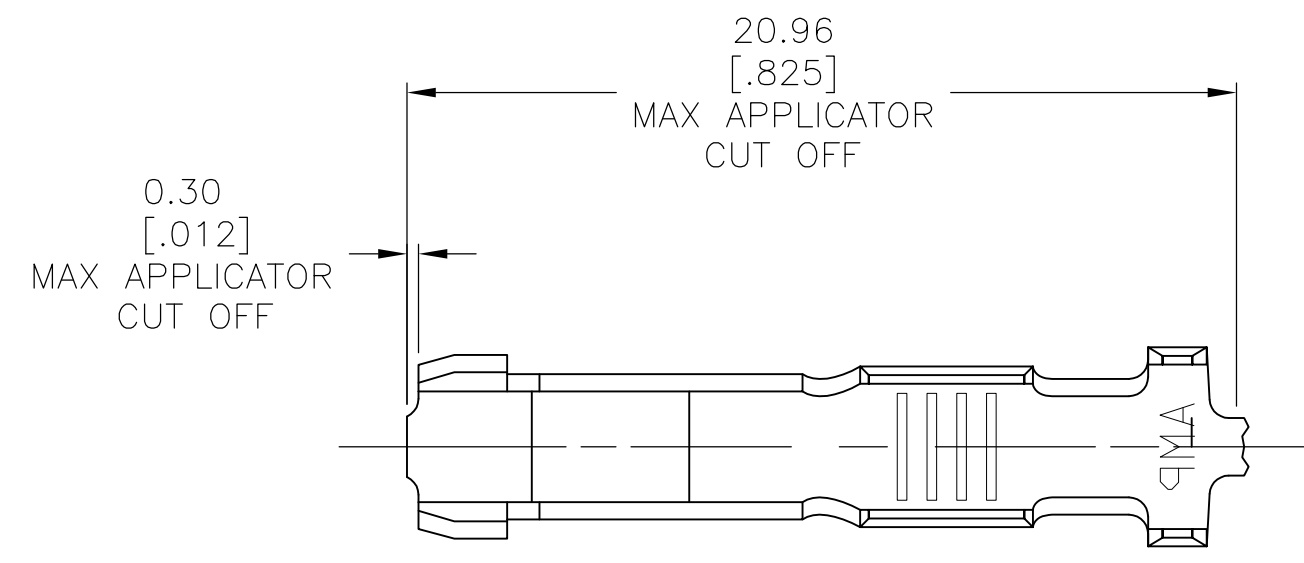

- 1 CONTINUOUS STRIP ON REELS WITH TERMINALS LOCATED ON 22.61[.890] CENTERS
- 2 SPECIAL PACKAGING
- 3 PREPRODUCTION - FASR REQUIRED.

	FINISH	INSULATION	BARREL DIA	WIRE BARREL RANGE	PART NO
OBSOLETE	TIN PLATE	3.30[.130] MAX	0.75-1.5mm ² [#18-#16]AWG	2	62244-6
	-	3.30[.130] MAX	0.75-1.5mm ² [#18-#16]AWG	3	62244-5
	TIN PLATE	3.30[.130] MAX	0.75-1.5mm ² [#18-#16]AWG		62244-3
	-	-	-		-
	-	-	-		-

TYPE	WIDTH	STRIP LENGTH ±0.38 [±.015]	TYPE	WIDTH	±0.051±[.002] HEIGHT	WIRE
F OR O	3.94 [.155]	6.22 [.245]	F	2.79 [.110]	2.01 [.079]	1.5mm ² [16]
					1.85 [.073]	.75mm ² [18]
INSUL BARREL CRIMP			WIRE BARREL CRIMP			

THIS DRAWING IS A CONTROLLED DOCUMENT.

DIMENSIONS: mm [INCHES]	TOLERANCES UNLESS OTHERWISE SPECIFIED:	DWN DK SCHRUM 2/20/90	 TE Connectivity
	0 PLC ± -	CHK MS FEHER 2/22/90	
	1 PLC ± -	APVD T L SHUTTER 3/5/90	
	2 PLC ± -	PRODUCT SPEC 108-2008	
	3 PLC ± 0.38 [.015]	APPLICATION SPEC 114-2019	NAME RECEPTACLE, CLUSTER PIN, 3.18[.125] DIA
	4 PLC ± -	WEIGHT -	SIZE A2
	ANGLES ± -	CUSTOMER DRAWING	CAGE CODE 00779
MATERIAL H03 TIN-BRASS	FINISH SEE TABLE	SCALE 5:1	DRAWING NO C=62244
		SHEET 1 of 1	RESTRICTED TO -
		REV AB	