

LOC		DIST		REVISIONS			
P	LTR	DESCRIPTION	DATE	DMN	APVD		
C		REVISED PER EC 0512-0278-05	21JUL05	JDP	RW		
C1		REVISED PER ECO-10-000444	16JAN10	KK	AEG		

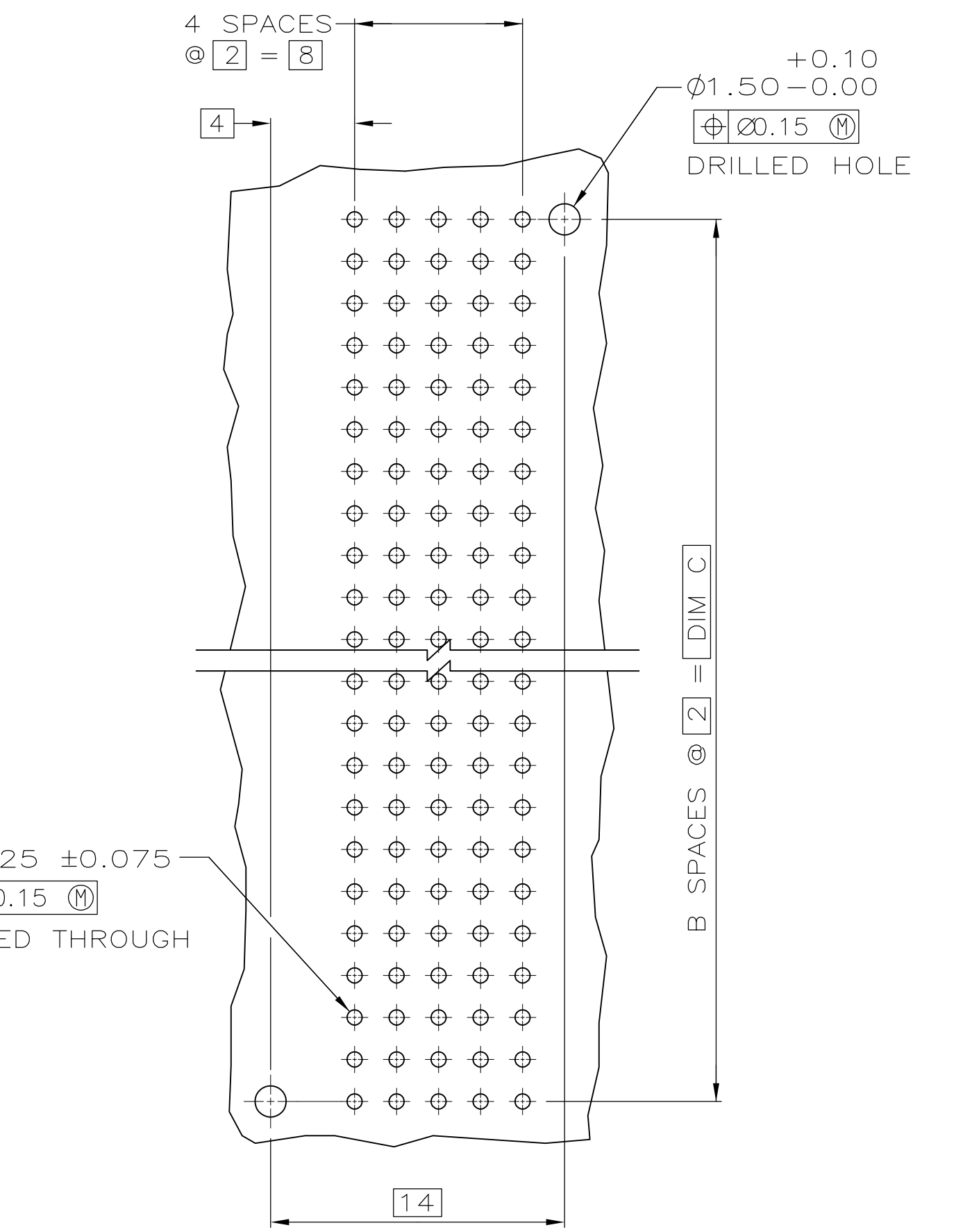

RECOMMENDED CIRCUIT PATTERN (COMPONENT SIDE)

- ① HOUSING MATERIAL: LIQUID CRYSTAL POLYMER
COLOR: NATURAL.
- ② CONTACT MATERIAL: PHOSPHOR BRONZE
- ③ CONTACT FINISH:(A)
UNDERPLATE (ENTIRE CONTACT):
0.00127 MIN NICKEL PER SAE-AMS-QQ-N-290
ON MATING SURFACES:
CONFORMS TO ALL TESTING SPECIFIED FOR TELCORDIA
UNCONTROLLED ENVIRONMENT.
ON LEADS:
0.00381 MIN MATTE TIN PER ASTM B 545 OVER UNDERPLATE.
LUBRICATION (MIN MATING SURFACES):
SURFACE CONDITIONER AFTER PLATING.
- ④ PART MARKING LOCATED APPROXIMATELY AS SHOWN.
- ⑤ OBSOLETE PARTS: OBSOLETE CIS STREAMLINING PER D.RENAUD/D.SINISI

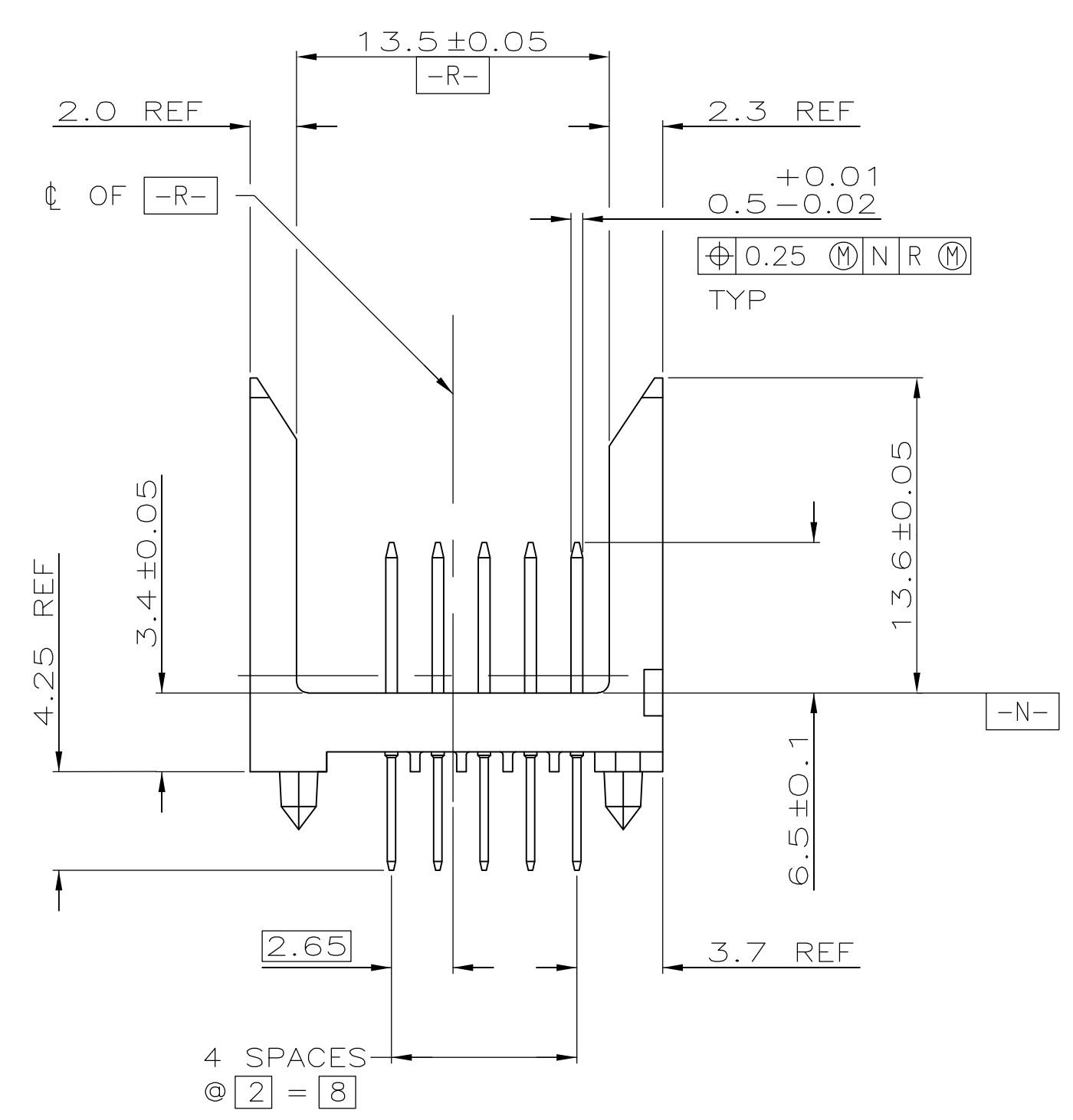
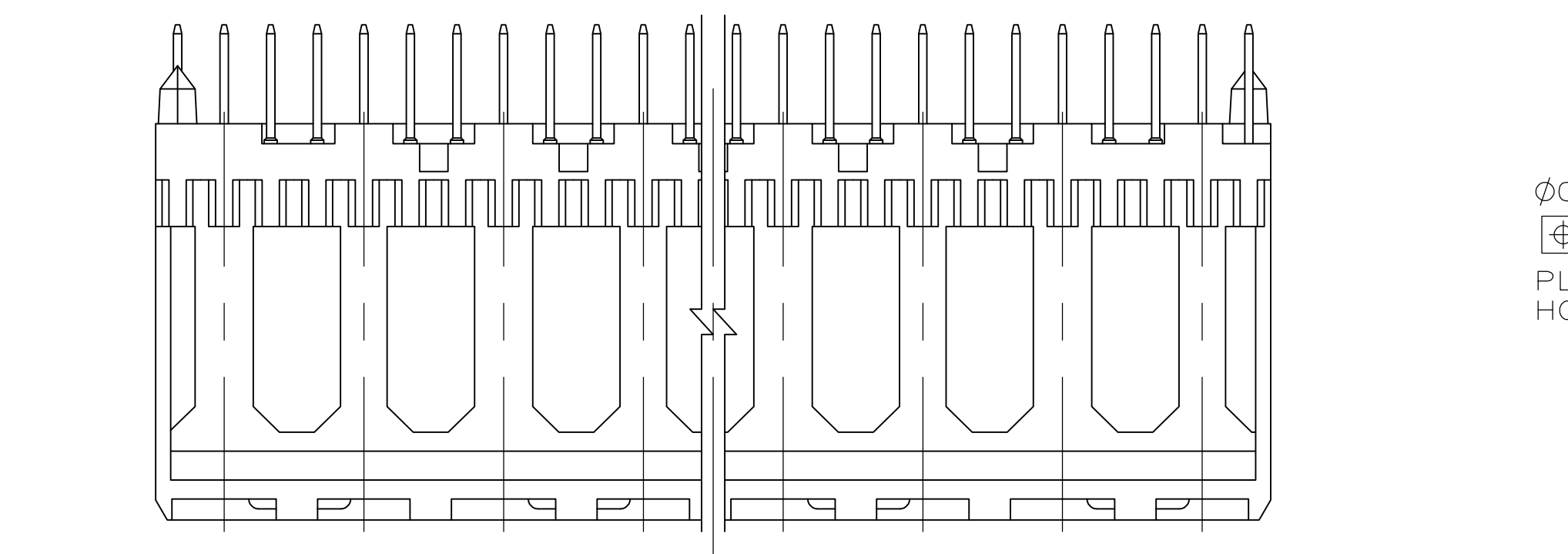
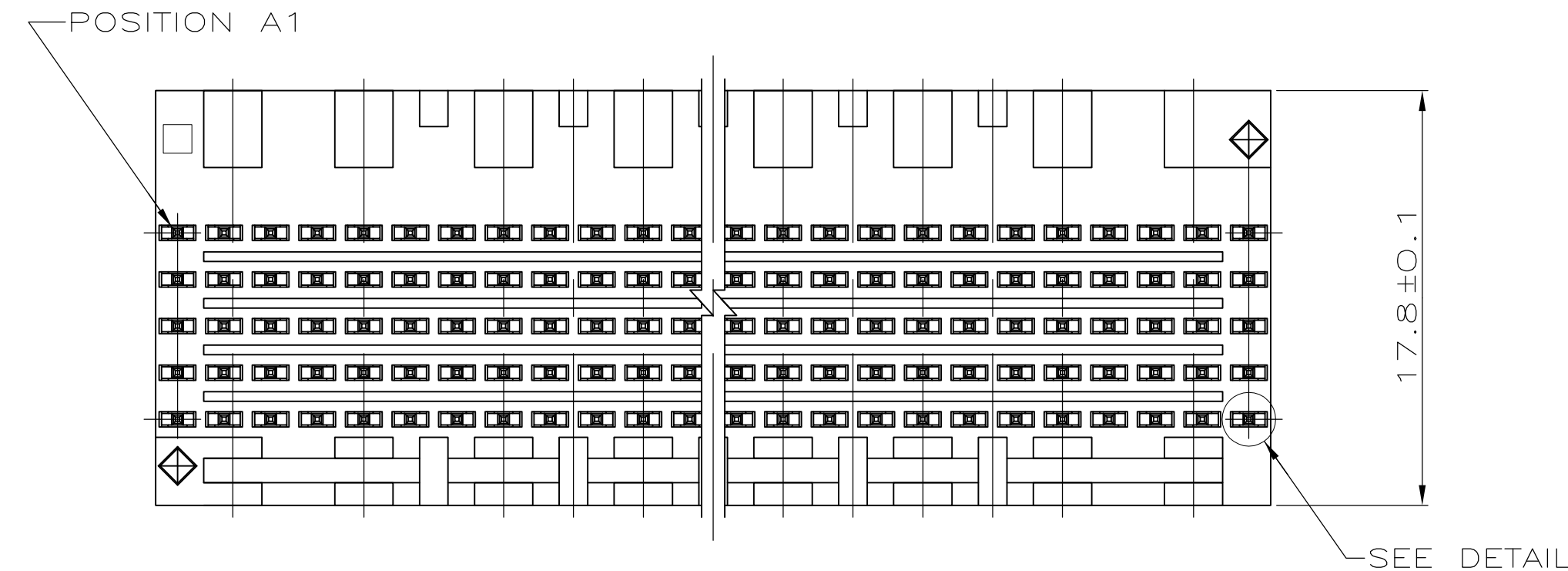
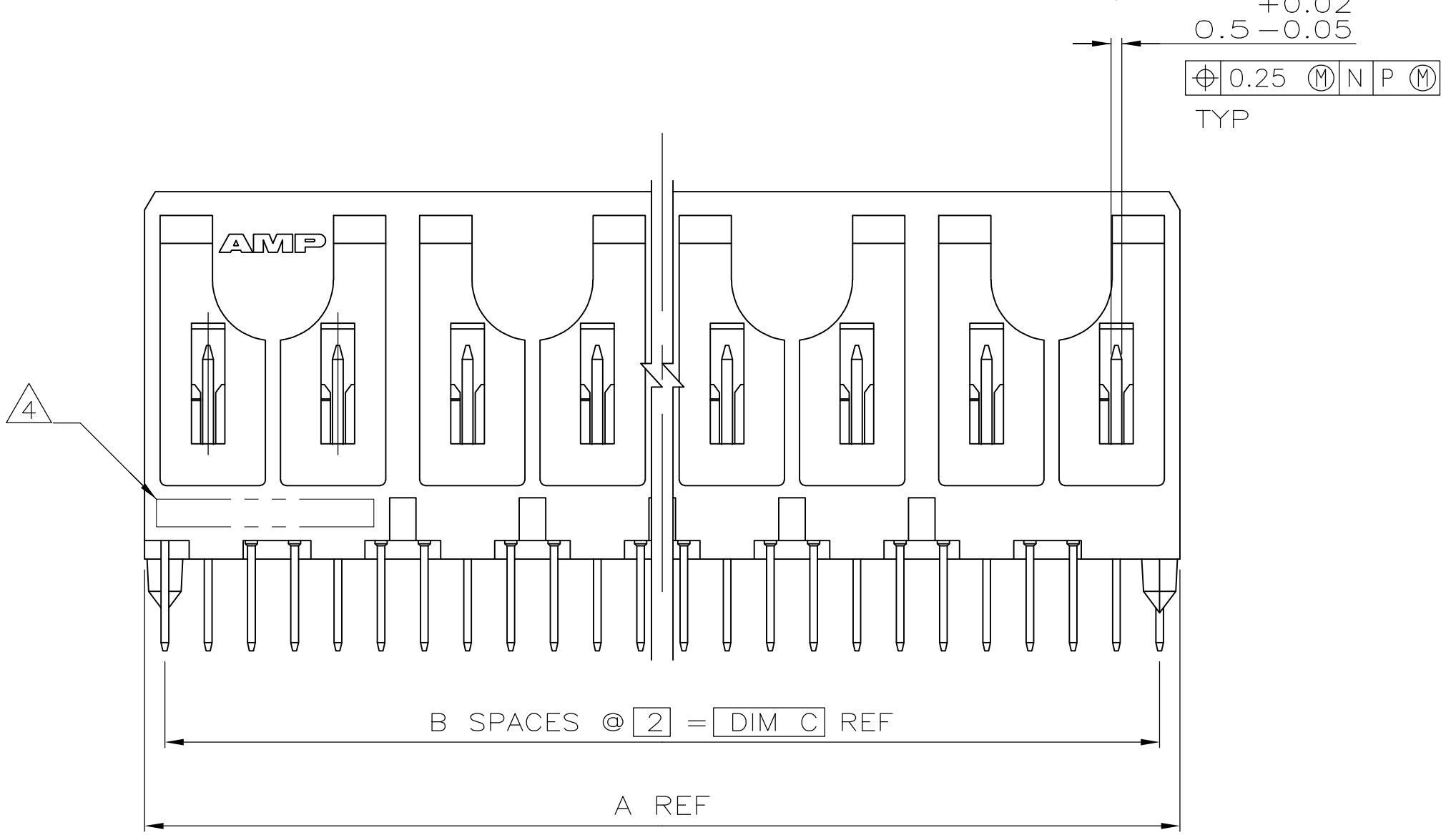
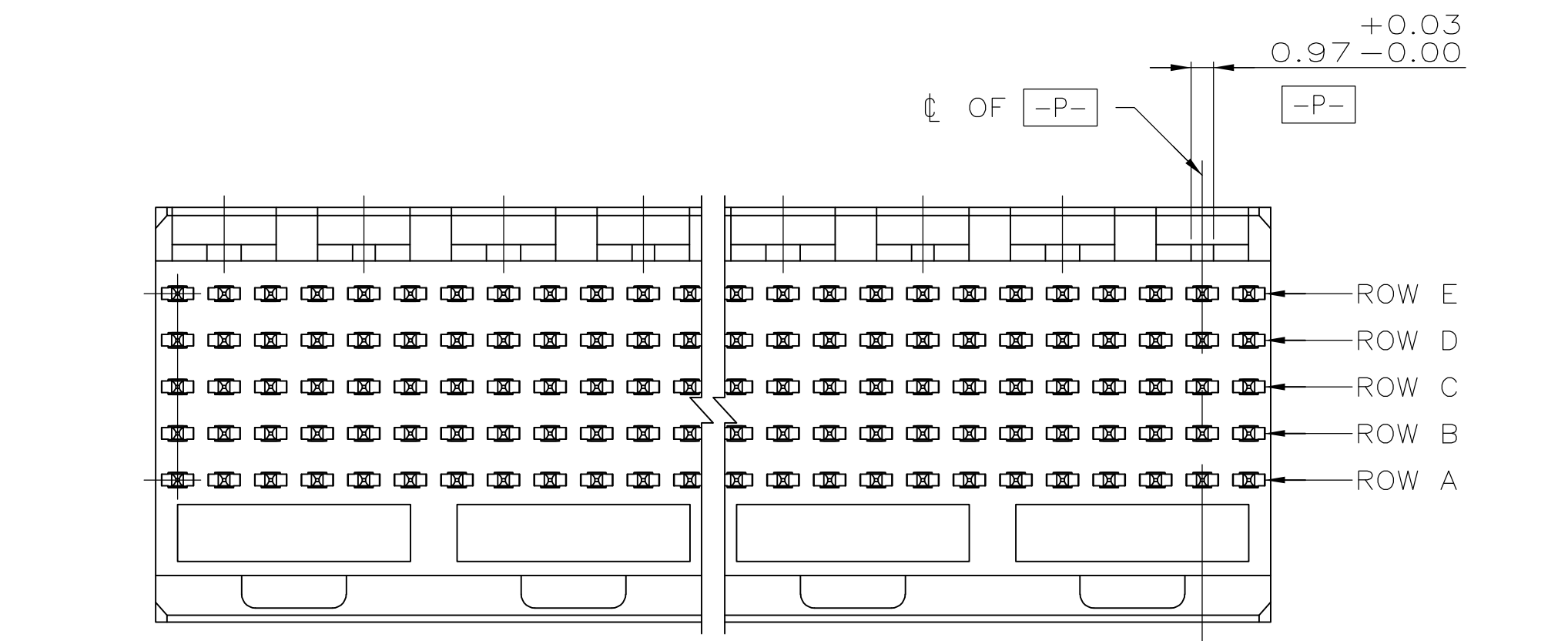
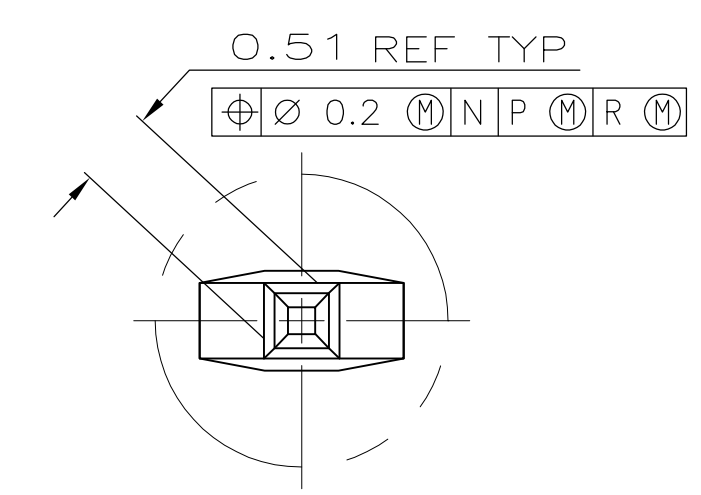

DETAIL Z
SCALE 20:1

⑤ OBSOLETE	130	65	131.88	③	330	-1-5223000-1
OBSOLETE	118	59	119.88	③	300	1-5223000-0
OBSOLETE	106	53	107.88	③	270	-5223000-9
	94	47	95.88	③	240	5223000-8
OBSOLETE	82	41	83.88	③	210	-5223000-7
OBSOLETE	70	35	71.88	③	180	-5223000-6
	58	29	59.88	③	150	5223000-5
OBSOLETE	46	23	47.88	③	120	-5223000-4
	34	17	35.88	③	90	5223000-3
	22	11	23.88	③	60	5223000-2
	10	5	11.88	③	30	5223000-1
	C	B	A	FINISH	NO OF SIGNAL POSN	PART NUMBER

THIS DRAWING IS A CONTROLLED DOCUMENT.

DMN: B. MCMASTER 19NOV04
 CHK: R. WERTZ 19NOV04
 APVD: R. WERTZ 19NOV04

Tyco Electronics Corporation
 Harrisburg, Pa 17105-3608

ASSEMBLY, PIN, SIGNAL, VERTICAL,
 Z-PACK 2mm FB, 5 ROW,
 SOLDER LEAD

SIZE: A1
 CAGE CODE: 00779
 DRAWING NO: 5223000

RESTRICTED TO: C1

CUSTOMER DRAWING SCALE: 4:1 SHEET: 1 of 1 REV: C1