

THIS DRAWING IS UNPUBLISHED. RELEASED FOR PUBLICATION

© COPYRIGHT 19 BY AMP INCORPORATED, HARRISBURG, PA. ALL INTERNATIONAL RIGHTS RESERVED. AMP PRODUCTS MAY BE COVERED BY U.S. AND FOREIGN PATENTS AND/OR PATENTS PENDING.

REVISIONS		DATE	APPROV
1	A	2/26/82	SS/C
2			
3			

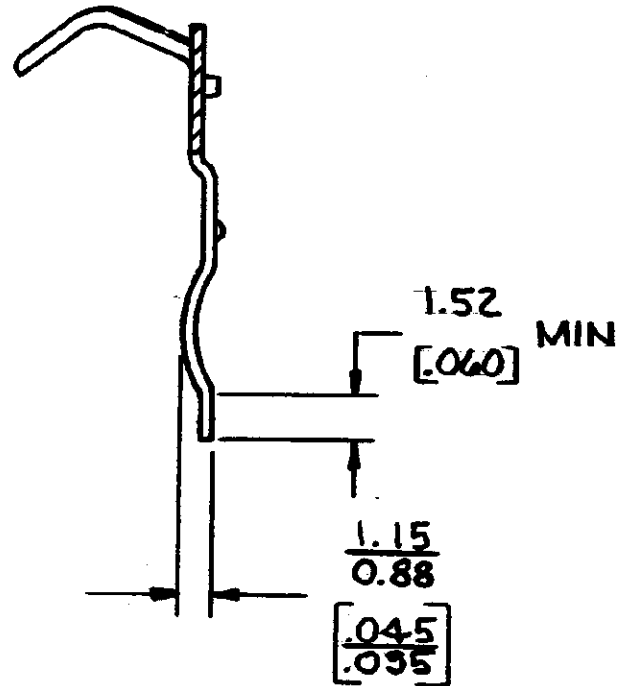
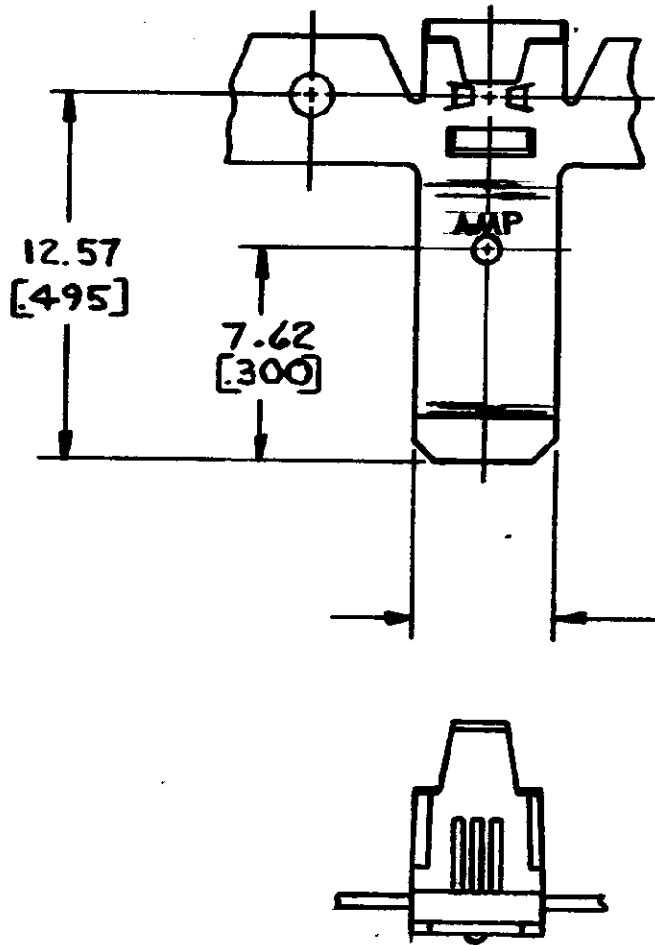

- 1. DIMS. IN BRACKETS ARE IN INCH
- 2. CONTINUOUS STRIP ON REELS

4.83
4.67
[.190]
[.184]

1.15
0.88
[.045]
[.035]

METRIC

UNLESS OTHERWISE SPECIFIED DIMENSIONS ARE IN INCHES. MM TOLERANCES ON: DECIMALS ±0.38 [05] ANGLES ±		CONTRACT NO		0.5-2.0 mm ² [*20-*14]		63182-	
MATERIAL 0.46 [018] PHOS BRONZE		CHK G. Ketter 11/20/81		WIRE RANGE		PART NO	
FINISH NONE		APPD D. Schwank 11-20-81		AMP AMP INCORPORATED Harrisburg, Pa.		NAME	
OTHER APPD		APPD W. Esantun 11/23/81		BRUSH CONTACT TAB-LOK (RIGHT-HAN)		SIZE	
		DSGN APPD		B		FSCM NO	
		OTHER APPD		00779		DRAWING NO	
				63182		SCALE	
						SHEET	