

STAND OFFS CAN BE EITHER ROUND OR SQUARE.

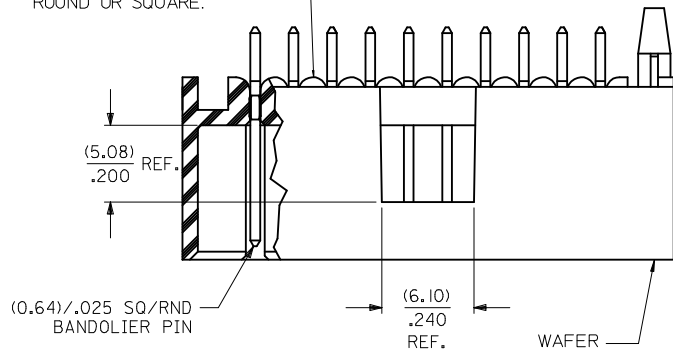

NOTES:

1. MATERIAL: WAFER - GLASS FILLED LIQUID CRYSTAL POLYMER, UL 94V-0, COLOR: BLACK, PIN: COPPER ALLOY.
2. PLATING: TIN
 TIN(Sn) ALLOY OVER ENTIRE PIN: THICKNESS = (3.81 MICROMETER)/ 150 MICROINCH MINIMUM;
 NICKEL (Ni) UNDERPLATE OVER ENTIRE PIN;
 15 GOLD SELECTIVE GOLD (Au) IN THE CONTACT AREA: THICKNESS = (0.38 MICROMETER)/ 15 MICROINCH MINIMUM;
 SELECTIVE TIN (Sn) ALLOY IN THE PC TAIL AREA: THICKNESS = (1.91 MICROMETER)/ 75 MICROINCH MINIMUM;
 NICKEL (Ni) UNDERPLATE OVER ENTIRE PIN;
 30 GOLD SELECTIVE GOLD (Au) IN THE CONTACT AREA: THICKNESS = (0.76 MICROMETER)/ 30 MICROINCH MINIMUM;
 SELECTIVE TIN (Sn) ALLOY IN THE PC TAIL AREA: THICKNESS = (1.91 MICROMETER)/ 75 MICROINCH MINIMUM;
 NICKEL (Ni) UNDERPLATE OVER ENTIRE PIN.
 * THE PRIMARY SHIPPING CARTON WILL BE LABELED "COMPLIANT TO RoHS DIRECTIVE 2002/95/EC AND ELV ANNEX II OF DIRECTIVE 2000/53/EC". CARTONS WITHOUT THIS LABEL MAY CONTAIN PRODUCT WITH LEAD.
3. PRODUCT SPECIFICATION: PS-70567.
4. PACKAGING: SEE CHARTS
5. PIN PUSHOUT FORCE: 4 LBS. MIN. IN DIRECTION INDICATED.
6. FOR ILLUSTRATION PURPOSES, 20 (DUAL 10) CIRCUIT SIZE IS SHOWN.
7. PINS MUST MEET SOLDERABILITY SPEC. SMS-152.
 EXCEPT VOIDS ARE PERMISSIBLE AT BANDOLIER PIN FAYING SURFACE. (APPROX. (0.64)/.025 LNG X (0.15)/.006 WD. REF.) - 2 LOCATIONS
8. NO FEATURES WHICH RISE ABOVE THE PCB SURFACE ALLOWED IN THIS AREA.
9. THIS PART CONFORMS TO CLASS B REQUIREMENTS OF COSMETIC SPEC PS-45499-002.

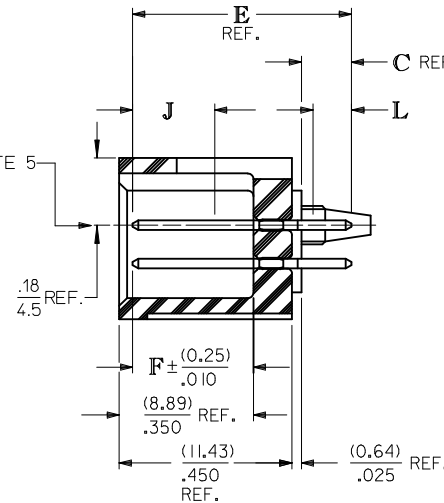
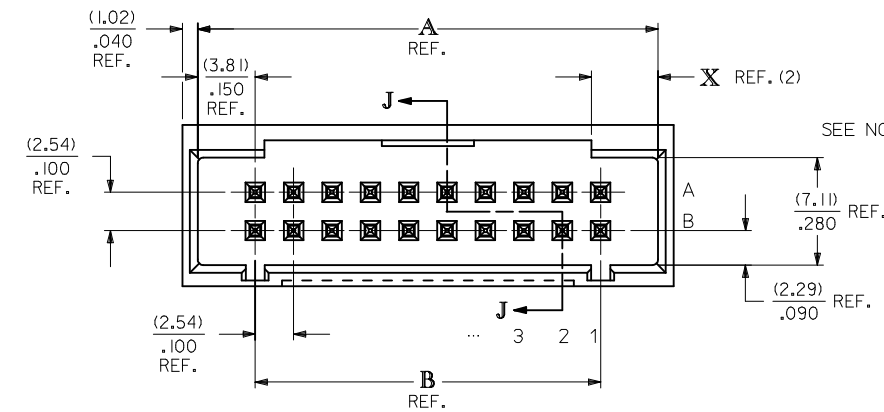

SECTION J-J

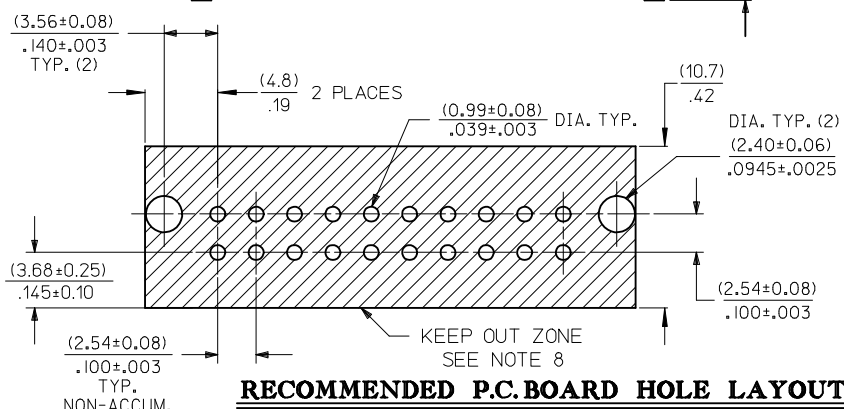
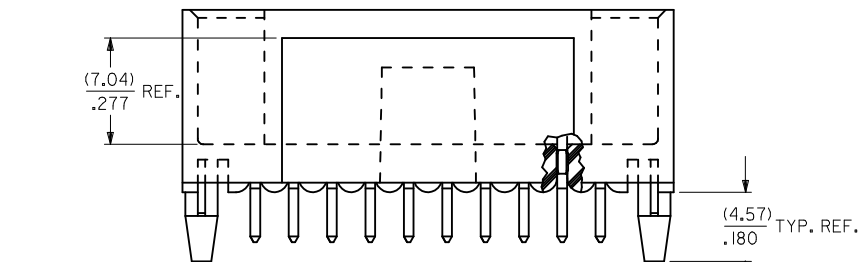

RECOMMENDED P.C. BOARD HOLE LAYOUT

CKT. SIZE	DIM. A REF.		DIM. B REF.		DIM. X REF.	
	(MM)	INCH	(MM)	INCH	(MM)	INCH
6	(12.70)	.500	(5.08)	.200	(3.18)	.125
8	(15.24)	.600	(7.62)	.300	(4.42)	.174
10	(17.78)	.700	(10.16)	.400	(4.42)	.174
12	(20.32)	.800	(12.70)	.500	(4.42)	.174
14	(22.86)	.900	(15.24)	.600	(4.42)	.174
16	(25.40)	1.000	(17.78)	.700	(4.42)	.174
18	(27.94)	1.100	(20.32)	.800	(4.42)	.174
20	(30.48)	1.200	(22.86)	.900	(4.42)	.174
22	(33.02)	1.300	(25.40)	1.000	(4.42)	.174
24	(35.56)	1.400	(27.94)	1.100	(4.42)	.174
26	(38.10)	1.500	(30.48)	1.200	(4.42)	.174
28	(40.64)	1.600	(33.02)	1.300	(4.42)	.174
30	(43.18)	1.700	(35.56)	1.400	(4.42)	.174
32	(45.72)	1.800	(38.10)	1.500	(4.42)	.174
34	(48.26)	1.900	(40.64)	1.600	(4.42)	.174
36	(50.80)	2.000	(43.18)	1.700	(4.42)	.174
40	(55.88)	2.200	(48.26)	1.900	(4.42)	.174
42	(58.42)	2.300	(50.80)	2.000	(4.42)	.174
44	(60.96)	2.400	(53.34)	2.100	(4.42)	.174
46	(63.50)	2.500	(55.88)	2.200	(4.42)	.174
48	(66.04)	2.600	(58.42)	2.300	(4.42)	.174
50	(68.58)	2.700	(60.96)	2.400	(4.42)	.174
52	(71.12)	2.800	(63.50)	2.500	(4.42)	.174
54	(73.66)	2.900	(66.04)	2.600	(4.42)	.174
56	(76.20)	3.000	(68.58)	2.700	(4.42)	.174
58	(78.74)	3.100	(71.12)	2.800	(4.42)	.174
60	(81.28)	3.200	(73.66)	2.900	(4.42)	.174
62	(83.82)	3.300	(76.20)	3.000	(4.42)	.174
64	(86.36)	3.400	(78.74)	3.100	(4.42)	.174
66	(88.90)	3.500	(81.28)	3.200	(4.42)	.174
68	(91.44)	3.600	(83.82)	3.300	(4.42)	.174
70	(93.98)	3.700	(86.36)	3.400	(4.42)	.174
72	(96.52)	3.800	(88.90)	3.500	(4.42)	.174

2	G
1	H
SHT	REV

MODIFIED NOTES EC NO: UCP2009-0336 DRAWN: JLOSTER/ER 2008/09/23 CHKD: JBEL 2008/09/24 APPR: FSM/TH 2008/09/25	QUALITY SYMBOLS ▽=0 ▽=0	GENERAL TOLERANCES (UNLESS SPECIFIED) mm INCH 4 PLACES ± --- ± --- 3 PLACES ± --- ± .005 2 PLACES ± 0.13 ± .01 1 PLACE ± 0.25 ± --- ANGULAR ± 1/2°	DIMENSION STYLE MM/IN DRAWN BY DATE SMR 1993/11/10 CHECKED BY DATE SMR 1993/11/10 APPROVED BY DATE	SCALE 4:1 DESIGN UNITS INCH THIRD ANGLE PROJECTION	
		DRAFT WHERE APPLICABLE MUST REMAIN WITHIN DIMENSIONS	MATERIAL NO. SEE TABLE	DOCUMENT NO. SDA-70568-****	SHEET NO. 1 OF 2
		MOLEX MOLEX INCORPORATED			
		THIS DRAWING CONTAINS INFORMATION THAT IS PROPRIETARY TO MOLEX INCORPORATED AND SHOULD NOT BE USED WITHOUT WRITTEN PERMISSION			

