

REVISIONS				
REV	ECN, ERN NO.	DATE	REV BY	APPRD.
A	PROPOSAL	OCT 9/2006		L.CHAN
B	OPERATION NOTE ADDED	NOV14/2006	Jack Wang	L.CHAN

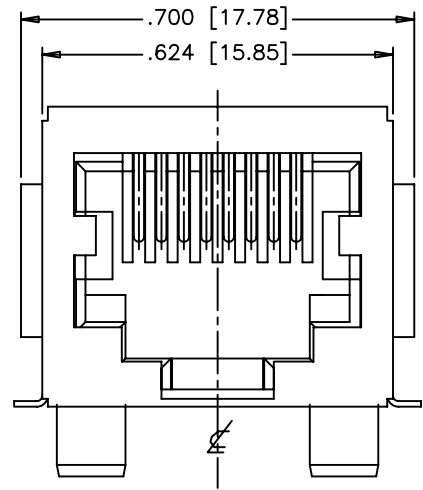

FRONT VIEW

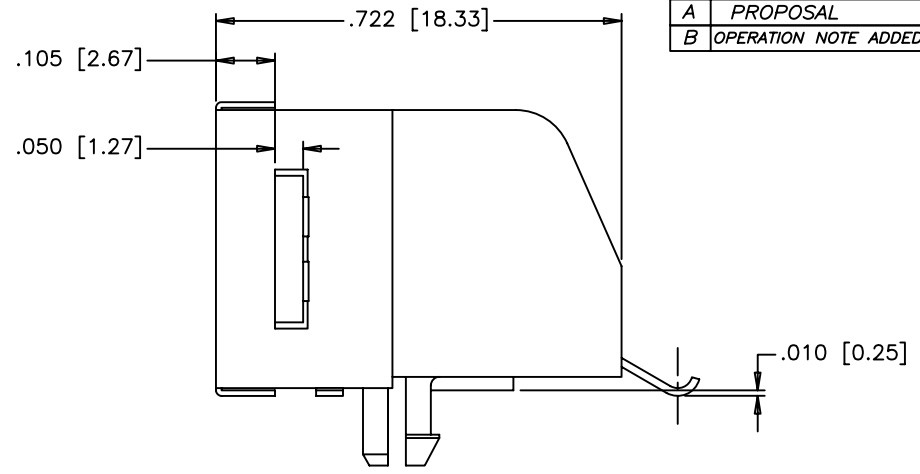

SIDE VIEW

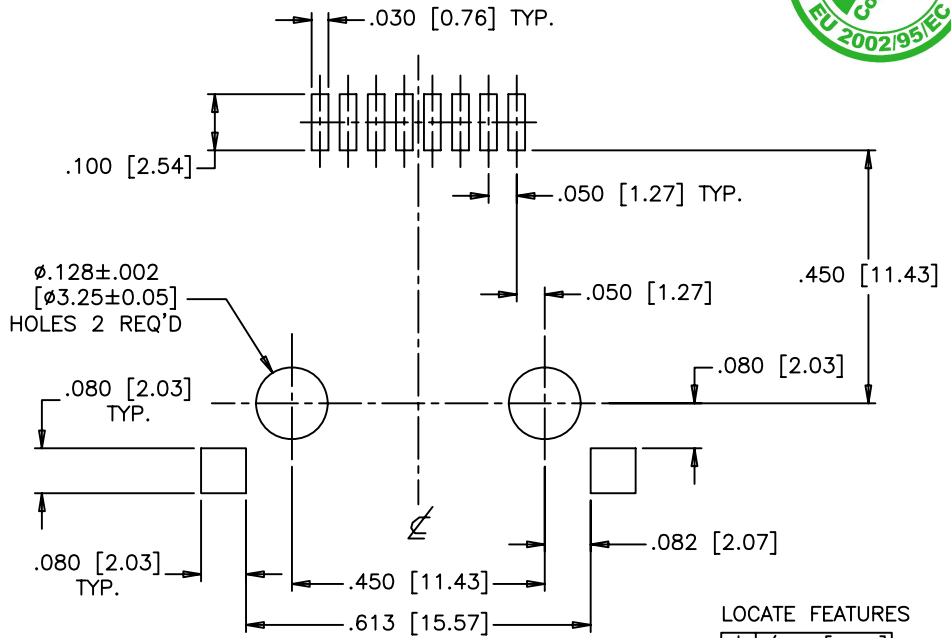

RECOMMENDED P.C.B. LAYOUT
(COMPONENT SIDE OF BOARD)

LOCATE FEATURES
 $\varnothing \phi.005 [0.13]$
 ALL POSITIONS
 ARE BASIC

MATERIALS:

- HOUSING: HIGH TEMPERATURE THERMOPLASTIC
FLAMMABILITY RATING UL94V-0
COLOR: BLACK
- CONTACTS: COPPER ALLOY
- PLATING: MATING AREA: SELECTIVELY PLATED GOLD—PER PART NUMBER OPTIONS
50 μ " MIN. NICKEL OVERALL
80 μ " MIN. MATTE TIN OVER TAIL
- SHIELD: COPPER ALLOY
NICKEL PLATED
- RECOMMENDED SOLDERING TEMPERATURE:
REFLOW SOLDERING AT 260°C MAXIMUM FOR 5 SEC MAXIMUM

AMPHENOL PART NUMBER: RJE07-188-3X20

- GOLD PLATING
- 1 = 06 μ "
 - 2 = 15 μ "
 - 3 = 30 μ "
 - 4 = 50 μ "

DRAWN	JACK WANG	DATE	OCT 9/06
DESIGNED			
CHECKED	CHIGOW XU	DATE	OCT 9/06
I. E. APPRD.			
Q. A. APPRD.			
DWG. APPRD.			
ENG. REL. NO.			
REF.			
DIMENSIONS ARE IN	CODE ID. NO.		
inches (mm)	03554		

Amphenol Canada Corp.

TITLE
 RJE07 SERIES ASSEMBLY, SIDE ENTRY, SURFACE MOUNT,
 WITH PARTIAL SHIELD HAVING SURFACE MOUNT TABS
 (WITH FLANGE, WITHOUT KEY)—RoHS COMPLIANT

DWG	DRAWING NO.	REV.
	P-RJE07-188-3X20	B

SCALE	WT.	SURF.	SHEET 1 OF 1
-------	-----	-------	--------------

THIS DOCUMENT CONTAINS PROPRIETARY INFORMATION AND SUCH INFORMATION
 MAY NOT BE DISCLOSED TO OTHERS FOR ANY PURPOSE OR USED FOR MANUFACTURING
 PURPOSES WITHOUT WRITTEN PERMISSION FROM AMPHENOL CANADA CORP.