

THIS DRAWING AND THE SUBJECT MATTER SHOWN THEREON ARE CONFIDENTIAL AND THE PROPERTY OF BEL/STEWART/TRP CONNECTOR AND SHALL NOT BE REPRODUCED, COPIED, OR USED IN ANY MANNER WITHOUT THE WRITTEN CONSENT OF TRP CONNECTOR.

PRODUCT MAY BE PROTECTED BY ONE OR MORE OF THE FOLLOWING US PATENTS:
 5736910 5939955 6425781 6428361 6554638 6840817 7123117
 7429195 7717749 7808751 6217391 6149050 7924130

REVISIONS					
#	REV	DESCRIPTION	DATE	BY	APP
1	G	EC-1411035 COMPANY LOGO CHANGE	24DEC2014	ST	TL

MECHANICAL:

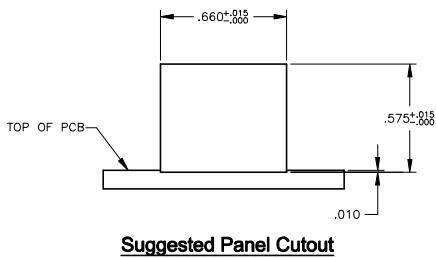
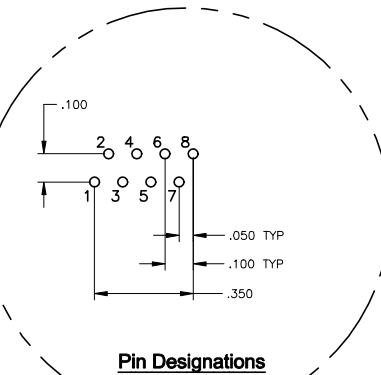
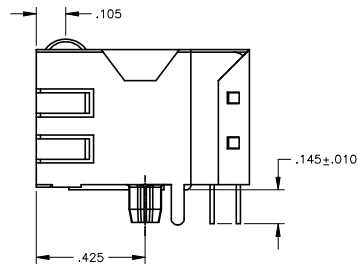
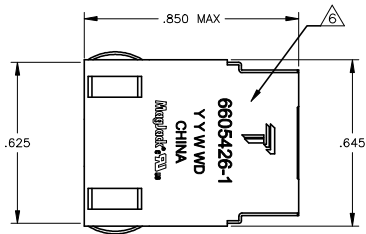
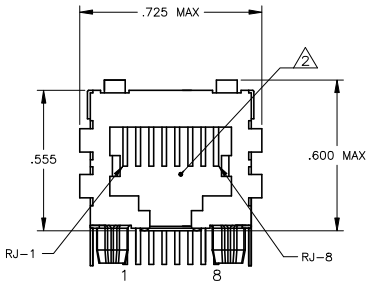

426P1 SERIES MAGNETIC CIRCUIT

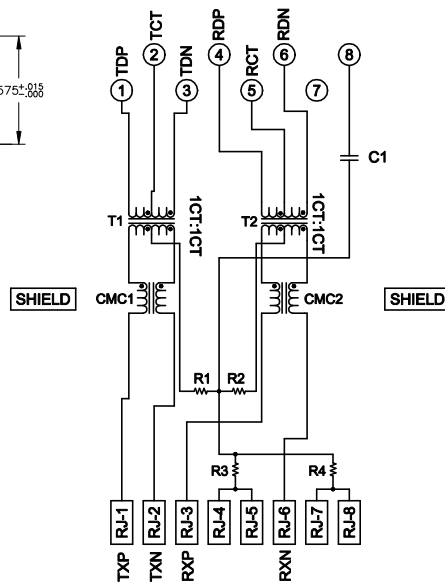

C1 = 1000 pF, 2kV CAPACITOR
 R1-R4 = 75 OHMS, 1/16 W RESISTORS

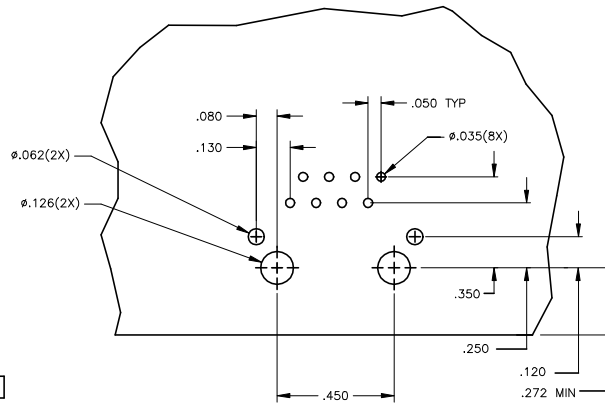

1. MATERIALS:
 HOUSING - THERMOPLASTIC PET POLYESTER FLAMMABILITY RATING UL 94V-0.
 SHIELD - .010" THICK, C26800 BRASS PREPLATED WITH 30μINCH MIN SEMI-BRIGHT NICKEL. SOLDER TABS POST DIPPED WITH 100μINCH MIN SAC SOLDER.
 MOD JACK CONTACTS - 0.0157 X 0.018" PHOSPHOR BRONZE, 50μINCH MIN OVERALL NICKEL UNDERPLATE WITH SELECT 50μINCH MIN HARD GOLD FINISH PLATE.
 SOLDER TAILS WITH 100μINCH MIN MATTE TIN AND/OR SAC SOLDER DIP.
- ⚠ RJ45 JACK CAVITY CONFORMS TO FCC RULES AND REGULATIONS PART 68, SUB PART F.
- ⚠ MAGNETICS
 -IMPEDANCE: 100 OHMS
 -TURNS RATIO (CHIP:CABLE): TX = 1:1, RX = 1:1
 -OPEN CIRCUIT INDUCTANCE (OCL): 350μH MIN @100kHz, 0.1VRMS,
 8mA DC BIAS FROM 0°C TO 70°C, TX AND RX
 -PERFORMANCE @ 25°C:
 INSERTION LOSS (IL): 1.1dB MAX FROM 0.5MHz TO 100MHz
 RETURN LOSS (RL): 18dB MIN FROM 0.5MHz TO 30MHz
 18-20LOG(f/30)dB MIN FROM 30.1MHz TO 60MHz
 12dB MIN FROM 60.1MHz TO 80MHz
 CROSSTALK ATTENUATION: 35dB MIN FROM 0.5MHz TO 4.0MHz
 33-20×LOG(f/50)dB MIN FROM 4.0.1MHz TO 100MHz
 COMMON MODE REJECTION RATIO (CMRR): 30dB MIN FROM 0.5MHz TO 100MHz
 -ISOLATION VOLTAGE: 2250VDC (MAX) FOR 60 SECONDS WITH A RISE TIME OF 500V/SEC.
4. OPERATING TEMPERATURE: FROM 0° TO +70°C.
- ⚠ INDICATED CONNECTIONS ARE FOR NIC CONFIGURATION. THE MAGNETICS ARE SYMMETRICAL, AND THEREFORE SUPPORT AUTO-MDI/MDIX.
- ⚠ TRP CONNECTOR LOGO, PART NUMBER, DATE CODE, COUNTRY OF ORIGIN AND AGENCY APPROVAL MARKING IN APPROXIMATE LOCATION SHOWN.
7. THE PART IS RECOMMENDED FOR WAVE SOLDERING PROCESS, PREHEAT TEMPERATURE IS 120°C TO 160°C, 120 SECONDS TO 180 SECONDS, PEAK WAVE SOLDERING TEMPERATURE IS 260°C MAX, 10 SECONDS MAX.

6605426-1
 PART NUMBER

THIS DRAWING IS A CONTROLLED DOCUMENT. CHANGES BY G. ATTADIA - DOKCS				DONGGUAN CHINA o tai gmb	
DIMENSIONS: INCHES MILLIMETERS	DIMENSIONS: INCHES MILLIMETERS	DIMENSIONS: INCHES MILLIMETERS	DIMENSIONS: INCHES MILLIMETERS	DIMENSIONS: INCHES MILLIMETERS	DIMENSIONS: INCHES MILLIMETERS
PRODUCT SPEC: 180-2100				CUSTOMER DRAWING	
MAGJACK SINGLE NON-POE				SCALE: NTS	