

CODE No.	CONTACT	A	B	C	D	E	F	G
CL537-0153-9-86	20	7.2	4.5	5.3	5.7	6.6	5.3	8.1
CL537-0155-4-86	30	9.7	7.0	7.8	8.2	9.1	7.8	10.6
CL537-0156-7-86	36	11.2	8.5	9.3	9.7	10.6	9.3	12.1
CL537-0157-0-86	40	12.2	9.5	10.3	10.7	11.6	10.3	13.1
CL537-0159-5-86	50	14.7	12.0	12.8	13.2	14.1	12.8	15.6
CL537-0161-7-86	60	17.2	14.5	15.3	15.7	16.6	15.3	18.1

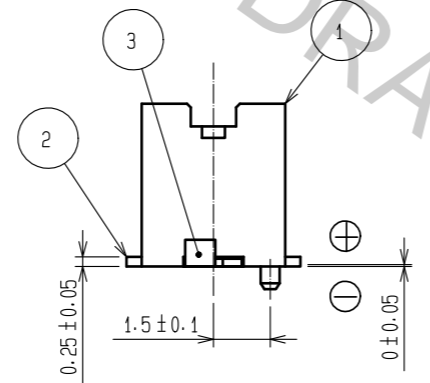

RECOMMEND METAL MASK PATTERN (10:1)

RECOMMENDED PATTERN (10:1)

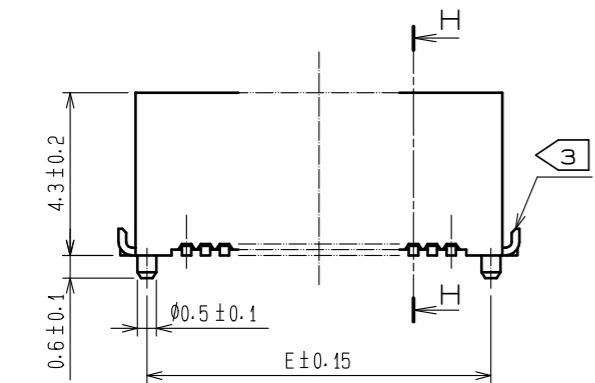
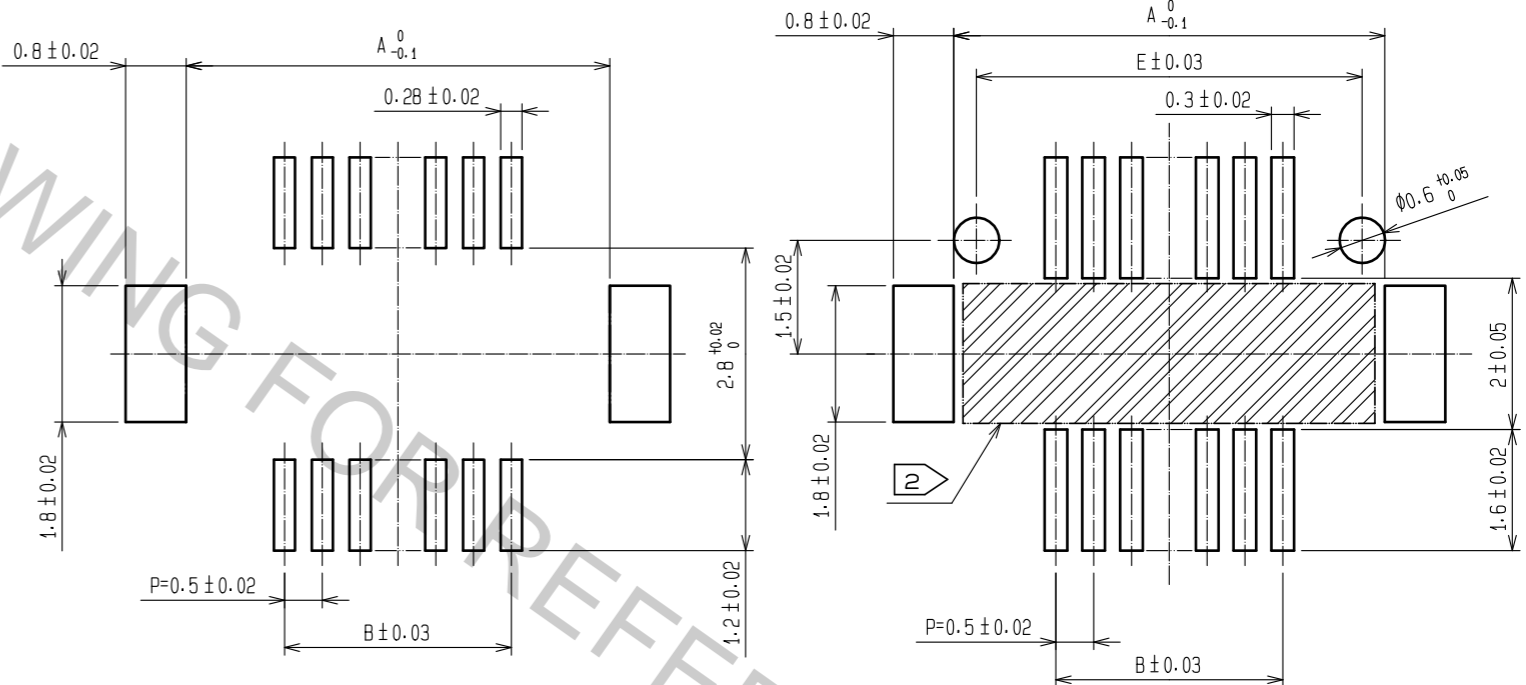

RECOMMENDED THICKNESS OF SOLDER PASTE : 120 μm

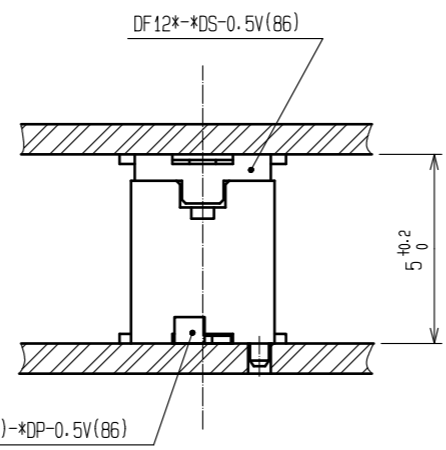
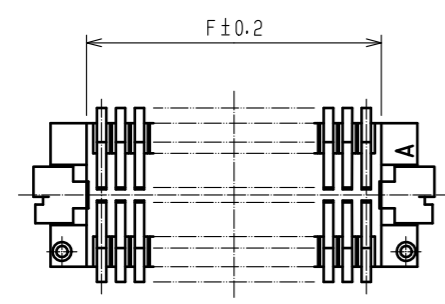

NOTES 1 : LEAD CO-PLANARITY INCLUDING REINFORCED METAL FITTINGS SHALL BE 0.08 mm MAX.  
 2 : IF THERE IS PATTERN ON [Hatched] PART, THERE IS A POSSIBILITY THAT IT WILL MAKE CONTACT WITH THE LEADS.  
 3 : REINFORCED METAL FITTINGS AS FOLLOWS.

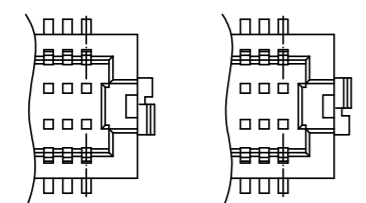

NO.	MATERIAL	FINISH	REMARKS	NO.	MATERIAL	FINISH	REMARKS
2	PHOSPHOR BRONZE		CONTACT AREA:GOLD PLATED 0.2μm min LEAD AREA:GOLD PLATED 0.015μm OTHERS(UNDER PLATING):NICKEL PLATED 2μm min	7	PS		CLEAR (REINFORCEMENT COLLAR)
1	POLYAMIDE		UL94V-0·NATURAL (BEIGE)	6	PS		BLACK (PLASTIC REEL)
				5	POLYESTER		CLEAR (COVER TAPE)
				4	PS		CLEAR (EMBOSSED CARRIER TAPE)
				3	BRASS		TIN PLATED 2μm min (UNDER PLATING):NICKEL 1μm min

UNITS	SCALE	COUNT	DESCRIPTION OF REVISIONS	DESIGNED	CHECKED	DATE
mm	5 : 1	1	DIS-H-00001707	SH. HOSODA	TS. MIYAZAKI	16.06.10

APPROVED	CHECKED	DESIGNED	DRAWN	DATE
KH. IKEDA	TS. MIYAZAKI	YH. MICHIDA	YH. MICHIDA	12.01.11
				12.01.10
				12.01.10
				12.01.10

DRAWING NO.	PART NO.	CODE NO.
EDC3-163514-77	DF12(5.0)-*DP-0.5V(86)	CL537



STYLE AND DIMENSION OF REEL

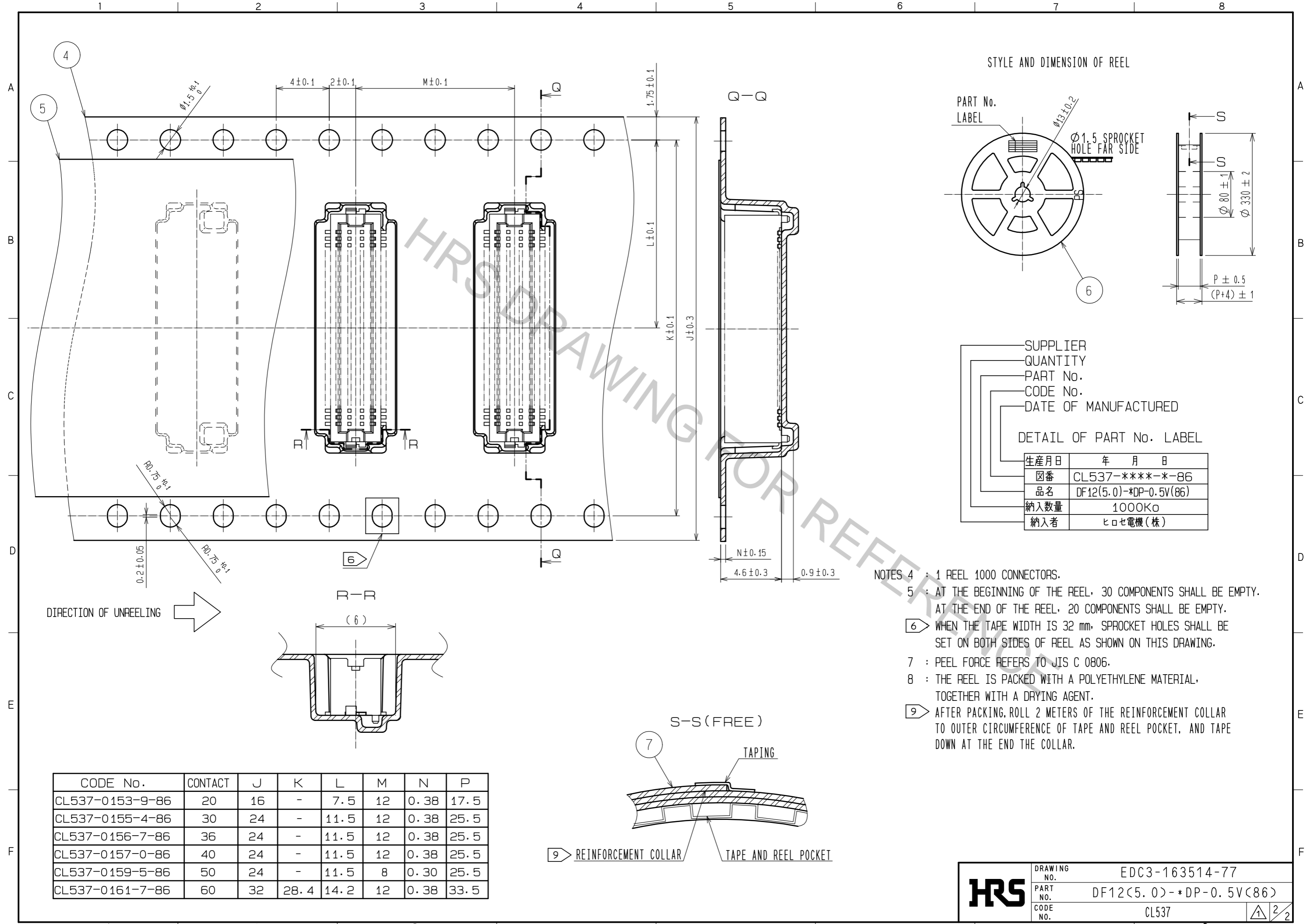

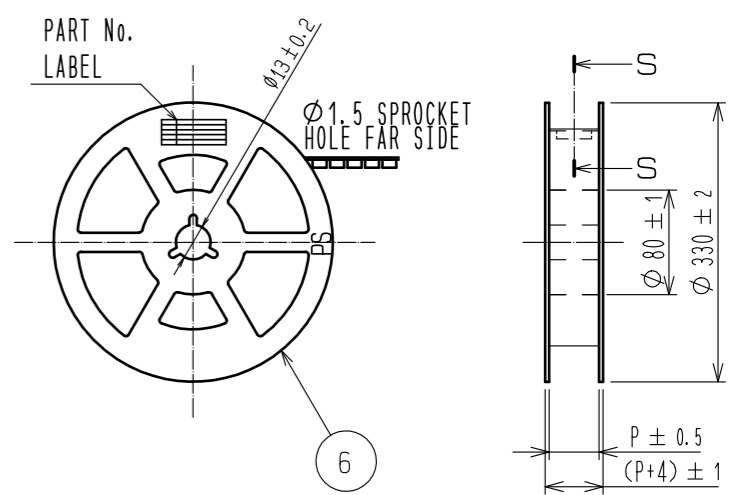
SUPPLIER  
QUANTITY  
PART No.  
CODE No.  
DATE OF MANUFACTURED

DETAIL OF PART No. LABEL

生産月日	年 月 日
図番	CL537-****-*-86
品名	DF12(5.0)-*DP-0.5V(86)
納入数量	1000K $\phi$
納入者	ヒロセ電機(株)

- NOTES 4 : 1 REEL 1000 CONNECTORS.  
 5 : AT THE BEGINNING OF THE REEL, 30 COMPONENTS SHALL BE EMPTY.  
 AT THE END OF THE REEL, 20 COMPONENTS SHALL BE EMPTY.  
 6 WHEN THE TAPE WIDTH IS 32 mm, SPROCKET HOLES SHALL BE SET ON BOTH SIDES OF REEL AS SHOWN ON THIS DRAWING.  
 7 : PEEL FORCE REFERS TO JIS C 0806.  
 8 : THE REEL IS PACKED WITH A POLYETHYLENE MATERIAL, TOGETHER WITH A DRYING AGENT.  
 9 AFTER PACKING, ROLL 2 METERS OF THE REINFORCEMENT COLLAR TO OUTER CIRCUMFERENCE OF TAPE AND REEL POCKET, AND TAPE DOWN AT THE END THE COLLAR.

CODE No.	CONTACT	J	K	L	M	N	P
CL537-0153-9-86	20	16	-	7.5	12	0.38	17.5
CL537-0155-4-86	30	24	-	11.5	12	0.38	25.5
CL537-0156-7-86	36	24	-	11.5	12	0.38	25.5
CL537-0157-0-86	40	24	-	11.5	12	0.38	25.5
CL537-0159-5-86	50	24	-	11.5	8	0.30	25.5
CL537-0161-7-86	60	32	28.4	14.2	12	0.38	33.5

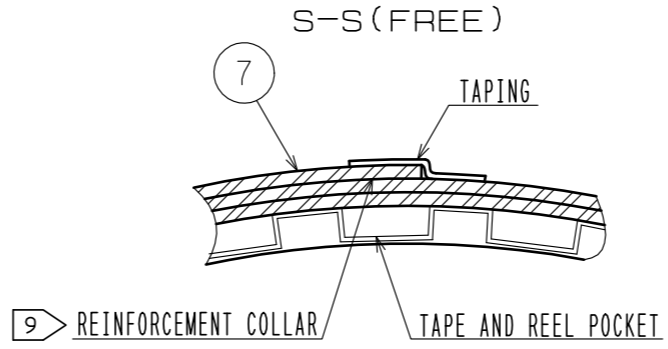

<b>HRS</b>	DRAWING NO.	EDC3-163514-77
	PART NO.	DF12(5.0)-*DP-0.5V(86)
	CODE NO.	CL537
		$\triangle$ 2/2