

LOC	DIST	P	F	ZONE	LTR	DESCRIPTION	DATE	APPD
BD	77					REV PER ECN BD3132	09/11/89	-
						OBS -6 PER EC 0020-831-93	03/15/94	SB
						SUPSD -1 PER EC 0020-571-96	17 MAR 97	RT
						REV PER EC 0640-429-98	18 FEB 99	RT

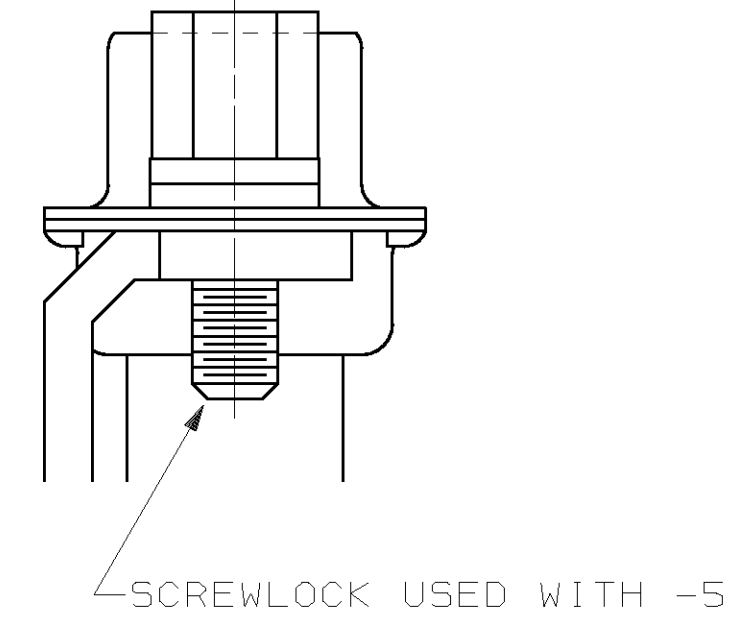

1. CONNECTOR MATES WITH ANY 9 POS. RECEPTACLE IN AMPLIMITE SERIES & COMPLIES WITH AMP SPEC. 108-40,005 WHERE APPLICABLE.
2. FLAME RETARDANT 94V-0 RATED THERMOPLASTIC; COLOR: BLACK.
3. STEEL PER ASTM A109.
4. BRASS PER MIL-C-50.
5. SCREWLOCKS: STEEL PER ASTM A109, WASHERS: STEEL PER ASTM A108.
6. TIN PLATING PER MIL-T-10727, ZINC PLATING PER ASTM B633; TYPE III; CLASS SC1; CLEAR CHROMATE, GOLD PLATING PER MIL-G-45204, NICKEL PLATING PER QQ-N-290.
7. TIN PLATED.
8. ZINC PLATED.
9. GOLD FLASH FOR A LENGTH OF .150 MIN FROM MATING END, .000100 MIN TIN-LEAD ON OPPOSITE END, BOTH OVER .000050 MIN NICKEL.
10. GOLD PLATED FOR LENGTH OF .150 MIN FROM MATING END, .000030 MIN GOLD IN MATED AREA, .000100 MIN TIN-LEAD ON OPPOSITE END, BOTH OVER .000050 MIN NICKEL.
11. ADVANCED PART NUMBER, NOT PRODUCTION TOOLED.
12. PLAIN WASHERS ARE FOR -1 THRU -5.

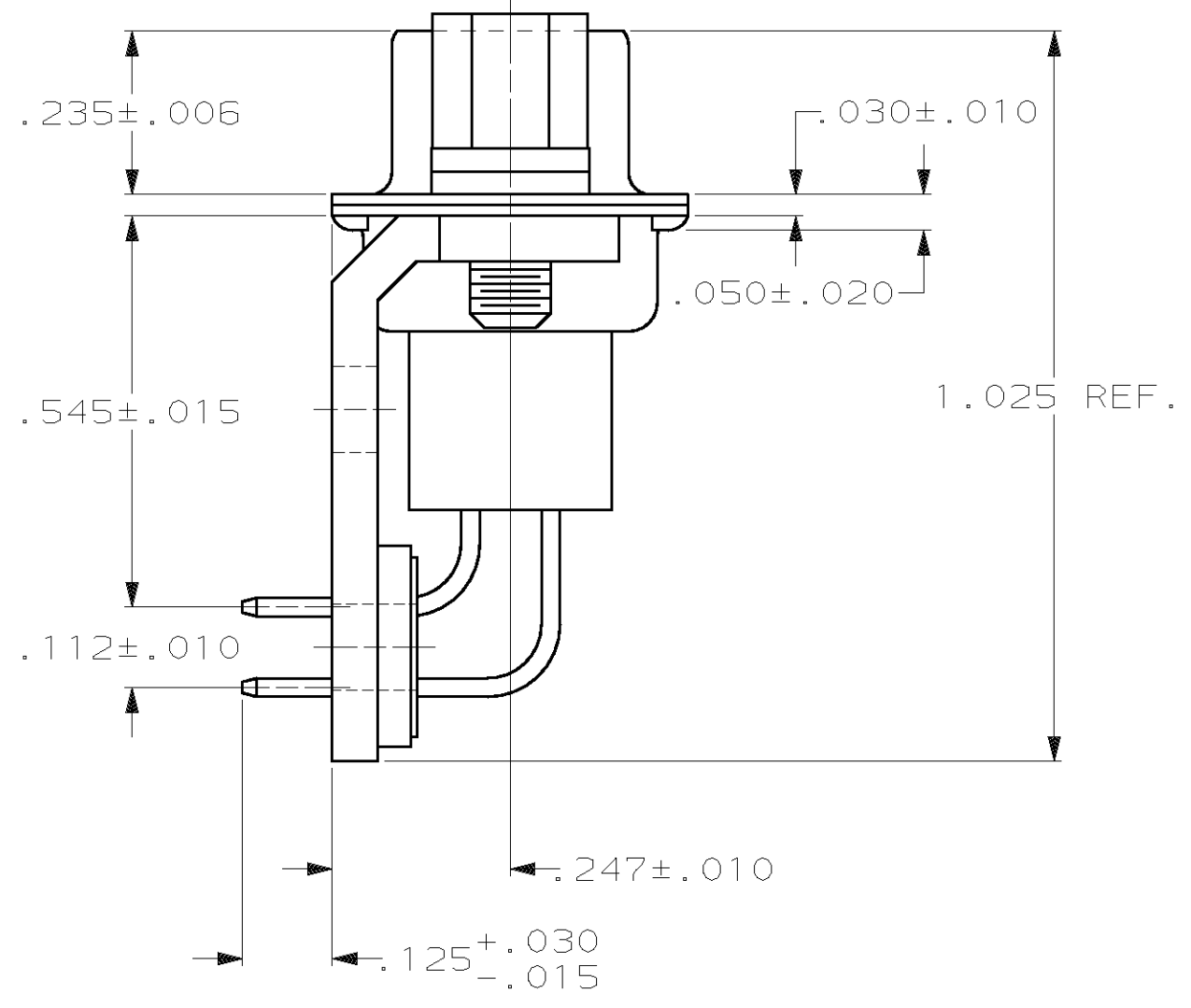
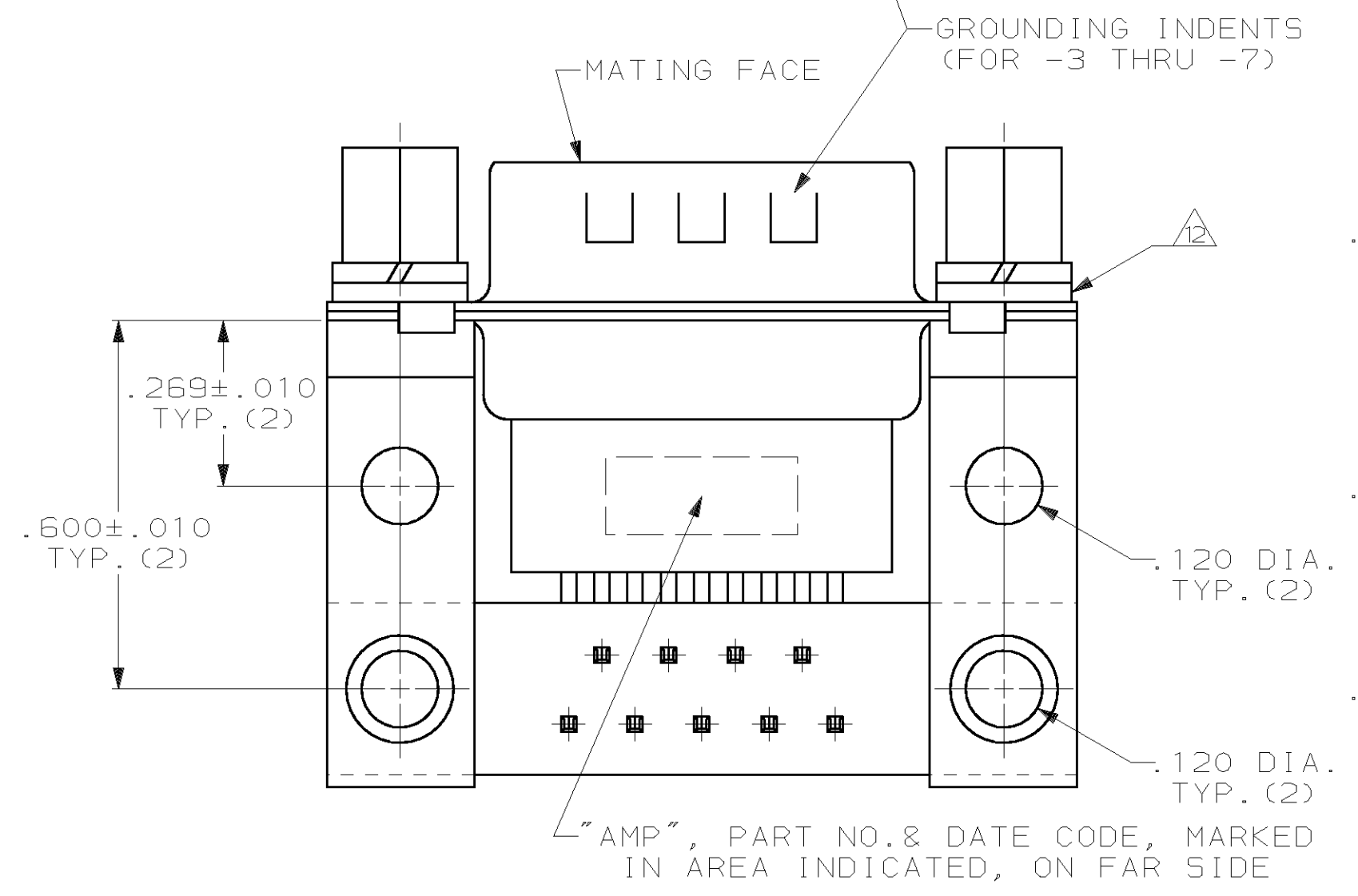
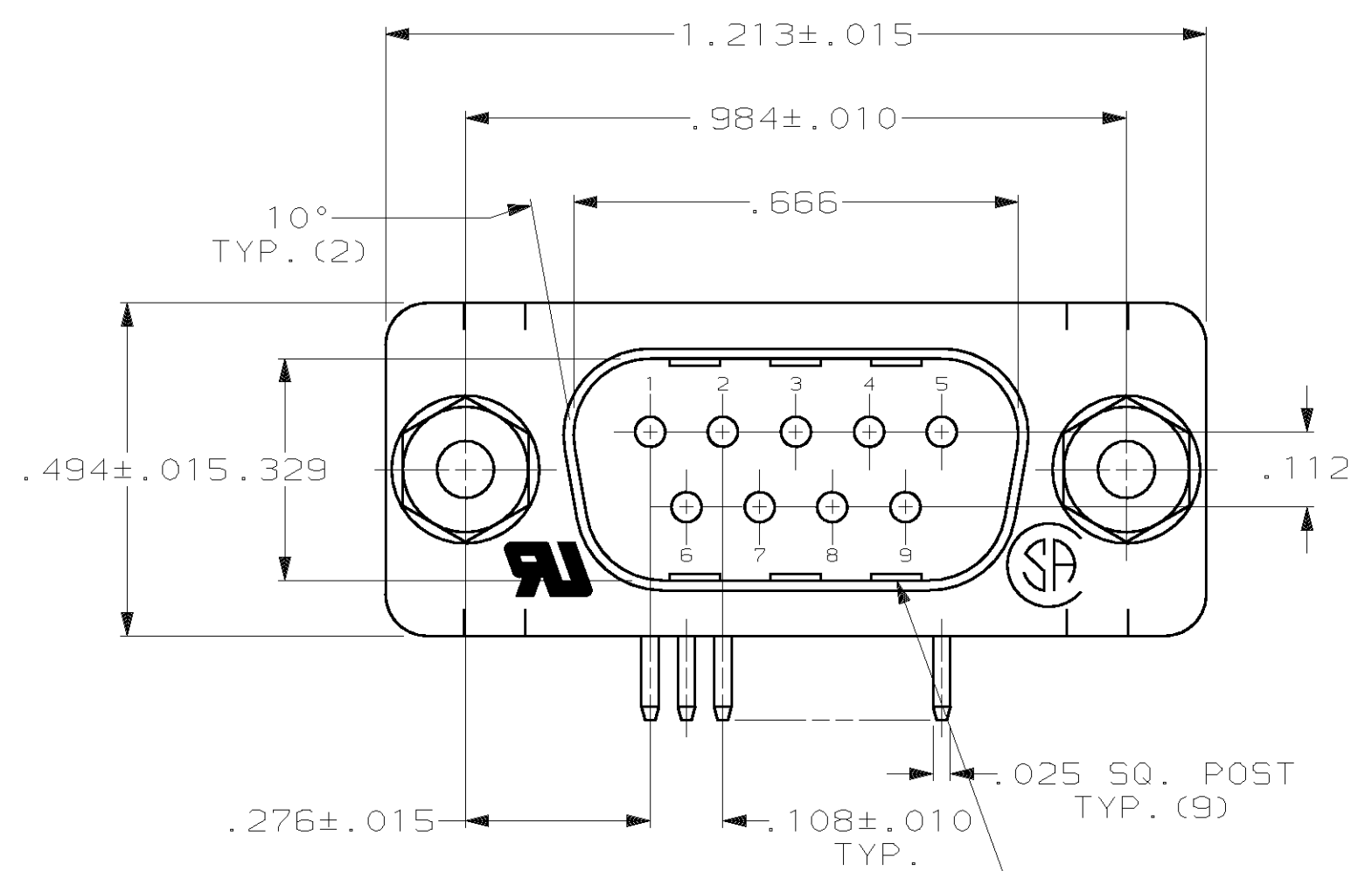
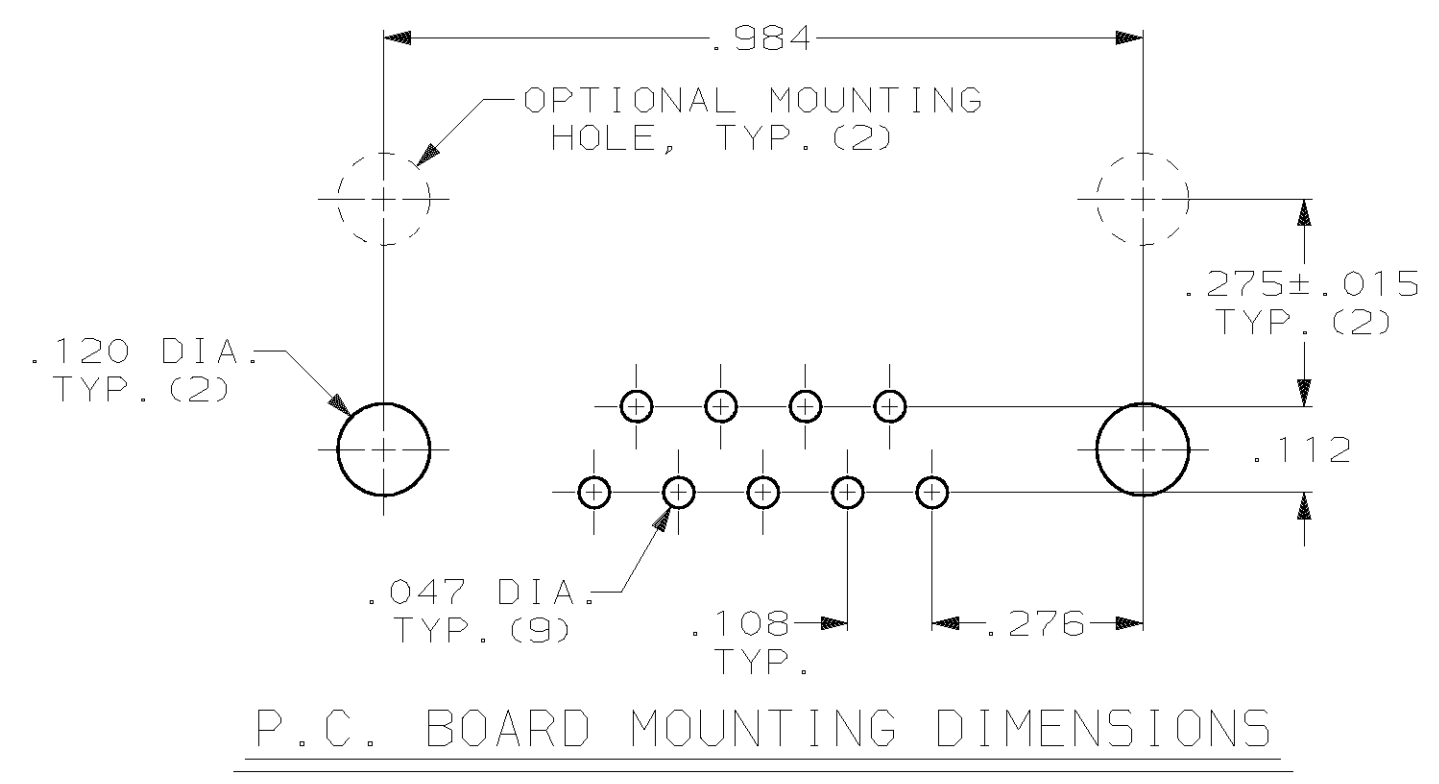

OBSOLETE	9	747197-7
OBSOLETE	10	747197-6
	10	747197-5
	10	747197-4
SUPSD BY	9	747197-3
OBSOLETE	10	747197-2
OBSOLETE	9	747197-1

DO NOT SCALE PRINT. UNLESS SPECIFIED DIMENSIONS IN INCHES TOLERANCES ON:		DR 08-26-85 S.WELDON		AMP AMP Incorporated Harrisburg, PA 17105-3508	
2 PLC DEC ±		CHK 08-27-85 J.GERACE			
3 PLC DEC ± .005		APPD 08-27-85 C.MACKRIDES		NAME	
ANGLES ± 2°		APPD 08-27-85 J.ASSINI		PLUG ASSEMBLY, SIZE 1, 9 POSN, RIGHT ANGLE, .545 SERIES, .025 SQ. POSTS, W/ SCREWLOCKS, AMPLIMITE™ HDP	
MATERIAL		PRODUCT SPEC		SIZE	
MOLDED PARTS: 2		-		D	
SHELLS & BRACKETS: 2		-		CAGE CODE	
CONTACTS: 2		-		00779	
HARDWARE: 2		-		DRAWING NO	
FINISH: 2		-		C-747197	
SHELLS & BRACKETS: 2		-		SCALE	
CONTACTS: SEE TABLE		-		-	
HARDWARE: 2		-		SHEET	
		-		1 OF 1	

THIS DRAWING IS A CONTROLLED DOCUMENT FOR AMP INCORPORATED. IT IS SUBJECT TO CHANGE AND THE CONTROLLING ENGINEERING ORGANIZATION SHOULD BE CONTACTED FOR THE LATEST REVISION.