

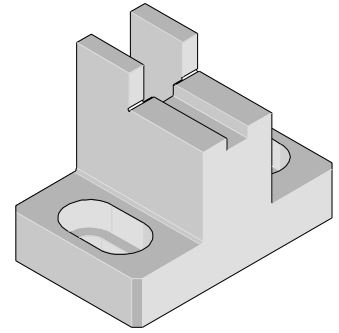

**I-Trac™ Right Angle Power Module  
Application Tooling Specification  
Support Tool  
Order No. 62201-8636**



**FEATURES**

- Tool supplied with clearance slot for power module connector terminal tips
- Tool provides uniform support to PCB when power module is pressed in
- Can be placed under the PCB
- Used as a stand-alone tool when power module is installed separately

**SCOPE**

This tool is used only when installing I-Trac™ Right Angle Power Modules with no Daughtercard assemblies on either side, to provide PCB support.

Products: I-Trac™ Right Angle Power Module Assembly 78226 and 78228 Series, 7 Row Assemblies. See Product List below for specific part numbers.

**Product List**

The following is a partial list of the product order numbers and their specifications this tool is designed to run. Updates to this list are available on [www.molex.com](http://www.molex.com).

Right Angle Power Module Series Number	Row	Assembly Order Number				
78226	7	78226-1001	78226-1002	78226-1003	78226-1004	78226-1005
		78226-1101	78226-1102	78226-1103	78226-1104	78226-1105
		78226-1201	78226-1202	78226-1203	78226-1204	78226-1205
		78226-5001	78226-5002	78226-5003	78226-5004	78226-5005
78228	7	78228-1001	78228-1002	78228-1003		
		78228-5001	78228-5002	78228-5003		
<b>This tool is used only when installing Right Angle Power Modules with no Daughtercard assemblies on either side, to provide PCB support.</b>						

**Tool Setup**

The I-Trac™ Right Angle Power Module Support Tool is placed directly under the PCB board. This is done by placing the support tool under the power module or by moving the PCB over the support tool. The method used will depend on the customer's application. See Figure 1.

Be certain to orient the support tool properly under the PCB. The slot of the support tool must be directly below the connector terminals that push through the PCB when the Power Module is assembled to the board. See Figure 2.

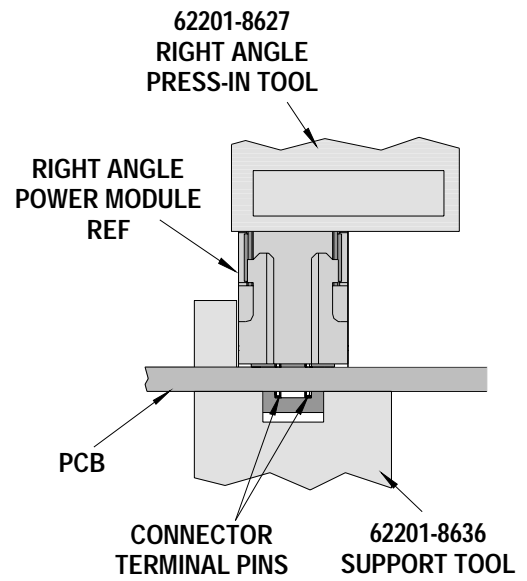
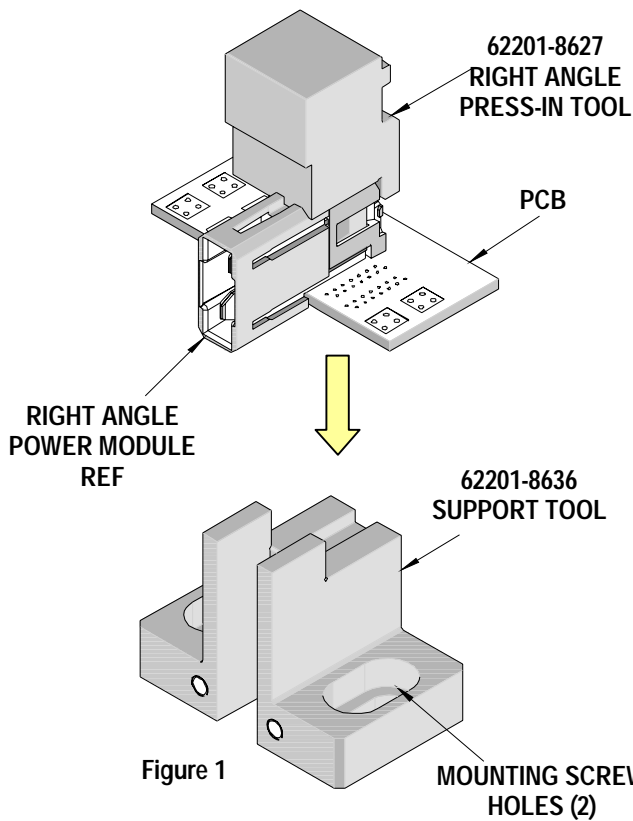

Figure 2  
(From Back View)

## Tool Installation

The Support Tool can be a stand-alone tool shown in Figure 3 or placed in a fixed position shown in Figure 2.

The Support Tool may be held in place with 4mm socket head cap screws (not included).

Reference: The 62201-8636- Support Tool is 29.0mm (1.14 in.) high and 24mm (0.94 in.) long.

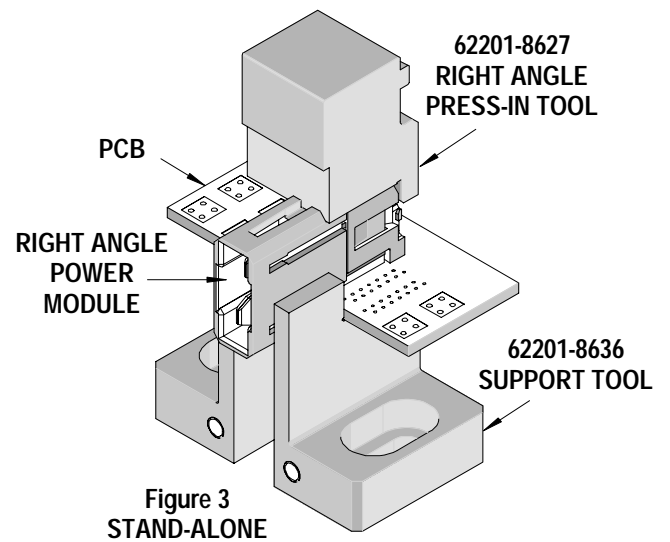

## Press Equipment Recommendations

Many types of presses can be used to install I-Trac™ connectors, but to assure consistent connector installation Molex recommends the following press criteria:

1. The capability to detect force variations as low as 4.5kg (10 lb) during the press-in cycle; excessive force measurements should stop the press-in cycle.
2. The rate of pressing can be regulated as low as 0.13mm (0.005 in) per second.
3. Press stroke control to within 0.25mm (0.010 in).
4. Total press stroke must be at least 19mm (0.75 in).
5. For statistical purposes, automatic collection of force and distance data.

**CAUTION:** To prevent injury, never operate any press without the guards in place. Refer to the press manufacturer's instruction manual.

**CAUTION:** Molex application tooling specifications are valid only when used with Molex connectors and tooling.

## Contact Information

For more information on Molex application tooling please contact Molex at 1-800-786-6539.

**Americas Headquarters**  
Lisle, Illinois 60532 U.S.A.  
1-800-78MOLEX  
amerinfo@molex.com

**Far East North Headquarters**  
Yamato, Kanagawa, Japan  
81-462-65-2324  
feninfo@molex.com

**Far East South Headquarters**  
Jurong, Singapore  
65-6-268-6868  
fesinfo@molex.com

**European Headquarters**  
Munich, Germany  
49-89-413092-0  
eurinfo@molex.com

**Corporate Headquarters**  
2222 Wellington Ct.  
Lisle, IL 60532 U.S.A.  
630-969-4550  
Fax: 630-969-1352

Visit our Web site at <http://www.molex.com>