

THIS IS ISSUED IN STRICT CONFIDENCE ON CONDITION THAT IT IS NOT USED AS A BASIS FOR MANUFACTURE OR SALE, AND THAT IT IS NOT COPIED, REPRINTED OR DISCLOSED TO A THIRD PARTY EITHER WHOLLY OR IN PART WITHOUT THE PRIOR WRITTEN CONSENT OF ITT CANNON ELECTRIC.

REVISIONS				
ZONE	LTR	DESCRIPTION	DATE	APPROVED
	G	REDRAWN TO LATEST STANDARDS DCIN 115270	9/1/81	P.O.B

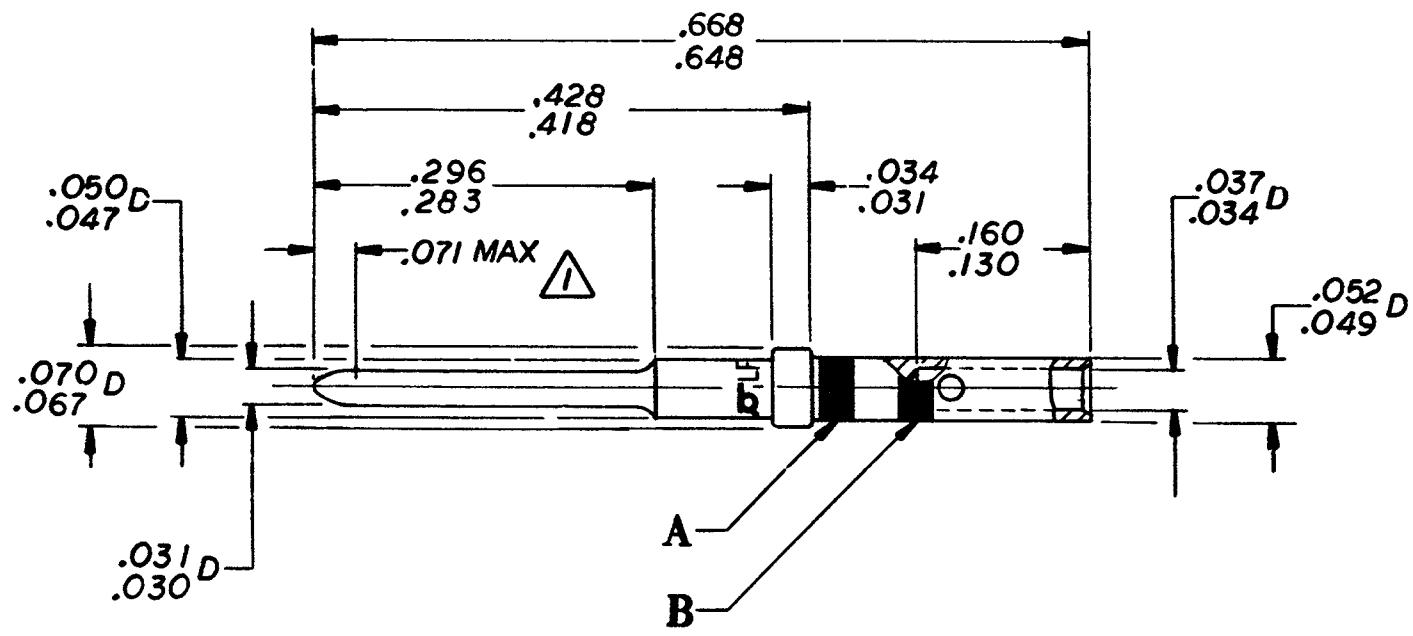

WIRE ACCOM	CRIMP TOOL PART NUMBER	LOCATOR PART NUMBER	INSERT/EXT. TOOL PART NUMBER
22,24,26	M22520/2-01	M22520/2-23	CIT-DPXMA-22-1 CET-DPXMA-22 CIET-22

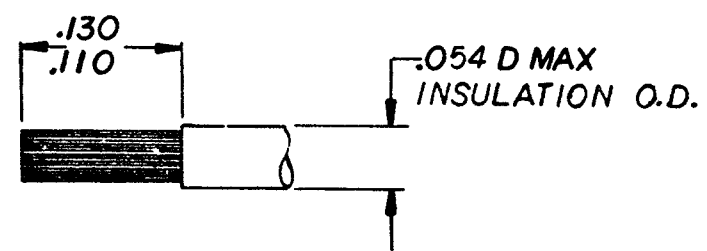

WIRE STRIP DIMENSION

COLOR BAND IDENTIFICATION

BAND A ORANGE
BAND B GREEN

NOTES: UNLESS OTHERWISE SPECIFIED.
△ ELECTRICAL ENGAGEMENT POINT.

REFERENCE ARINC 600		INTENDED USE CUSTOMER USE		PART NUMBER 030-2259-000					
DIMENSIONS IN INCHES, TOLERANCES FOR DECIMALS AND ANGLES AS SHOWN DO NOT SCALE		PRODUCT SAFETY REVIEWED BY <i>Paul P. Curran</i> 17 Sept 81							
MATERIAL COPPER ALLOY		REFERENCE DOCUMENT							
FINISH GOLD OVER NICKEL		REVIEWED-MATERIALS & PROCESS		CONTACT, PIN BKAD/DPXMA SIZE 2222 LOW INSERTION FORCE					
TREATMENT		APPROVED <i>[Signature]</i> 10/1/81		<table border="1"> <tr> <td>SIZE</td> <td>CODE IDENT NO.</td> </tr> <tr> <td>C</td> <td>71468</td> </tr> </table>		SIZE	CODE IDENT NO.	C	71468
SIZE	CODE IDENT NO.								
C	71468								
		APPROVED		<table border="1"> <tr> <td>SCALE</td> <td>NONE</td> <td>WT.</td> <td></td> </tr> </table>		SCALE	NONE	WT.	
SCALE	NONE	WT.							
				SHEET 1 OF 1					

030-2259-000