

DRAWING MADE IN THIRD ANGLE PROJECTION

© COPYRIGHT 1977 BY AMP INCORPORATED, HARRISBURG, PA.
ALL INTERNATIONAL RIGHTS RESERVED. AMP INCORPORATED PRODUCTS
COVERED BY U. S. AND FOREIGN PATENTS AND/OR PATENTS PENDING.

UNPUBLISHED COPY NOT TO BE
REPRODUCED NOR PUBLISHED
WITHOUT WRITTEN PERMISSION
OF AMP INCORPORATED.

REVISIONS					LOC	L.
P	F	ZONE	LTR	DESCRIPTION	DATE	APPROVED
	F			ECO-08-020831	PY	10-08 BW

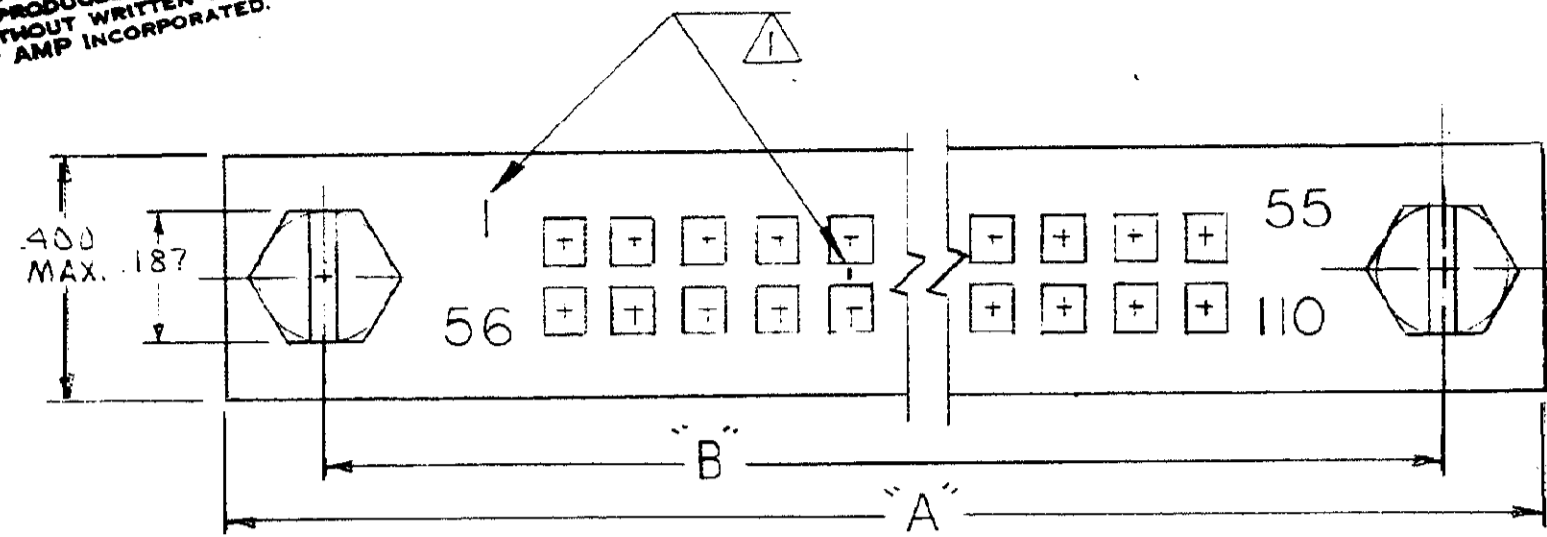

REPLACEMENT JACKSCREW KIT

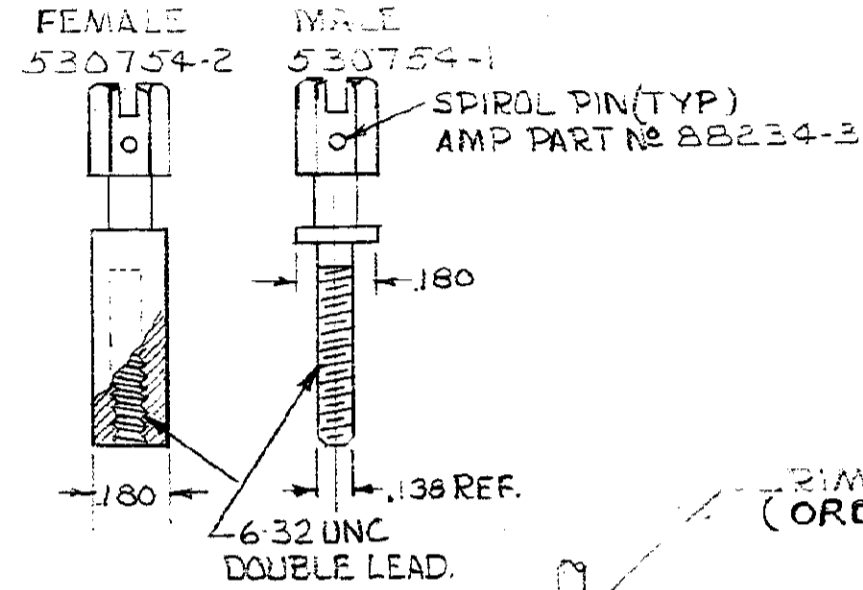

CRIMP-SNAP CONTACT P/N 530750#22#26 AWG.
(ORDERED SEPARATELY)

HOUSING MATL: GLASS FILLED POLYESTER
COLOR-BLUE

AMP, 00779, PART NO. DATE
CODE AND MILITARY PART NO
MARKED IN THIS AREA (SIDE OPTIONAL)

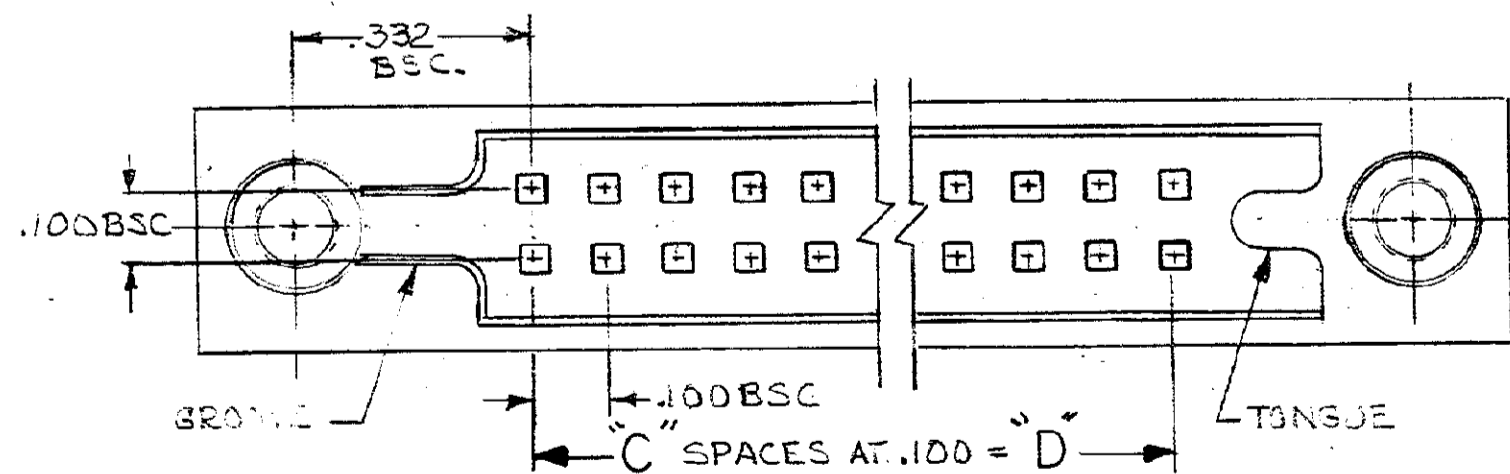
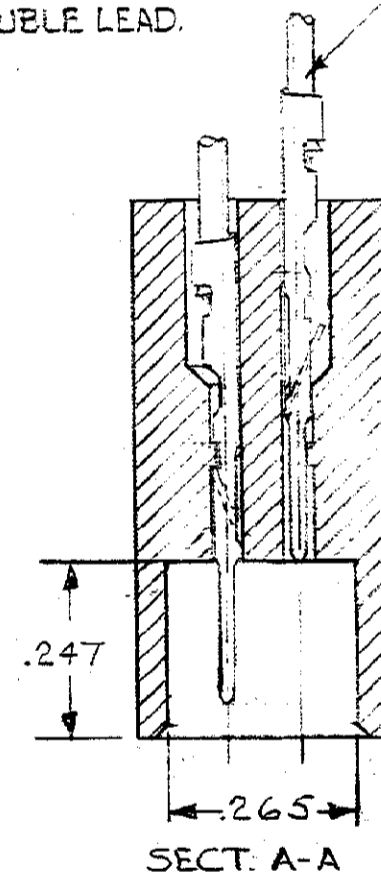
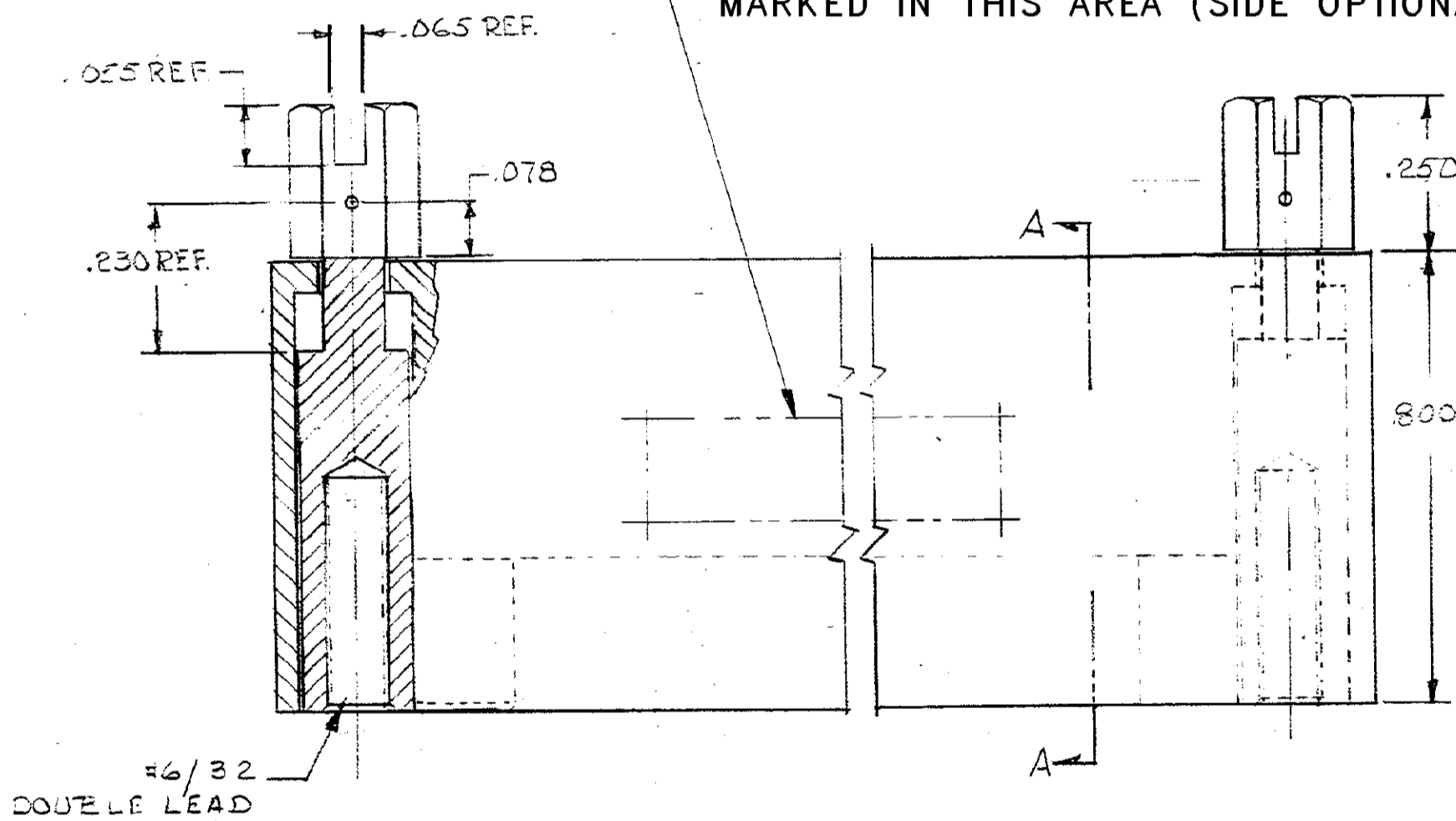

- 1. NUMBERS (SEE TABLE SHEET 2) AND LINES INDICATING EVERY 5 CAVITIES MARKED WHERE SHOWN
 - 2. MEETS PERFORMANCE REQUIREMENTS MIL-C 55302
 - 3. MATES WITH EXTERNAL KEY TYPE RECEPTACLE ASSY. 1000 SERIES, WHICH USES MOUNTING HARDWARE P/N 532484 (2 REQ'D) TO ENGAGE JACKSCREWS.
4. OBS PART NO.

UNLESS OTHERWISE SPECIFIED DIMENSIONS ARE IN INCHES. TOLERANCES ON: DECIMALS ±.010 ANGLES ±		CONTRACT NO	PART NO	
MATERIAL	SEE CALL-OUT	DR <i>W. Williams</i> 4-15-76	AMP INCORPORATED Harrisburg, Pa.	
FINISH	SEE CALL-OUT	CHK <i>W. Williams</i> 4-2-76	NAME PIN HEADER HOUSING ASSEMBLY, CRIMP-SNAP BOX PIN CONTACTS.	
		APPD <i>R. Williams</i> 4-2-76	SIZE	REV
		APPD <i>R. Williams</i> 4-21-76	C	F
		DSGN APPD	CODE	IDENT NO
		OTHER APPD	00779	530752
			DRAWING NO	
			530752	
		SCALE 4-1	SHEET 1 OF 2	

DRAWING MADE IN THIRD ANGLE PROJECTION

© COPYRIGHT 1977 BY AMP INCORPORATED, HARRISBURG, PA. ALL INTERNATIONAL RIGHTS RESERVED. AMP INCORPORATED PRODUCTS COVERED BY U. S. AND FOREIGN PATENTS AND/OR PATENTS PENDING.

UNPUBLISHED COPY NOT REPRODUCED NOR PUBLISHED WITHOUT WRITTEN PERMISSION OF AMP INCORPORATED.

LCC		DIST	
DF	FO		
REVISIONS			
NO.	ZONE/LTR	DESCRIPTION	DATE APPROVED
		SEE SHEET 1	

M55302/113-87		M	M	1/56	55/110	5.400	54	6.065	6.355	3-530752-6		
-86	↑	M	F	↑	↓	↑	↓	↑	↓	3-	-5	
-85		F	M	↓	↑	↓	↑	↓	↑	5-	-4	
-84		F	F	1/56	55/110	5.400	54	6.065	6.355	3-	-3	
-79		M	M	1/51	50/100	4.900	49	5.565	5.855	3-	-2	
-78		M	F	↓	↑	↓	↑	↓	↑	3-	-1	
-77		F	M	↓	↑	↓	↑	↓	↑	3-	-0	
-76		F	F	1/51	50/100	4.900	49	5.565	5.855	2-	-9	
-71		M	M	1/46	45/90	4.400	44	5.065	5.355	2-	-8	
-70		M	F	↓	↑	↓	↑	↓	↑	2-	-7	
-69		F	M	↓	↑	↓	↑	↓	↑	2-	-6	
-68		F	F	1/46	45/90	4.400	44	5.065	5.355	2-	-5	
-63		M	M	1/41	40/80	3.900	39	4.565	4.855	2-	-4	
-62		M	F	↓	↑	↓	↑	↓	↑	2-	-3	
-61		F	M	↓	↑	↓	↑	↓	↑	2-	-2	
-60		F	F	1/41	40/80	3.900	39	4.565	4.855	2-	-1	
-55		M	M	1/31	30/60	2.900	29	3.565	3.855	2-	-0	
-54		M	F	↓	↑	↓	↑	↓	↑	1-	-9	
-53		F	M	↓	↑	↓	↑	↓	↑	1-	-8	
-52		F	F	1/31	30/60	2.900	29	3.565	3.855	1-	-7	
-47		M	M	1/26	25/50	2.400	24	3.065	3.355	1-	-6	
-46		M	F	↓	↑	↓	↑	↓	↑	1-	-5	
-45		F	M	↓	↑	↓	↑	↓	↑	1-	-4	
-44		F	F	1/26	25/50	2.400	24	3.065	3.355	1-	-3	
-39		M	M	1/21	20/40	1.900	19	2.565	2.855	1-	-2	
-38		M	F	↓	↑	↓	↑	↓	↑	1-	-1	
-37		F	M	↓	↑	↓	↑	↓	↑	1-	-0	
-36		F	F	1/21	20/40	1.900	19	2.565	2.855		-9	
-31		M	M	1/16	15/30	1.400	14	2.065	2.355		-8	
-30		M	F	↓	↑	↓	↑	↓	↑		-7	
-29		F	M	↓	↑	↓	↑	↓	↑		-6	
-28		F	F	1/16	15/30	1.400	14	2.065	2.355		-5	
-10		M	M	1/36	35/70	3.400	34	4.065	4.355		-4	
-09		M	F	↓	↑	↓	↑	↓	↑		-3	
-08		F	M	↓	↑	↓	↑	↓	↑		-2	
-08		F	F	1/36	35/70	3.400	34	4.065	4.355	530752-1		
M55302/113-07		GROOVE KEYING		TONGUE		CAVITY IDENT.		D	C	B	A	ASSEMBLY PART NO.

UNLESS OTHERWISE SPECIFIED DIMENSIONS ARE IN INCHES.
TOLERANCES ON:
DECIMALS ±
ANGLES ±

MATERIAL

FINISH

CONTRACT NO
7-11-77

DR. *M. Smith*
CHK

APPD. *K. Williams* 7-12-77

APPD. *K. Shawman* 7-13-77

DSGN APPD

OTHER APPD

NAME
PIN HEADER HOUSING ASSY.
FOR CRIMP-SNAP BOX PIN CONTACTS.

SIZE CODE IDENT NO DRAWING NO
C 00779 530752

SCALE SHEET 2 OF 2

REV F



CUSTOMER DRAWING