

SECTION A-A  
SCALE 4:1

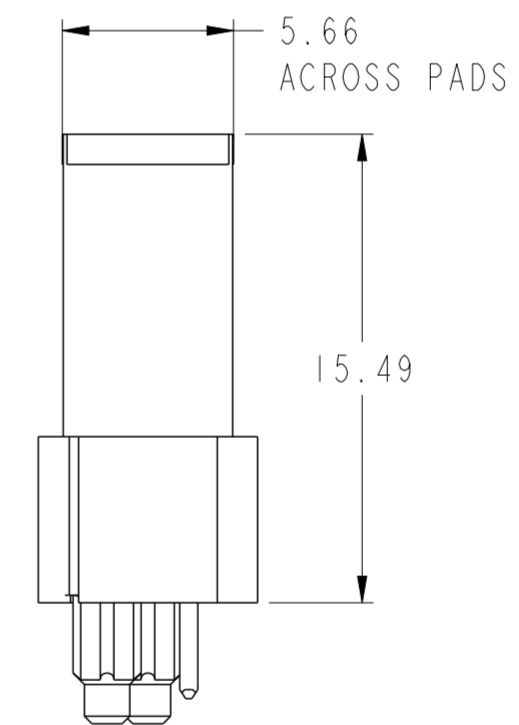
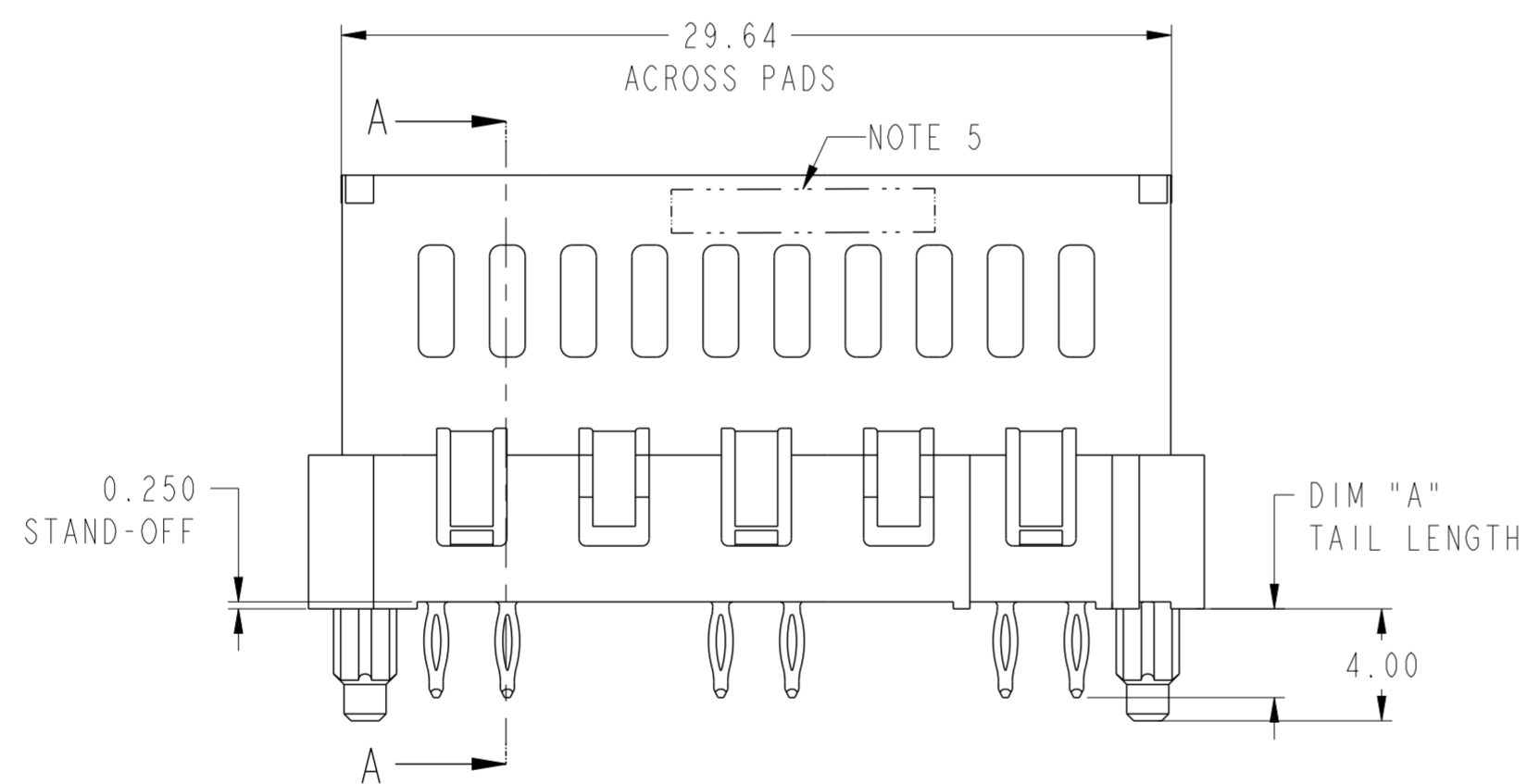

spec ref	-	dr	Julia Wang	2013/01/24	projection	MM	size	A2	scale	1:1	
tolerance std	ISO 406 ISO 1101	eng	Sunny2 Liu	2016/05/05			ecn no	ELX-DG-24036-1	rel level	Released	
TOLERANCES UNLESS OTHERWISE SPECIFIED		chr	Terris Liu	2016/05/20							product family
surface	ASME Y14.5	appr	Pei-Ming Zheng	2016/05/24	linear	0.X	±0.5	Amphenol FCI	cat. no.	Product - Customer Drw	sheet 1 of 4
					angular	0°	±2°				

PDS: Rev :B

STATUS:Released

Printed: May 24, 2016

Amphenol  
FCi

© 2016 AFci

CONTACT TYPE	TOP LAYER DESCRIPTION	TABLE 1 (HPCE / SOLDER TAILS) PLATED THROUGH-HOLE REQUIREMENTS				
		DRILLED HOLE DIAMETER	COPPER THICKNESS	TIN-LEAD THICKNESS	TIN THICKNESS	FINISHED HOLE DIAMETER
POWER & SIGNAL	TIN-LEAD	1.10-1.16 (1.15 DRILL)	0.025 - 0.050	0.005 - 0.015	--	0.94 - 1.10
	IMMERSION TIN	1.10-1.16 (1.15 DRILL)	0.025 - 0.050	--	0.9 - 1.5um	0.94 - 1.10
	COPPER (SEE NOTE 8)	1.10-1.16 (1.15 DRILL)	0.025 - 0.050	--	--	0.94 - 1.10

CONTACT TYPE	TOP LAYER DESCRIPTION	TABLE 2 (HPCE / PRESS-FIT TAILS) PLATED THROUGH-HOLE REQUIREMENTS				
		DRILLED HOLE DIAMETER	COPPER THICKNESS	TIN-LEAD THICKNESS	TIN THICKNESS	FINISHED HOLE DIAMETER
POWER & SIGNAL	TIN-LEAD	0.81-0.86 (0.85 DRILL)	0.025 - 0.050	0.005 - 0.015	--	0.65 - 0.80
	IMMERSION TIN	0.81-0.86 (0.85 DRILL)	0.025 - 0.050	--	0.9 - 1.5um	0.70 - 0.80
	COPPER (SEE NOTE 8)	0.81-0.86 (0.85 DRILL)	0.025 - 0.050	--	--	0.70 - 0.80

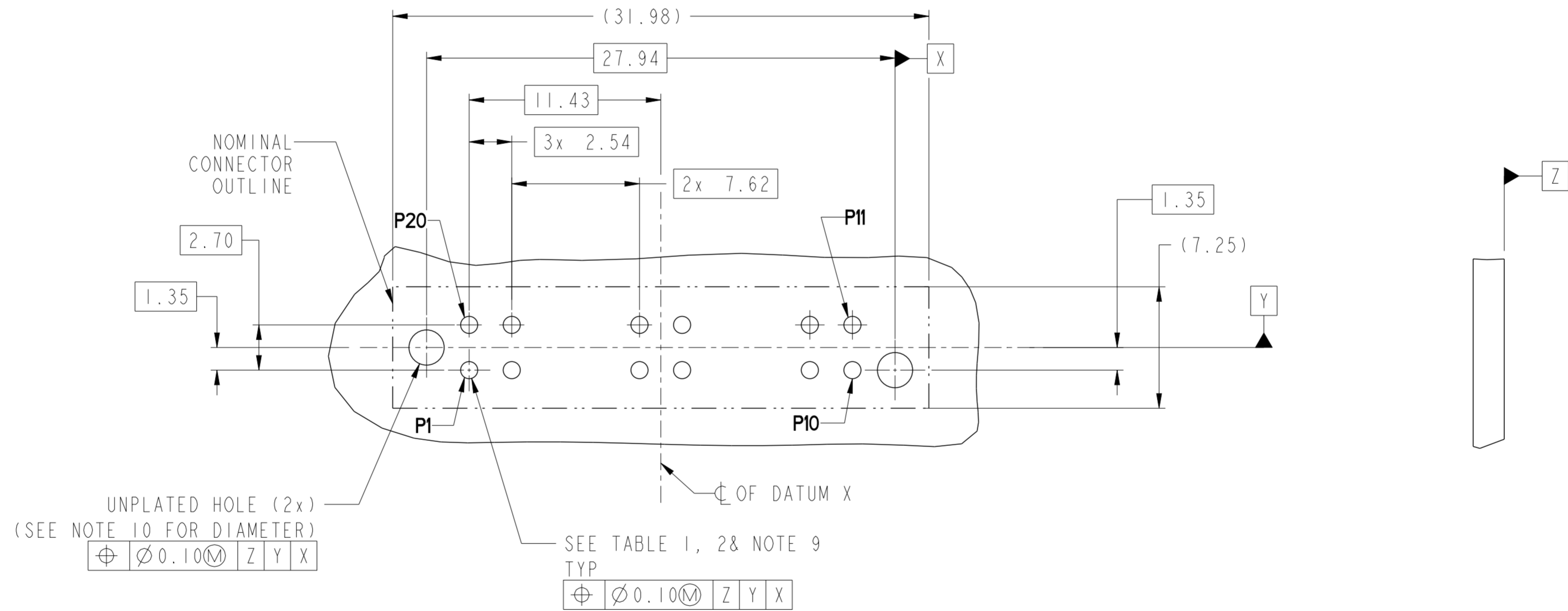

spec ref	-	dr	Julia Wang	2013/01/24	projection	MM	size	A2	scale	1:1
tolerance std	ISO 406 ISO 1101	eng	Sunny2 Liu	2016/05/05			ecn no	ELX-DG-24036-1	rel level	Released
TOLERANCES UNLESS OTHERWISE SPECIFIED		chr	Terris Liu	2016/05/20						
		appr	Pai-Ming Zheng	2016/05/24						
surface	ASME Y14.5	linear	0.X	$\pm 0.5$	<b>Amphenol FCI</b>		product family	STD VERT RECPT 20P OMIT 8P	cat. no.	10124179
		angular	0°	$\pm 2^\circ$	<b>Amphenol FCI</b>		product family	HIGH POWER CARD EDGE	Product - Customer Drw	sheet 2 of 4

PDS: Rev :B

STATUS:Released

Printed: May 24, 2016

Amphenol FCI

© 2016 APCI

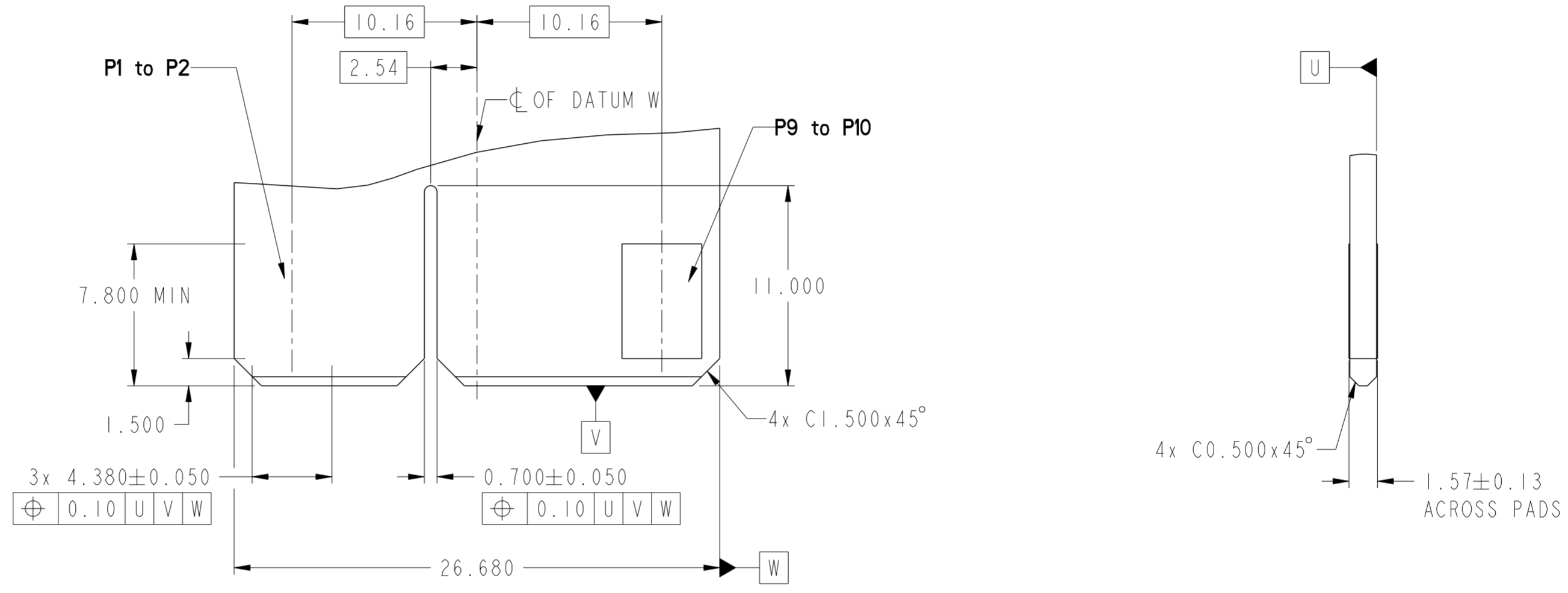

Amphenol  
FCi

© 2016 AFci

spec ref	-	dr	Julia Wang	2013/01/24	projection	MM	size	A2	scale	1:1	
tolerance std	ISO 406 ISO 1101	eng	Sunny2 Liu	2016/05/05			ecn no	ELX-DG-24036-1			
TOLERANCES UNLESS OTHERWISE SPECIFIED		chr	Terris Liu	2016/05/20			rel level	Released			
surface	ASME Y14.5	appr	Pei-Ming Zheng	2016/05/24			product family				
linear	0.X ±0.5 0.XX ±0.25 0.XXX ±0.10	Amphenol FCi		title	STD VERT RECPT 20P OMIT 8P HIGH POWER CARD EDGE			divg no	10124179		
angular	0° ±2°			cat. no.	Product - Customer Drw			sheet	3 of 4		

PDS: Rev :B

STATUS:Released

Printed: May 24, 2016

HPCE PART NUMBER (TABLE 3)

PART NUMBER	TAIL TYPE	ORIENTATION KEY	DIM "A" TYPICAL TAIL LENGTH	DIM "B" RECOMMENDED BOARD THICKNESS
10124179-001LF	SOLDER	YES	3.17 ±0.25	1.59 - 2.38
10124179-002LF	SOLDER	NO		
10124179-003LF	PRESS-FIT	YES	3.17 ±0.25	1.57 MIN
10124179-004LF	PRESS-FIT	NO		

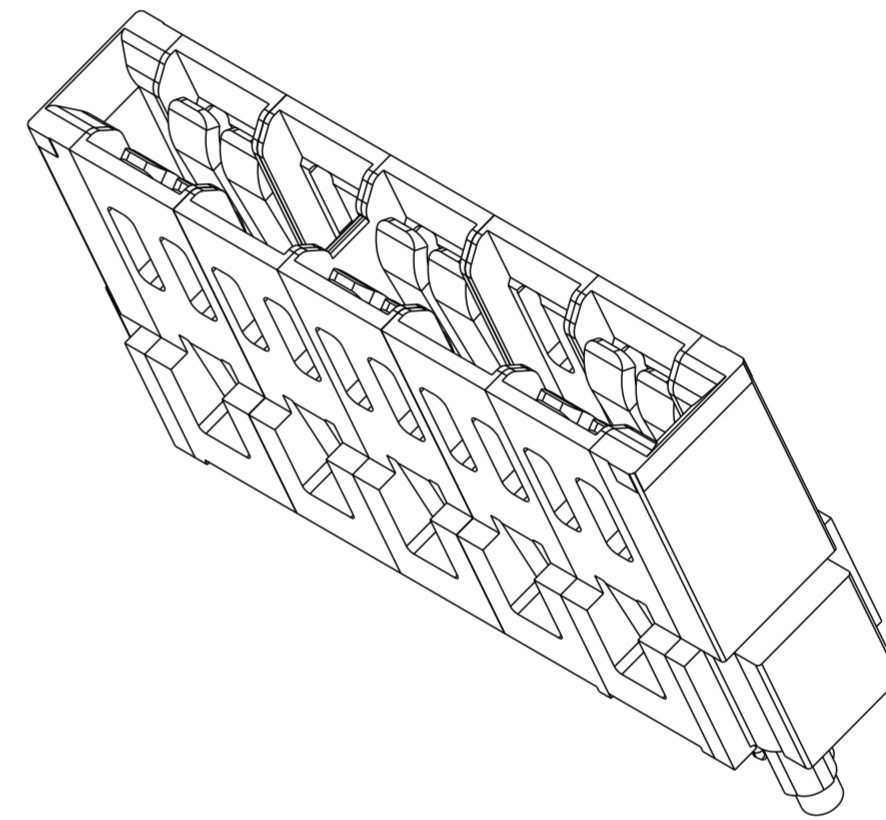

NOTES:

1. CONNECTOR MATERIALS:  
 HOUSING: HIGH TEMPERATURE THERMAL PLASTIC, BLACK  
 UL 94V-0 COMPLIANT  
 CONTACTS: HIGH PERFORMANCE COPPER ALLOY.
2. CONTACT FINISH REF. GS-12-604 SECTION 5.2.
3. PRODUCT SPECIFICATION: GS-12-604.
4. APPLICATION SPECIFICATION: GS-20-128.
5. PRODUCT MARKING ON HOUSING IN AREA SHOWN MEETS AFCI SPECIFICATION: GS-24-007.
6. PACKAGING MEETS FCI SPECIFICATION GS-14-937.
7. HOUSING COMPONENT WILL WITHSTAND EXPOSURE TO 260°C PEAK TEMPERATURE FOR 60 SECONDS IN A CONVECTION, INFRA-RED, OR VAPOR PHASE REFLOW OVEN.
8. COPPER PLATING THICKNESS IN CENTER OF VIA-HOLE CAN BE NO MORE THAN 0.003 LESS THAN OTHER AREAS.
9. ALL HOLE SIZES ARE FINISHED HOLE SIZES.
10. MOUNTING HOLES ARE UNPLATED  
 Ø 2.40 +/- 0.1 FOR PRESS-FIT TAILS  
 Ø 2.18 +/- 0.03 FOR SOLDER TAILS
11. PRESS FIT APPLICATION TOOL DRAWING : 10119453.
12. A SYMBOL WILL BE NEXT TO ANY DIMENSION, VIEW, OR NOTE WHICH HAS BEEN MODIFIED WITH THE CURRENT DRAWING REVISION.

spec ref	-	dr	Julia Wang	2013/01/24	projection	MM	size	A2	scale	1:1	
tolerance std	ISO 406 ISO 1101	eng	Sunny2 Liu	2016/05/05			ecn no	ELX-DG-24036-1			
TOLERANCES UNLESS OTHERWISE SPECIFIED		chr	Terris Liu	2016/05/20			rel level	Released			
surface	ASME Y14.5	appr	Pei-Ming Zheng	2016/05/24			product family	Product - Customer Drw			
linear	0.X ±0.5 0.XX ±0.25 0.XXX ±0.10	Amphenol FCI	title		STD VERT RECPT 20P OMIT 8P HIGH POWER CARD EDGE	cat. no.	10124179		rev	B	
angular	0° ±2°	cat. no.		Product - Customer Drw		sheet 4 of 4					