

DO NOT SCALE FROM THIS PRINT

UNLESS OTHERWISE NOTED
 DIMENSIONS ARE IN INCHES TOLERANCES ARE:
 ONE PLACE DECIMALS ± .1 [2.5mm] THREE PLACE DECIMALS ± .005 [.13mm]
 TWO PLACE DECIMALS ± .010 [.25mm] FOUR PLACE DECIMALS ± .0020 [.05mm]

TITLE: 2mm TERMINAL STRIP ASSEMBLY (R/A)
 DWG NO: TMM-1XX-XX-XX-X-RA-XXX
 SHEET 1 OF 1

TMM-1XX-XX-XX-X-RA-XXX
 NO. OF POSITIONS PER ROW ——— OPTION
 -01 THRU -50 POLARIZATION SPECIFY POS -XXX AS POS TO BE OMITTED
 TERMINAL SPEC ——— OPTION
 -01: USE T-1S13-XX-X-2 -RA: RIGHT ANGLE
 BODY SPECIFICATION
 -S: SINGLE (TMM-50-S)
 -D: DOUBLE (TMM-50-D)

PLATING SPECIFICATION
 -G: 10μ" IN CONTACT AREA, 10μ" GOLD ON TAIL
 -T: MATTE TIN CONTACT AND TAIL
 -S: 30μ" SELECTIVE GOLD IN CONTACT AREA, MATTE TIN ON TAIL
 -L: 10μ" LIGHT SELECTIVE GOLD IN CONTACT AREA, MATTE TIN ON TAIL
 -F: 3μ" FLASH SELECTIVE GOLD IN CONTACT AREA, MATTE TIN ON TAIL
 -H: 30μ" HEAVY GOLD IN CONTACT AREA, 3μ" GOLD ON TAIL
 -TM: MATTE TIN CONTACT AND TAIL
 -LM: 10μ" LIGHT SELECTIVE GOLD IN CONTACT AREA, MATTE TIN ON TAIL
 -FM: 3μ" FLASH SELECTIVE GOLD IN CONTACT AREA, MATTE TIN ON TAIL
 -SM: 30μ" SELECTIVE GOLD IN CONTACT AREA, MATTE TIN ON TAIL

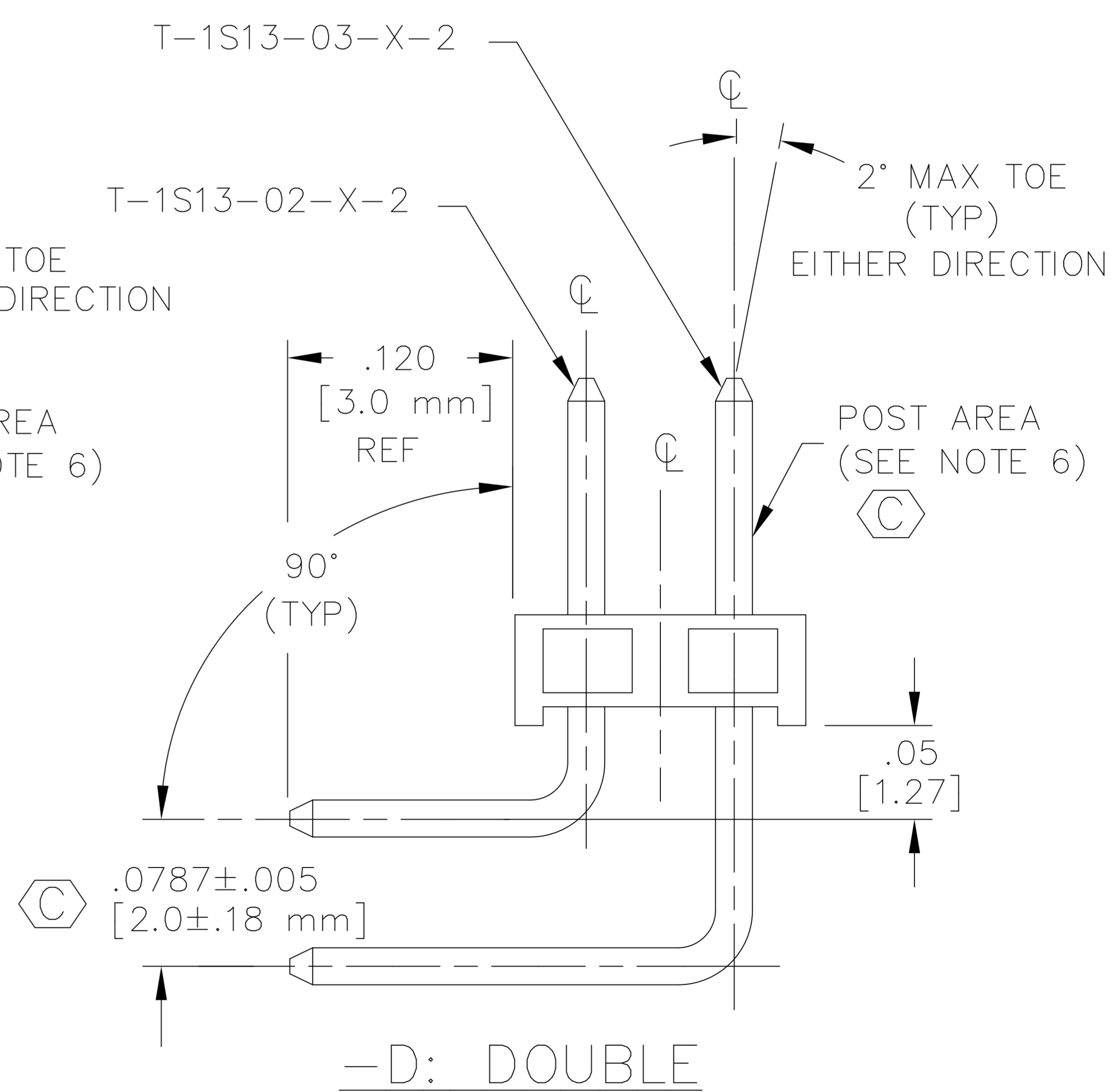
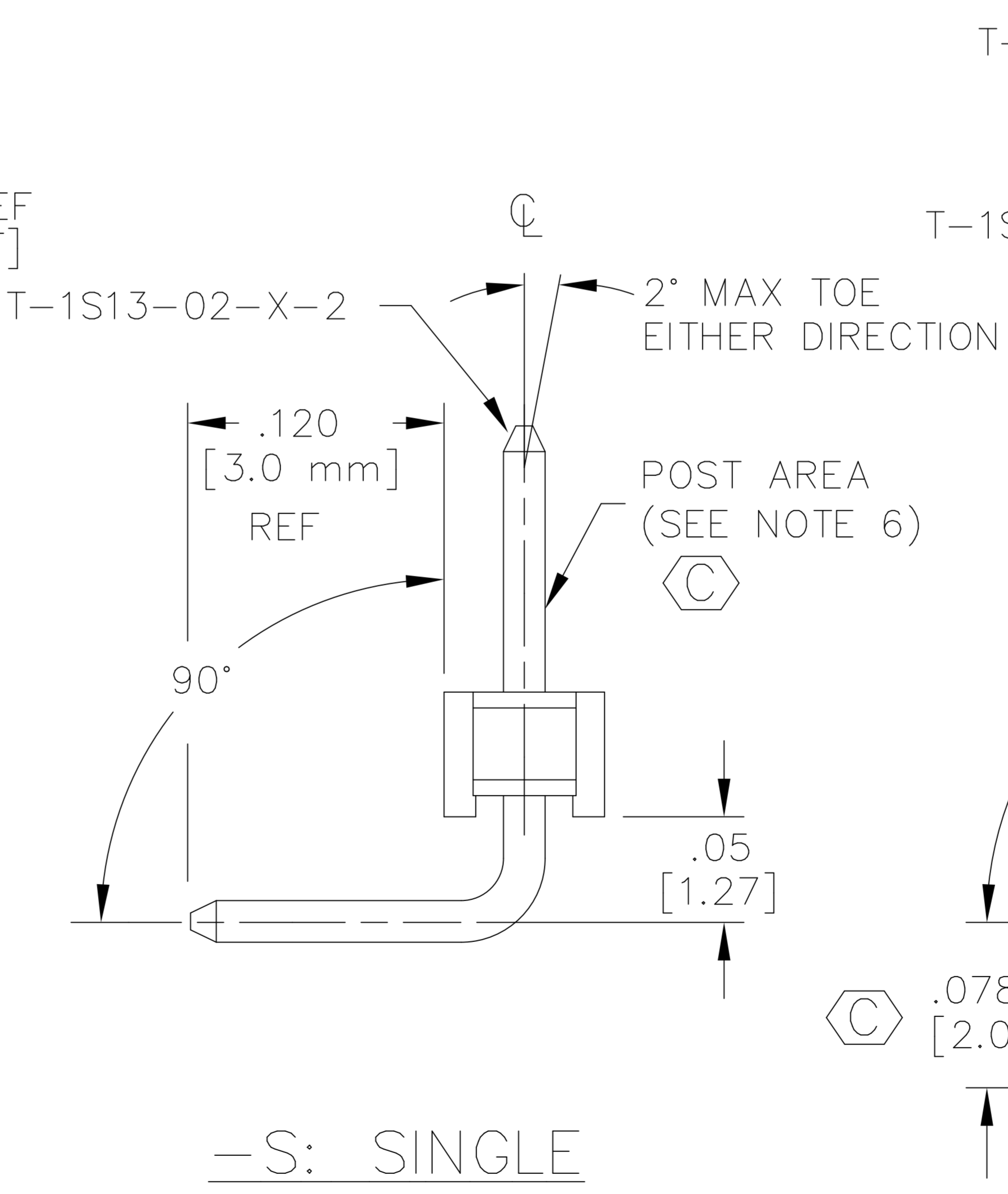
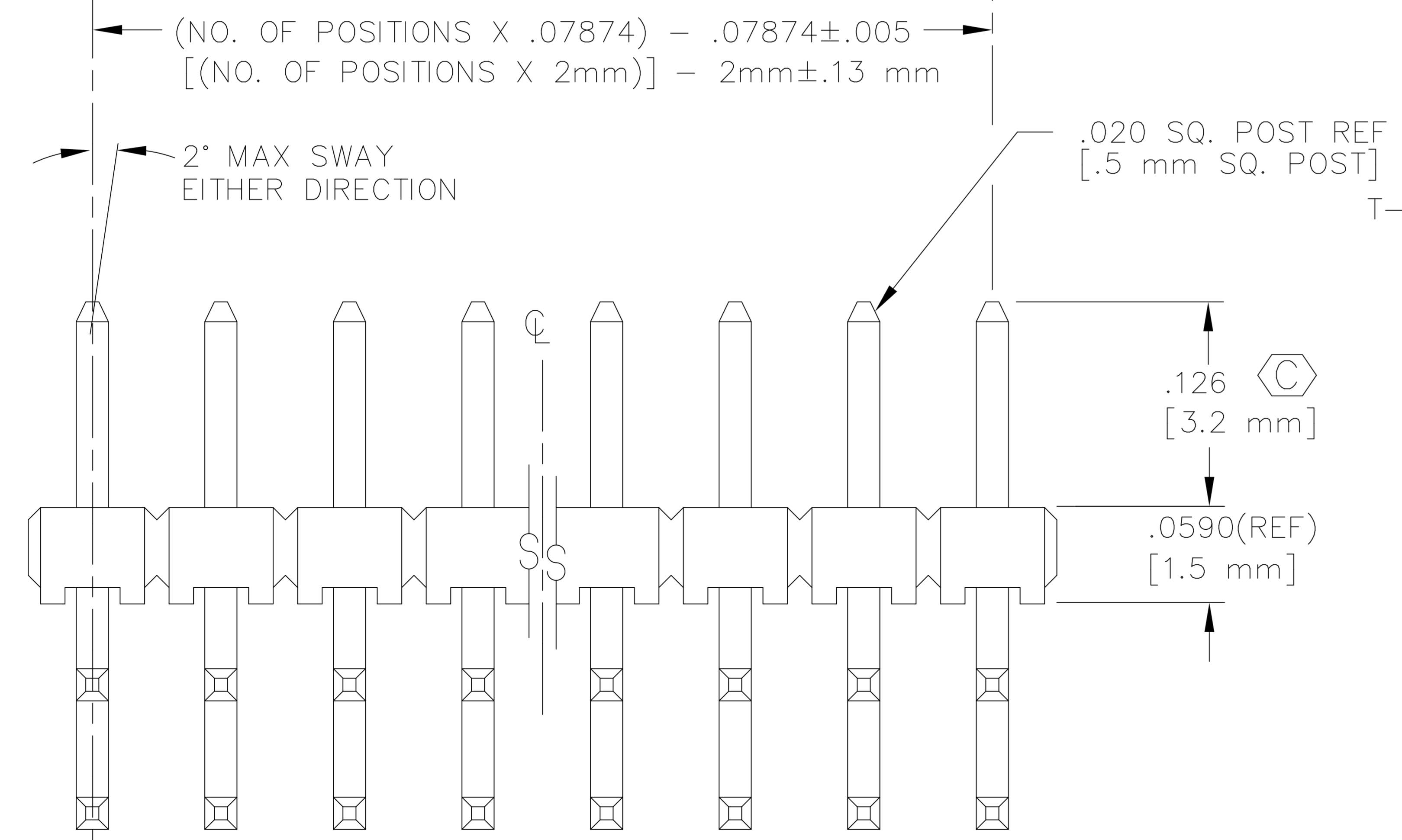
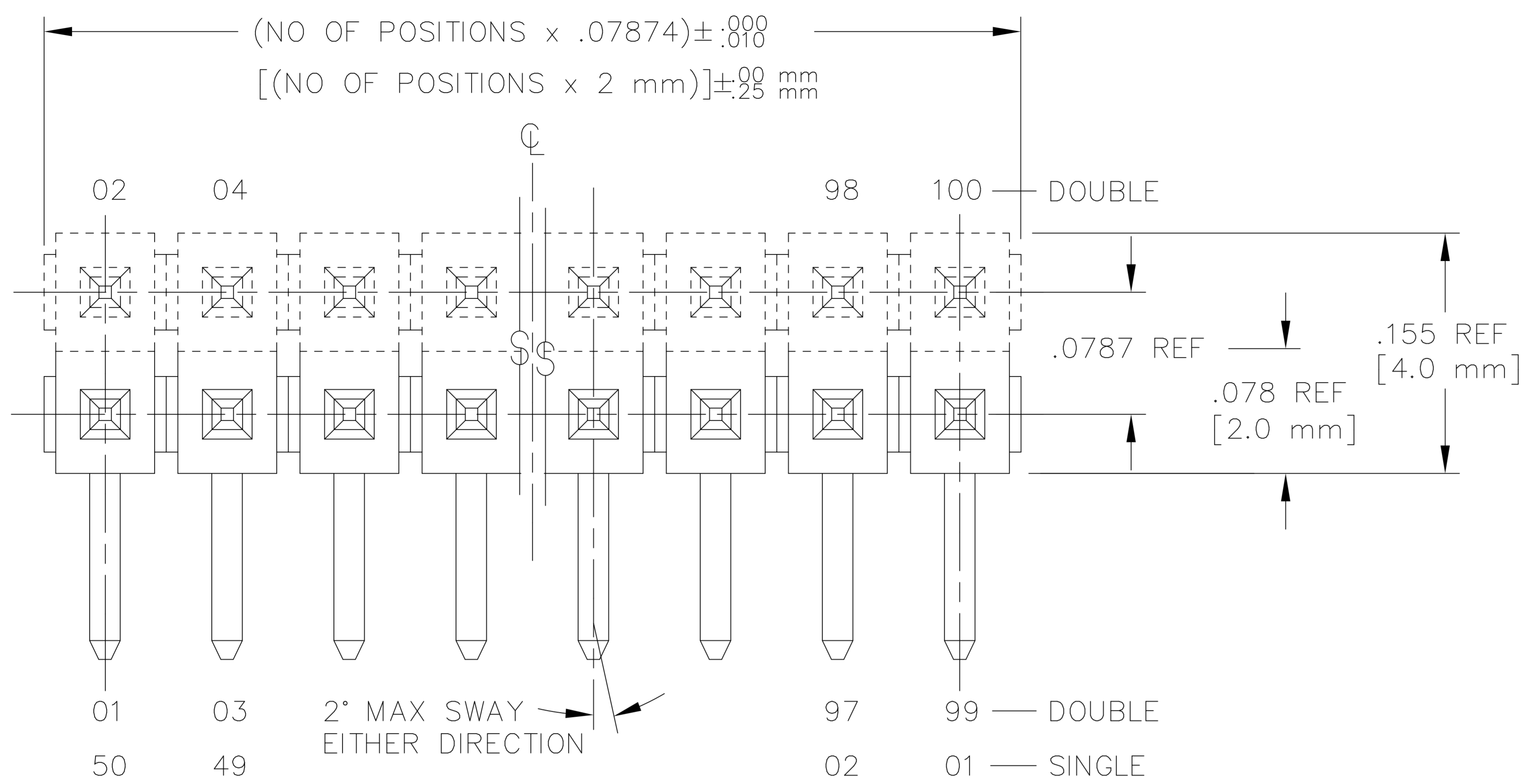

- NOTES:
1. MAX. ALLOWABLE BOW: .005 IN/IN AFTER ASSEMBLY.
 2. MAX. PIN ROTATION IN BODY: 2°
 3. PUSHOUT FORCE SHALL BE 1 lb MIN.
 4. Ⓢ REPRESENTS A CRITICAL DIMENSION FOR STATISTICAL PROCESS CONTROL USE.
 5. ALL DIMENSIONS IN BRACKETS [] TO BE MILLIMETERS.
 6. NO BANDOLIER MARKS ARE ALLOWED IN THE POST AREA.
 7. MAX CUT FLASH: .010 [.25]
 8. PIN NOT ALLOWED TO FILL FROM TAIL SIDE. PIN TO BE FILLED FROM POST SIDE.

PROPRIETARY NOTE
 THIS DOCUMENT CONTAINS INFORMATION CONFIDENTIAL AND PROPRIETARY TO SAMTEC INC. AND SHALL NOT BE REPRODUCED OR TRANSFERRED TO OTHER DOCUMENTS OR DISCLOSED TO OTHERS OR USED FOR ANY PURPOSE OTHER THAN THAT FOR WHICH IT WAS OBTAINED WITHOUT THE EXPRESSED WRITTEN CONSENT OF SAMTEC INC.

EXISPROD\ASSEMBLY\2mm TMM-RA

samtec

520 PARK EAST BLVD. NEW ALBANY, INDIANA 47150
 PHONE (812) 944-6733 P.O. BOX 1147
 CODE 55322

MADE BY: REIDINGER 5-22-91
 CHECKED BY: McCARTIN

ENG. APPROVAL DEM

TMM-1XX-XX-XX-X-RA-XXX
 SHEET 1 OF 1