

DRAWING NO.		C - 142-1403-001/010	
REVISIONS			
0			
ENGINEERING RELEASE			
1	03-02-04	TAK	ECN 49122
VERSION UPDATE			
***** * REVISION NUMBER FOLLOWED BY AN ALPHA * * CHARACTER INDICATES DRAWING CLARIFI- * * CATION OR PART NUMBER ADDITION ONLY. * *****			
1a	6-19-06	PAT	7-7-06 ECN 50503

PART NUMBER	ITEM ① BODY	ITEM ② SLIDER	ITEM ③ CONTACT	ITEM ④ INSULATOR	ITEM ⑤ RETENTION SPRINGS	ITEM ⑥ COUPLING NUT	ITEM ⑦ CRIMP SLEEVE
142-1403-001	BRASS GOLD PL .00001 MIN OVER NICKEL PL .00005 MIN OVER COPPER PL .00005 MIN	BRASS NICKEL PL .0001 MIN OVER COPPER PL .00005 MIN	BERYLLIUM COPPER GOLD PL .00005 MIN OVER NICKEL PL .00005 MIN OVER COPPER PL .00005 MIN	TEFLON	BERYLLIUM COPPER UNPLATED	BERYLLIUM COPPER NICKEL PL .0001 MIN OVER COPPER PL .00005 MIN	COPPER NICKEL PL .0001 MIN OVER COPPER PL .00005 MIN

**INSTRUCTIONS FOR USE:**

- WITH SLIDER AT THE ENGAGED POSITION, THE CONNECTOR FUNCTIONS LIKE A STANDARD SMA CONNECTOR. TIGHTEN (SPIN) THE KNURLED COUPLING NUT BY HAND TO OBTAIN FULL MATING ENGAGEMENT OR DISENGAGEMENT.
- QUICK CONNECT:
  - WITH SLIDER AT THE DISENGAGED POSITION, SLIDE THE CABLED CONNECTOR ONTO AN SMA JACK RECEPTACLE, OVER THE JACK THREADS BY PUSHING ON THE BACK OF THE KNURLED NUT.
  - ENGAGE THE SLIDER WHILE MAINTAINING LIGHT FORWARD PRESSURE ON THE NUT. THIS ACTION IS DONE BY SLIPPING YOUR FINGERS FROM THE NUT TO THE SLIDER IN ONE MOTION.
  - ONCE THE SLIDER IS ENGAGED THE KNURLED NUT CAN BE TURNED 1 TURN OR LESS TO OBTAIN FULL ENGAGEMENT SMA PERFORMANCE.
  - DISENGAGE THE CONNECTOR BY FIRST LOOSENING THE KNURLED NUT A PARTIAL TURN. THEN DISENGAGE THE SLIDER AND REMOVE THE CONNECTOR.

**CAUTION:**

- THIS SMA PLUG CONNECTOR IS DESIGNED FOR HIGH DURABILITY AND LONG LIFE IN TEST APPLICATIONS. HOWEVER, IT IS DESIGNED FOR LIMITED MATINGS WITH A SINGLE JACK RECEPTACLE. AN SMA JACK RECEPTACLE MAY EXPERIENCE THREAD PLATING WEAR AFTER MANY ENGAGEMENTS.

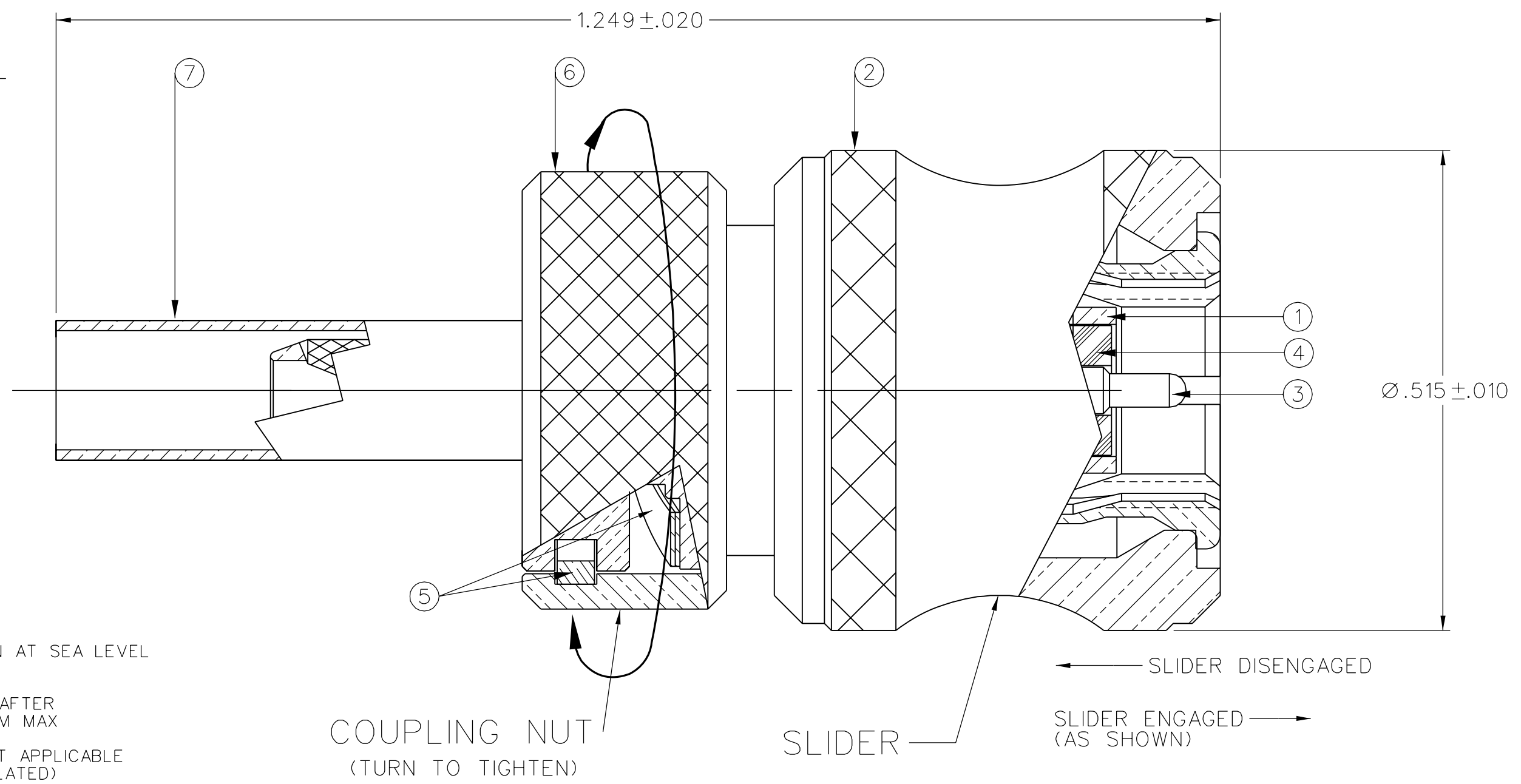

**NOTES:**

- SPECIFICATIONS:
  - IMPEDANCE: 50 OHMS
  - FREQUENCY RANGE: 0-12.4 GHz
  - VSWR: 1.15+.02 F MAX (F IN GHz)
  - WORKING VOLTAGE: 250 VRMS MAX AT SEA LEVEL
  - DIELECTRIC WITHSTANDING VOLTAGE: 750 VRMS MIN AT SEA LEVEL
  - INSULATION RESISTANCE: 5000 MEGOHM MIN
  - CONTACT RESISTANCE:
    - CENTER CONTACT - INITIAL 3.0 MILLIOHM MAX, AFTER ENVIRONMENTAL 4.0 MILLIOHM MAX
    - OUTER CONDUCTOR - INITIAL 2.0 MILLIOHM MAX AFTER ENVIRONMENTAL NOT APPLICABLE
    - BODY TO CABLE - 0.5 MILLIOHM MAX (GOLD PLATED) 5.0 MILLIOHM MAX (NICKEL PLATED)
  - CORONA LEVEL: 190 VOLTS MIN AT 70,000 FEET
  - INSERTION LOSS: .06 √ F dB MAX (F IN GHz) AT 6 GHz
  - RF LEAKAGE: -60 DB MIN AT 2.5 GHz
  - RF HIGH POTENTIAL WITHSTANDING VOLTAGE: 500 VRMS MIN AT 4 AND 7 MHz

**MECHANICAL:**

- ENGAGE/DISENGAGE TORQUE: 2 INCH-POUNDS MAX
- MATING TORQUE: 7-10 INCH POUNDS
- COUPLING PROOF TORQUE: 15 INCH-POUNDS MIN
- COUPLING NUT RETENTION: 60 LBS MIN
- CONTACT RETENTION: 6 LBS MIN
- CABLE ACCEPTABILITY: RG 188/U, RG 316/U, RG 161/U, RG 174/U
- CABLE HEX CRIMP SIZE: .128
- CABLE RETENTION: 20 LBS MIN AXIAL FORCE
- DURABILITY: 500 CYCLES MIN

**ENVIRONMENTAL:**

- (MEETS OR EXCEEDS THE APPLICABLE PARAGRAPH OF MIL-PRF-39012)
- THERMAL SHOCK: MIL-STD-202, METHOD 107, CONDITION B, EXCEPT 85° C HIGH TEMP
- OPERATING TEMPERATURE: -65° C TO 165° C
- CORROSION: MIL-STD-202, METHOD 101, CONDITION B
- SHOCK: MIL-STD-202, METHOD 213, CONDITION I
- VIBRATION: MIL-STD-202, METHOD 204, CONDITION D
- MOISTURE RESISTANCE: MIL-STD-202, METHOD 106

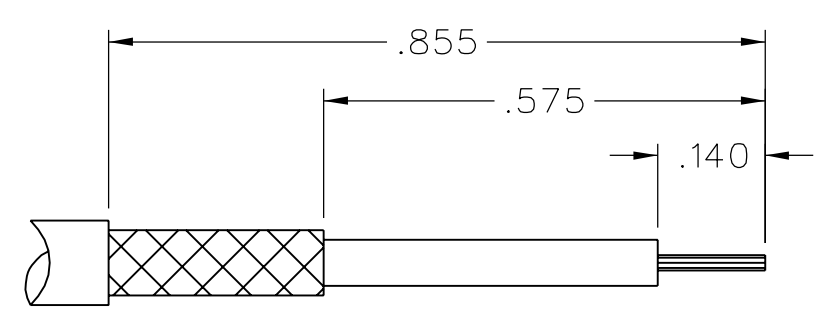

**CABLE STRIP DIMENSIONS**

4:1

TOLERANCE UNLESS OTHERWISE SPECIFIED		DRAWN BY	DATE
DECIMALS	mm	T.A.Kari	9-1-03
.XX	_____	CHECKED BY	DATE
.XXX	_____		
MATL	_____	APPROVED BY	DATE
		T.A.Kari	9-1-03
FINISH	_____	RELEASE DATE	32-04
		U/M	INCH
		SCALE	8:1

**cinch** Connectivity Solutions  
P.O. Box 1732  
Waseca, MN 56093  
1-800-247-8256

TITLE  
STRAIGHT PLUG CABLE  
SMA, QUICK CONNECT COUPLING,  
CRIMP TYPE, RG-316

SHEET	DRAWING NO.
2 OF 2	C - 142-1403-001/010

**CUSTOMER DRAWING**

THIS DRAWING TO BE INTERPRETED PER ASME Y 14.5M - 1994

"μSTATION"

**COMPANY CONFIDENTIAL**