

10 9 8 7 6 5 4 3 2 1

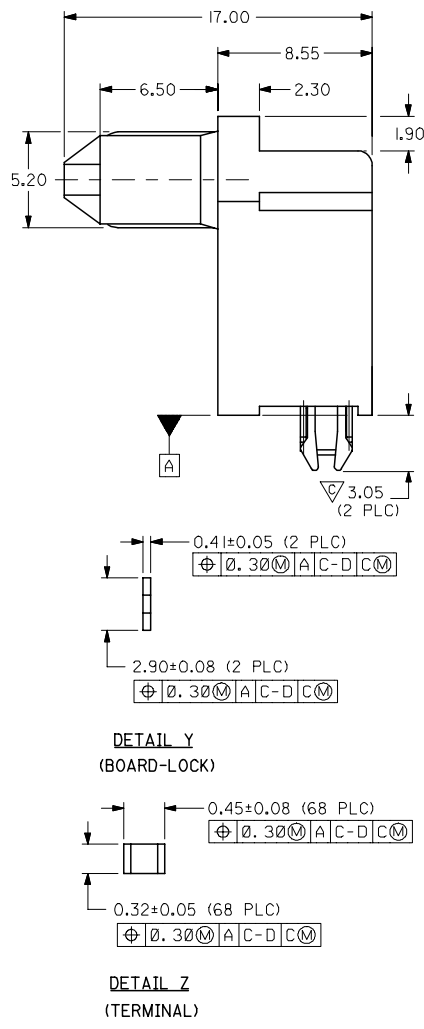
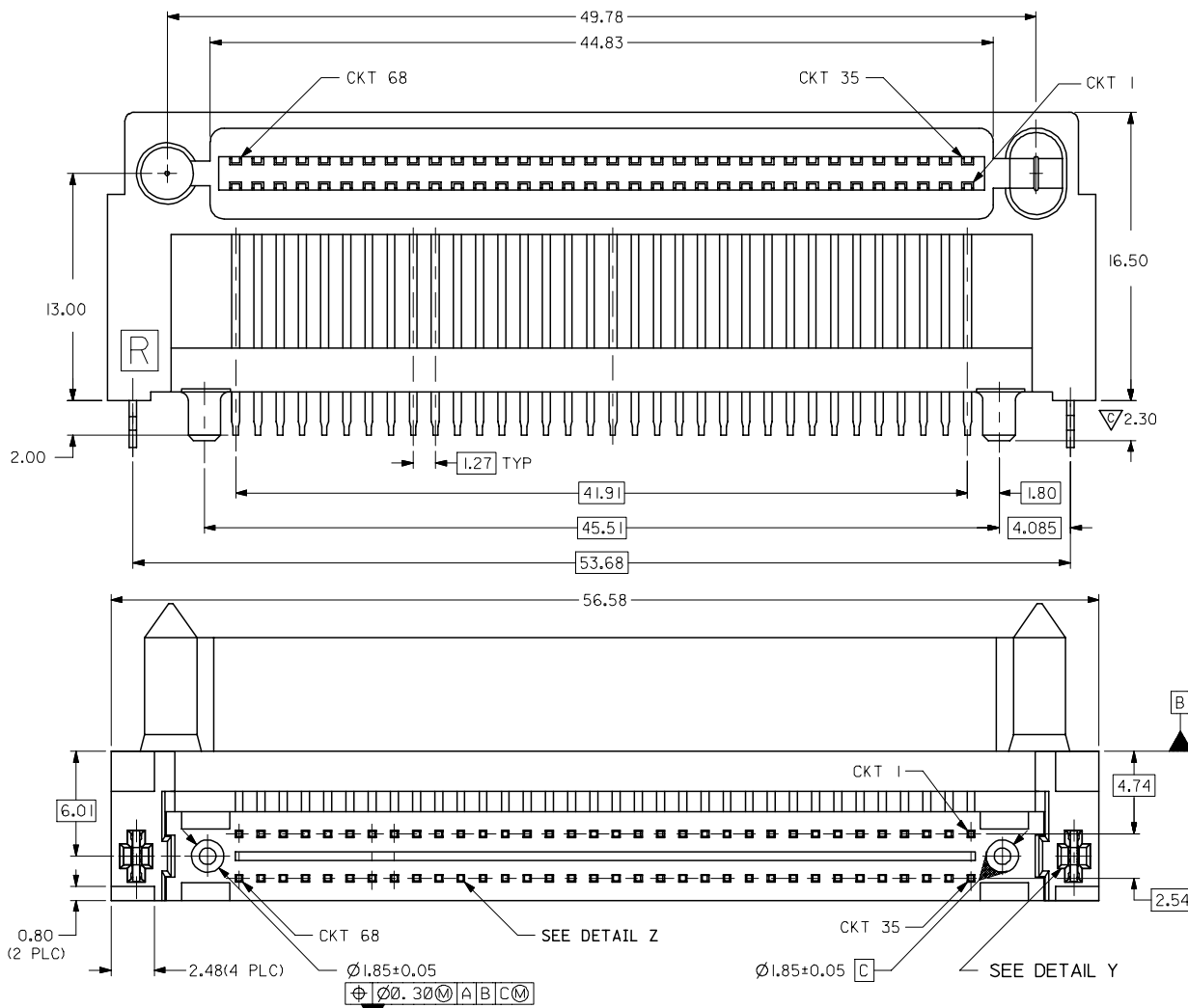

PART NO. (PACKED IN CARTON)	CKT SIZE	CONTACTS LUBRICATION
87537-8876	68	YES
87537-8877	68	NIL

OBS TIN/LEAD P/N  
 EC NO: S2006-0729  
 DRWN:MLONG 2006/02/27  
 CHKD:SHONG 2006/02/27  
 APPR:KCLING 2006/02/28

QUALITY SYMBOLS  
 $\nabla=0$   
 $\nabla=2$

	GENERAL TOLERANCES (UNLESS SPECIFIED)	
	mm	INCH
4 PLACES	± ---	± ---
3 PLACES	± ---	± ---
2 PLACES	± 0.25	± ---
1 PLACE	± ---	± ---
ANGULAR		± 3°

DRAFT WHERE APPLICABLE  
 MUST REMAIN WITHIN DIMENSIONS

DIMENSION STYLE		SCALE	DESIGN UNITS	THIRD ANGLE PROJECTION
MM ONLY		NTS	METRIC	
DRAWN BY	DATE	TITLE		
RSHAN	2003/11/03	EBBI, RECEPTACLE, CONN. 1.27MM CTR, 68 CKTS, BTB RVS B/M, 13MM HT., R/A		
CHECKED BY	DATE	MOLEX INCORPORATED		
KCLING	2003/11/14	SD-87537-032		
APPROVED BY	DATE	SHEET NO.		
SKTOH	2003/11/14	1 OF 2		
MATERIAL NO.	DOCUMENT NO.	THIS DRAWING CONTAINS INFORMATION THAT IS PROPRIETARY TO MOLEX INCORPORATED AND SHOULD NOT BE USED WITHOUT WRITTEN PERMISSION		
SEE TABLE	SD-87537-032			

9 8 7 6 5 4 3 2 1

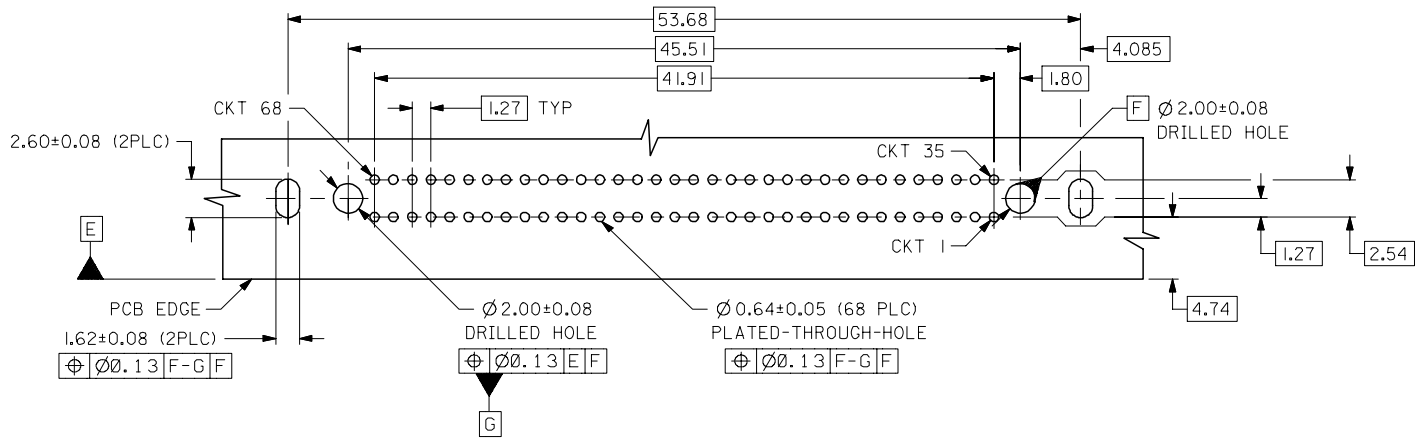

RECOMMENDED PC BOARD LAYOUT  $\triangle$   
COMPONENT SIDE

NOTES:

- 1 MATERIALS:  
HOUSING - HIGH TEMPERATURE THERMOPLASTIC, GLASS FILLED,  
UL94V-0, COLOR : BLACK  
TERMINAL - COPPER ALLOY
- 2 PLATING:  
0.76µm MIN. GOLD IN SELECTIVE CONTACT AREA AND  
2.54µm MIN. TIN IN SOLDER TAIL AREA, BOTH  
OVER 1.27µm MIN. NICKEL.
- 3. PRODUCT SPECIFICATION : PS-87537-0001
- $\triangle$  RECOMMENDED P.C. BOARD THICKNESS IS 1.57+/-0.05MM.
- 5 CIRCUIT #58 TO BE RECESSED 0.50mm BEHIND  
ALL OTHER CONTACTS.
- $\triangle$  PART IS LUBRICATED AT TERMINAL CONTACTS TO MINIMISE  
UNMATE FORCE.

OBS TIN/LEAD P/N EC NO: S2006-0729 DRWN:MLONG 2006/02/27 CHKD:SHONG 2006/02/27 APPR:KCLING 2006/02/28	QUALITY SYMBOLS $\nabla=0$ $\triangle=0$	GENERAL TOLERANCES (UNLESS SPECIFIED)		DIMENSION STYLE MM ONLY		SCALE NTS	DESIGN UNITS METRIC	THIRD ANGLE PROJECTION		
			mm	INCH	DRAWN BY RSHAN	DATE 2003/11/03	TITLE EBBI, RECEPTACLE, CONN. 1.27MM CTR, 68 CKTS, BTB RVS B/M, 13MM HT., R/A			
		4 PLACES	± ---	± ---	CHECKED BY KCLING	DATE 2003/11/14				
		3 PLACES	± ---	± ---	APPROVED BY SKTOH	DATE 2003/11/14	MOLEX INCORPORATED			
	2 PLACES	± 0.25	± ---	MATERIAL NO.		DOCUMENT NO.	SHEET NO.			
	1 PLACE	± ---	± ---	SEE TABLE		SD-87537-032	2 OF 2			
DRAFT WHERE APPLICABLE MUST REMAIN WITHIN DIMENSIONS		SIZE A3				THIS DRAWING CONTAINS INFORMATION THAT IS PROPRIETARY TO MOLEX INCORPORATED AND SHOULD NOT BE USED WITHOUT WRITTEN PERMISSION				