

LOC		DIST		REVISIONS			
A	66	P	LTN	DESCRIPTION	DATE	DMN	APVD
		-		SEE SHEET 1			

FEED TYPE PNEUMATIC

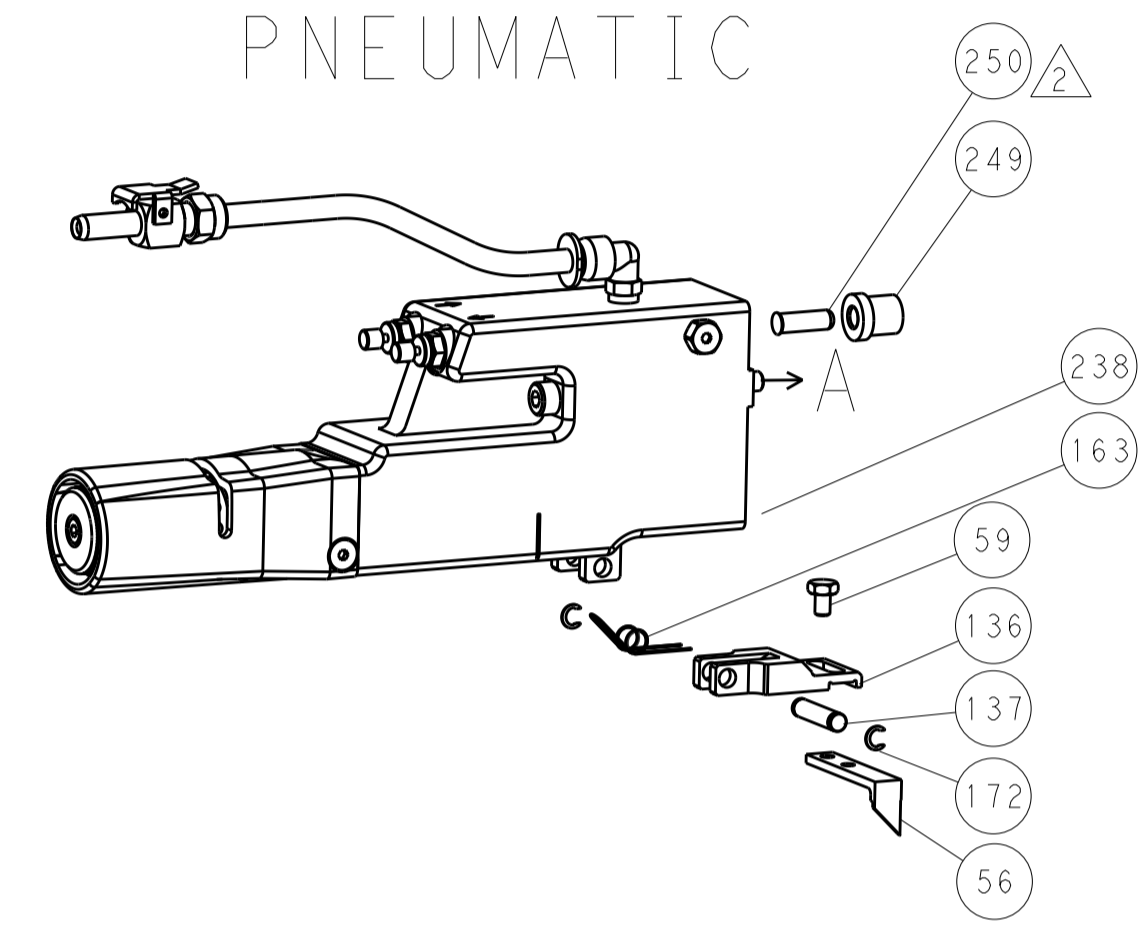

SERVO LATCH PLATE

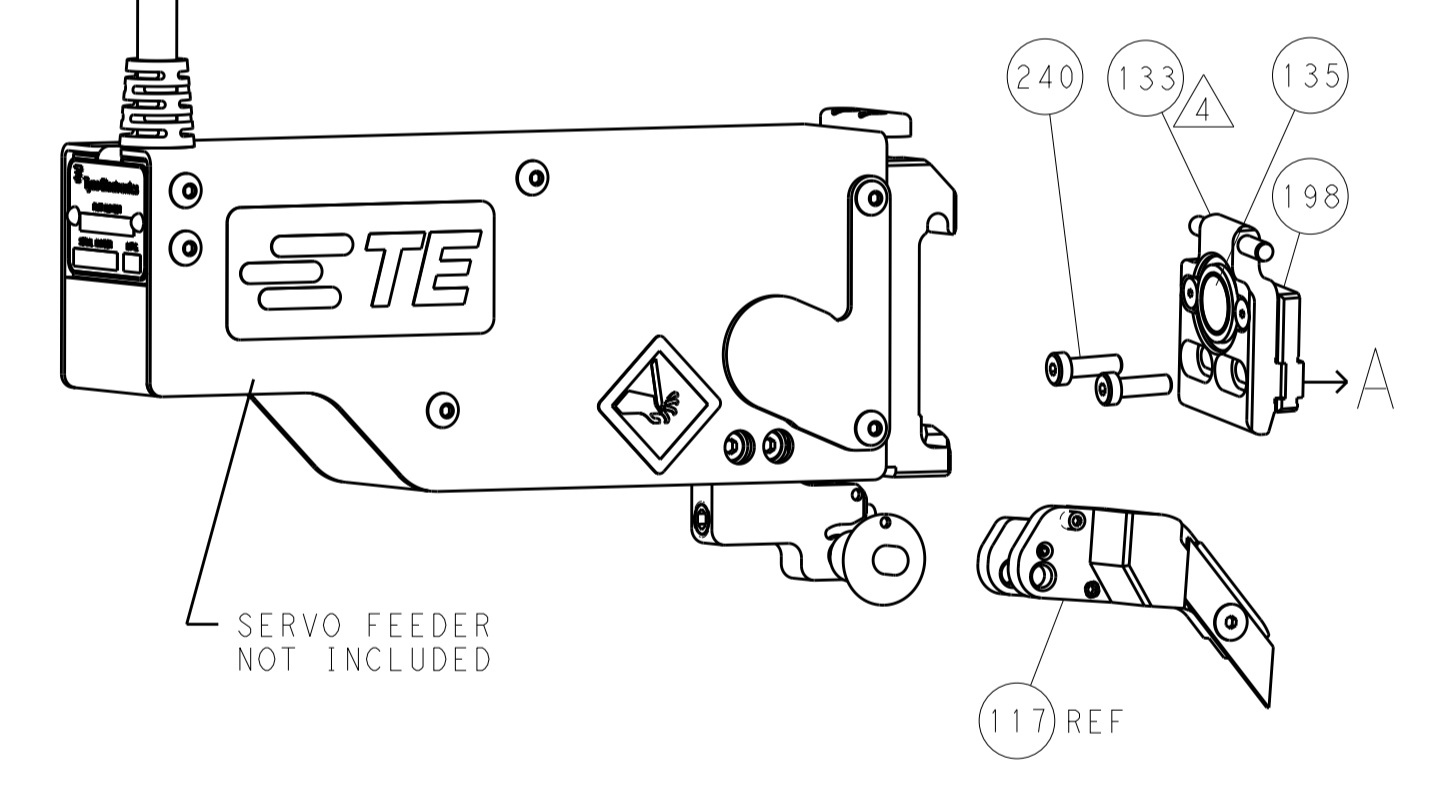

CAM POSITIONS

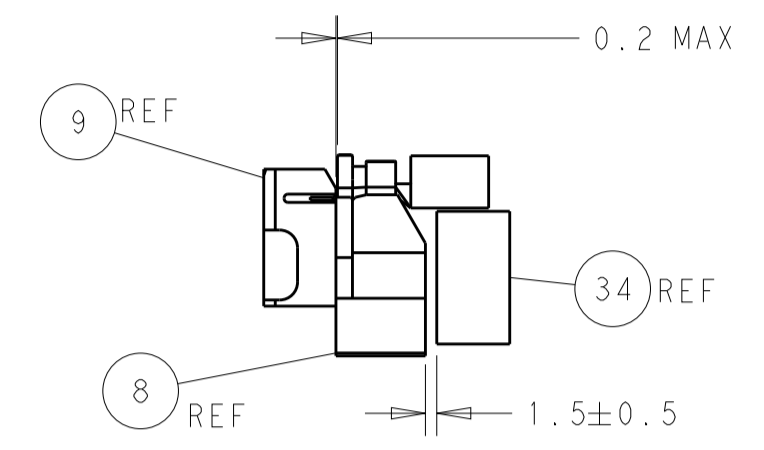
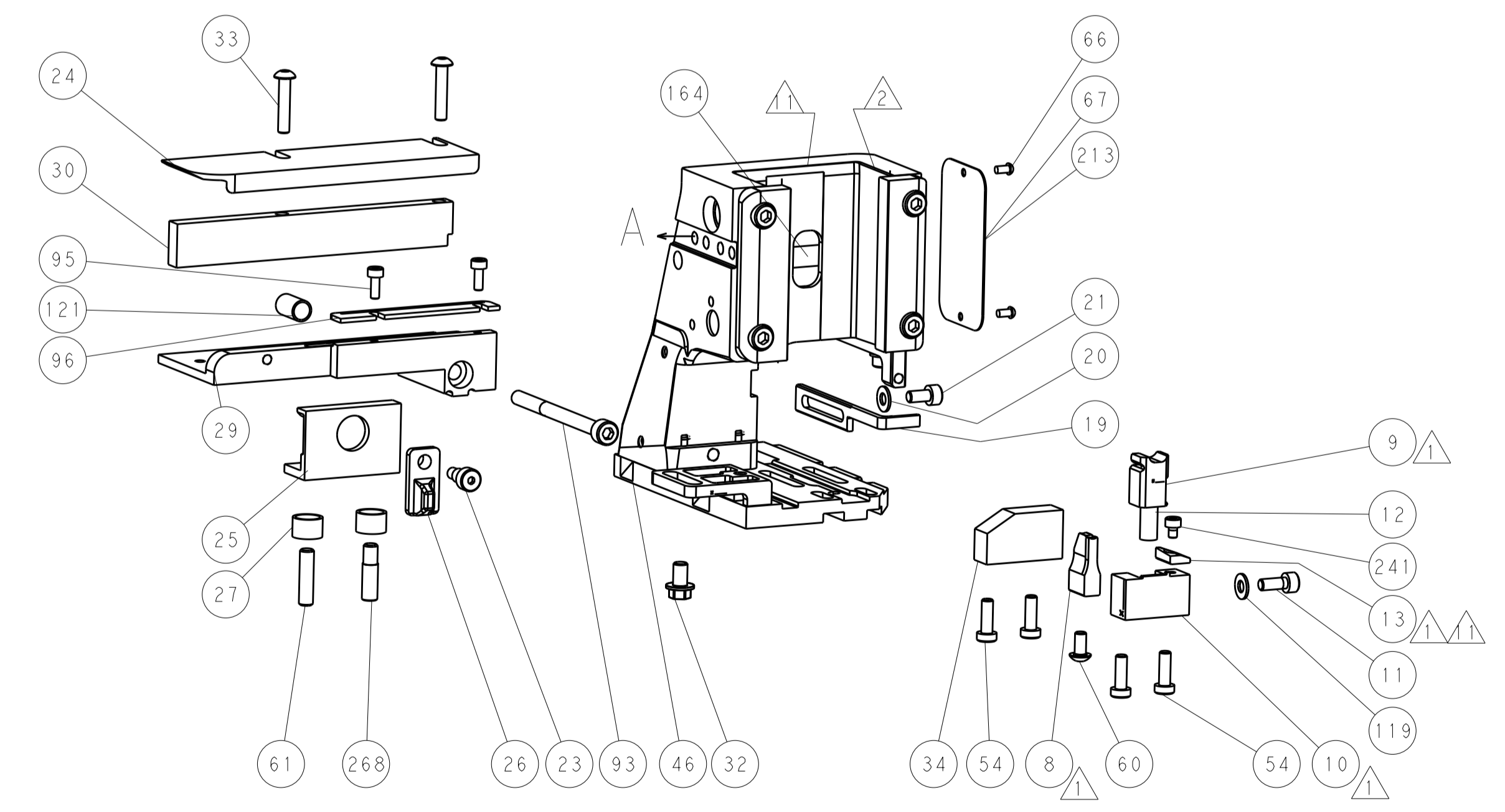
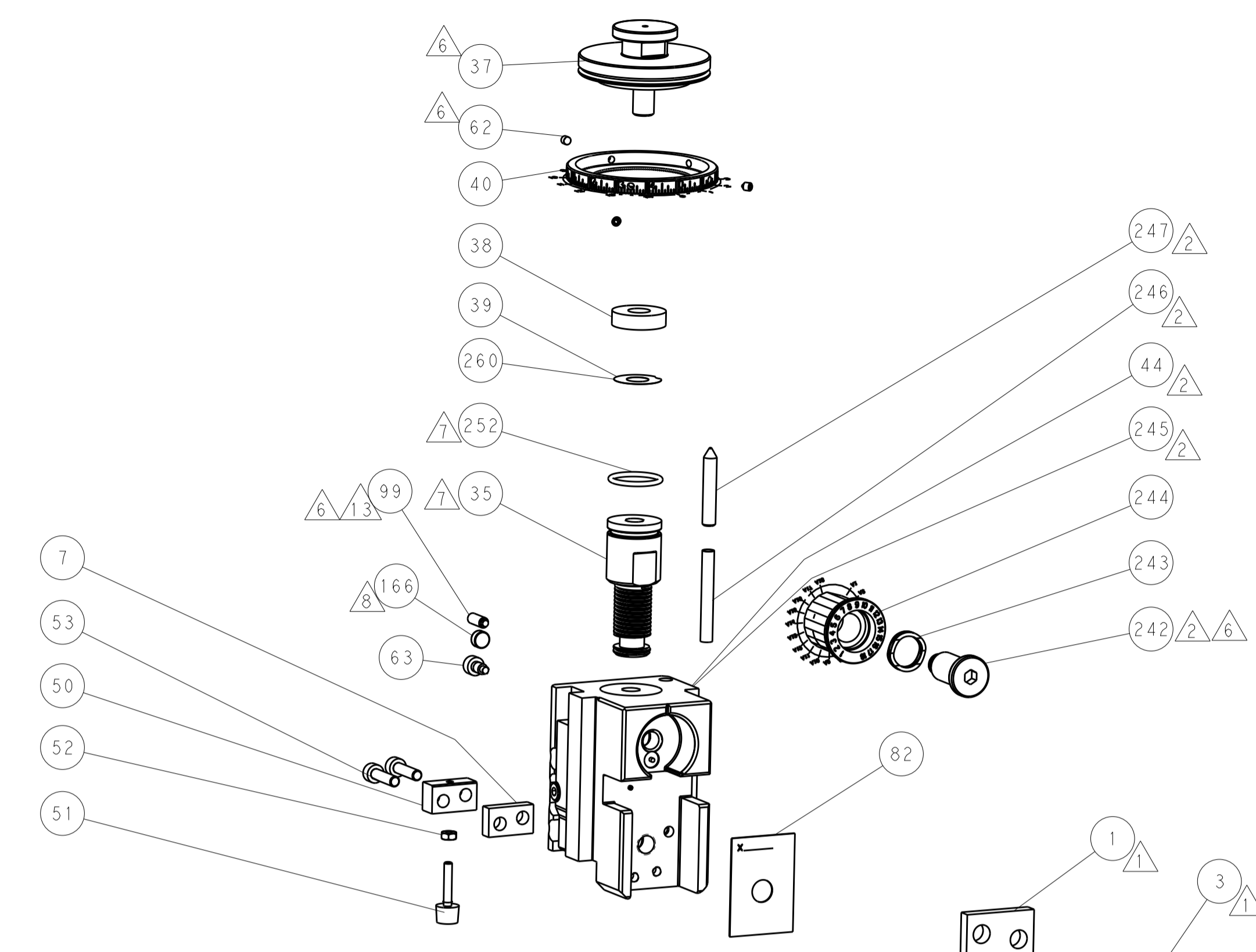
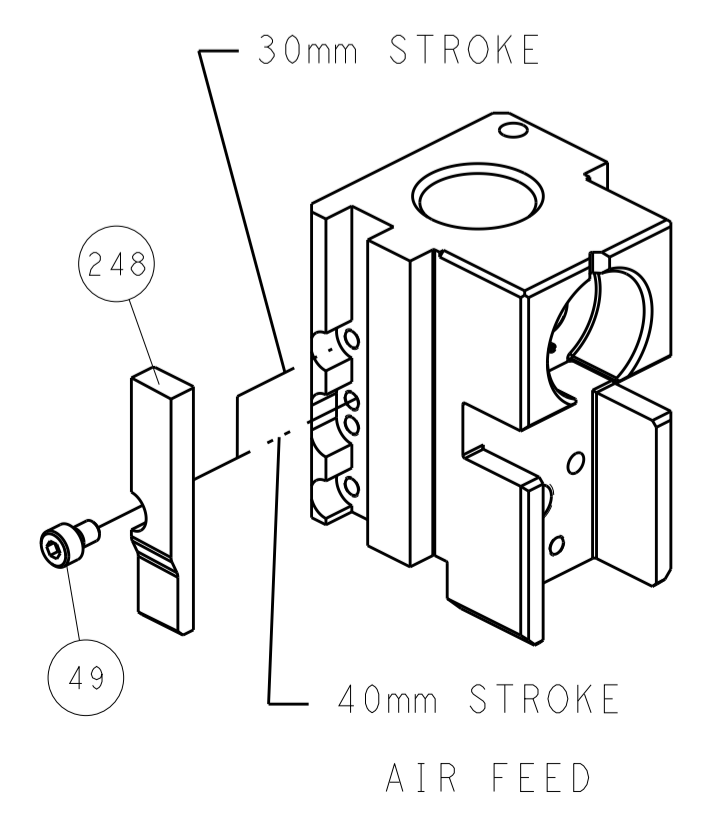

TERMINAL SUPPORT LOCATION

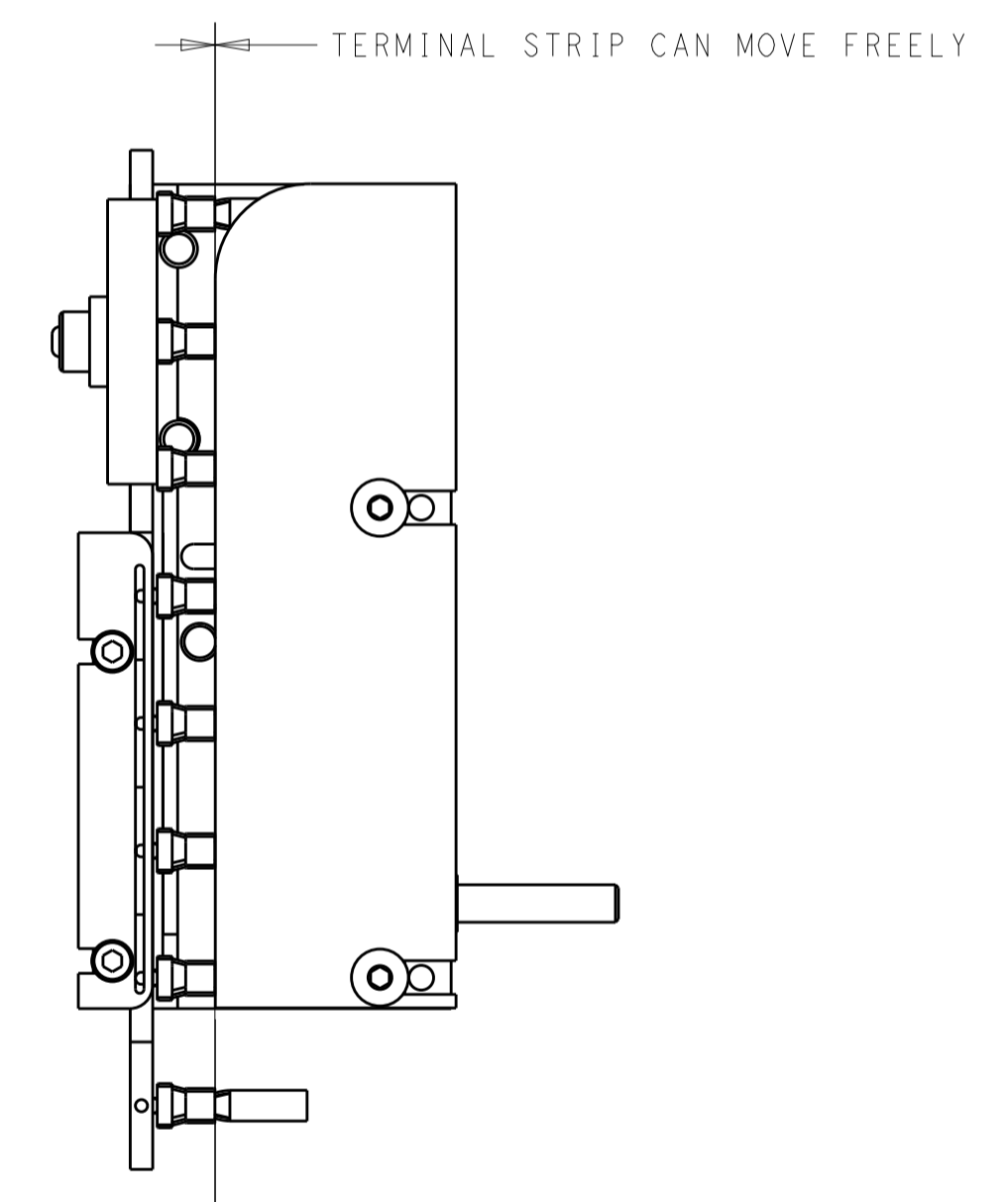

FEED TRACK POSITION

ITEM 30 LOCATED AT REAR HOLES

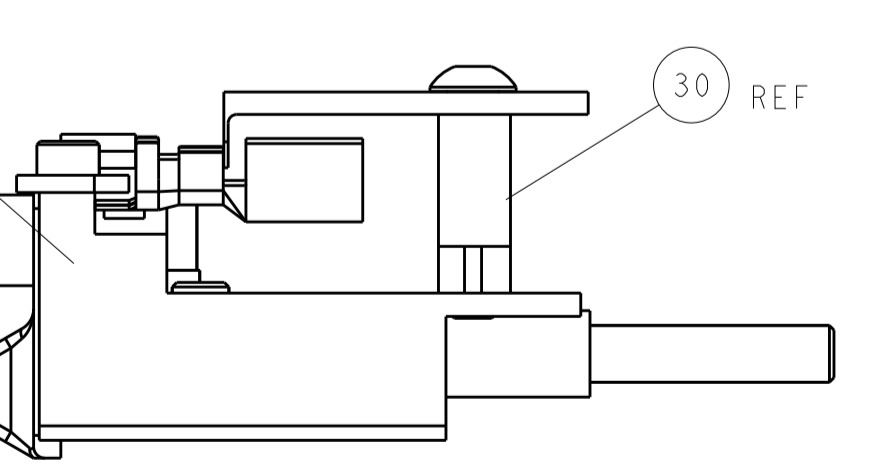

FEED TRACK POSITION GUIDE BY WIRE BARREL

ATLANTIC VERSION
 Shown on sheets 1 of 4 & 2 of 4
 (Pacific version shown on sheets 3 of 4 & 4 of 4)



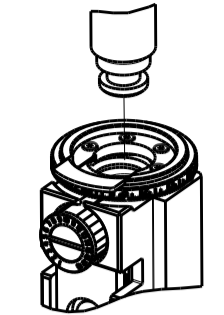



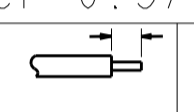

DIMENSIONS:		TOLERANCES UNLESS OTHERWISE SPECIFIED:		DWG: R. KNEPPER 18JAN2012		TE Connectivity	
mm	0 PLC ±	1 PLC ±	2 PLC ±	3 PLC ±	4 PLC ±	ANGLES ±	TE Connectivity Harrisburg, PA 17105-3608
MATERIAL:	FINISH:	WEIGHT:	SCALE:	SIZE: A1	CAGE CODE: 00779	DRAWING NO: C=2151550	RESTRICTED TO:
			1:2				
Customer Accessible Production Drawing				SHEET 2 OF 4	REV F		

PACIFIC VERSION TERMINATOR INTERFACE ADAPTER	PART NUMBER	REVISION	DESCRIPTION	FEED TYPE	APPLICATOR STYLE CONVERSION CHART					
					CONVERT TO	PART NUMBERS REQUIRED				
	2-2151550-2	F	FINE CRIMP HEIGHT ADJUST	PNEUMATIC	-	-	-	-	-	-
					SERVO LATCH PLATE	2119951-1	-	8-2151550-5	1901094-3	2168400-6 (QUANTITY 2)
					SMART APPLICATOR	2161326-1	-	8-2151550-4	-	-
	2-2151550-5	F	FINE CRIMP HEIGHT ADJUST	SERVO LATCH PLATE ⁴	-	-	-	-	-	-
2-2151550-7	F	FINE CRIMP HEIGHT ADJUST	NONE	-	-	-	-	-	-	
7-2151550-7	A	CRIMP TOOLING KIT	-	-	-	-	-	-	-	

APPLICATOR DATA		
CRIMP	SIZE	TYPE
WIRE	2.79 mm [.110]	F
INSUL	3.56 mm [.140]	F
APPLICATOR INSTRUCTIONS 408-10389		

TERMINAL DATA: TE TERMINAL		TE CRIMP SPECIFICATION
TERMINAL NAME: AMP MCP 6.3/4.8 K LITEALUM CONTACT		
WIRE STRIP LENGTH 3.40-4.00 mm [.134-.157 IN]		INSULATION DIAMETER RANGE Ø2.88-3.04 mm [.113-.120 IN]
TERMINAL APPLICATION SPECIFICATION 114-94204	-	-
TERMINALS APPLIED ¹⁰		
TE TERMINAL	TE TERMINAL	TE TERMINAL
2-2177838-1		

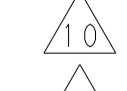
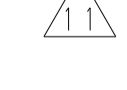
WIRE SIZE	CRIMP HEIGHT mm [INCH]	CRIMP HEIGHT REFERENCE SETTING
2.50mm2	1.77±0.04 [.0697±.0016]	7.2







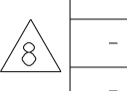

-  RECOMMENDED SPARE PARTS
-  GREASE BEARING SURFACES LIGHTLY
- 3. LUBRICATE DAILY PER THE APPLICATOR INSTRUCTION SHEET SUPPLIED WITH THE APPLICATOR.
-  APPLICATOR SPECIFIC DATA TO BE ENTERED INTO BLANK MEMORY CHIP AT ASSEMBLY. SEE BELOW FOR PART NUMBER:
 PNEUMATIC FEED WITH "SMART APPLICATOR" CONVERSION: 8-2151550-4
 SERVO FEED WITH "FINE CRIMP HEIGHT ADJUST": 8-2151550-5
- 5. ADJUSTMENT OF THE STRIPPER MAY BE REQUIRED WHEN MOVING THE APPLICATOR BETWEEN BENCH AND LEADMAKER APPLICATIONS.
-  APPLY PART NUMBER 1-23419-5 LOCTITE TO THREADS OF ITEMS 62.
 APPLY PART NUMBER 2-23419-6 LOCTITE TO THREADS OF ITEMS 99 & 242.
-  GREASE THREADS, GROOVE AND O-RING ON ITEMS 139 & 152.
-  MAGNET MUST BE ORIENTED CORRECTLY IN ORDER TO PROPERLY ACTUATE THE COUNTER.
-  CRIMP HEIGHT REFERENCE SETTING WAS THE SETTING USED WHEN THE APPLICATOR WAS QUALIFIED AT THE FACTORY. ADJUSTMENT MAY BE NECESSARY WHEN RUNNING APPLICATOR IN THE FIELD.
-  TERMINAL PITCH NOT COMPATIBLE WITH MECHANICAL FEED.
-  TO CONVERT THE APPLICATOR TO A NON-CARRIER CUTTING STYLE, REMOVE ITEM 13 AND ATTACH TO THE LOCATION ON BACK SIDE OF THE HOUSING. REFER TO INSTRUCTION SHEET FOR ADDITIONAL INFORMATION.
-  SET THE FINE CRIMP HEIGHT ADJUSTMENT HEAD TO PROPER CRIMP HEIGHT PRIOR TO TIGHTENING/LOCKING THE BRASS TIP SET SCREW, ITEM 99, AGAINST THE ADJUSTMENT BOLT THREADS.
- 13. APPLICATOR TO BE USED IN CONJUNCTION WITH LEADMAKER INTIGRATION KIT, P/N 2280475-1 FOR CLAMPING AND SENSING OF FEED TRACK.

***WARNING**
 ON INSTALLATION, SET WIRE DISC, ITEM 40 TO LARGEST WIRE SIZE SETTING. USE OF SETTINGS BELOW MINIMUM REQUIRED CRIMP HEIGHT SETTING WILL CAUSE DAMAGE TO CRIMP TOOLING.

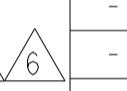
-	1	1	1	2-1722335-1	THREAD BOLT GEWINDEBOLZEN	268
-	1	1	1	2119782-1	FINE ADJUST HEAD ASM, PACIFIC STYLE	251
-	-	-	1	2119640-1	PUSH ROD, AIR FEED	250
-	-	-	1	2079988-1	BUSHING, LCH5-12, MISUMI	249
-	1	1	1	1-22279-3	SPRING, COMPRESSION	246
-	1	1	1	2119082-4	CAM, SNAIL, INSULATION ADJUSTMENT	244
-	1	1	1	2079764-1	WASHER, WAVE SPRING, CREST-TO-CREST	243
-	1	1	1	2119083-1	RETAINER, INSULATION DIAL	242
-77	-27	-25	-22	PART NO	DESCRIPTION	ITEM NO

PACIFIC VERSION
 Shown on sheets 3 of 4 & 4 of 4
 (Atlantic version shown on sheets 1 of 4 & 2 of 4)

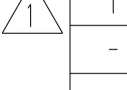
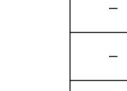
SET UP GAUGE	LOC	DIST	REVISIONS			
2119599-1	A	66	REV	DATE	BY	APPV
			-	SEE SHEET 1	-	-

-	1	1	1	7-18023-7	SCR, SKT HD CAP M3 X 4.0	241
-	-	2	-	2168400-6	SHCS, LOW HEAD, RoHS, M5 X 16	240
-	-	-	1	2063440-1	AIR FEED MODULE	238
-	-	-	1	2119740-2	TAG, IDENTIFICATION	213
-	-	-	1	1901094-3	SPACER, FEEDER	198
-	-	-	2	21045-3	RING, RETAIN, EXTERN, 3/16 CRESCENT	172
	1	1	1	994969-1	MAGNET, RARE EARTH HIGH ENERGY	166
-	REF	REF	REF	994970-2	COUNTER, MAGNETIC	164
-	-	-	1	240638-1	SPRING, FEED FINGER	163
	1	1	1	8-21084-1	O-RING, .801 ID, .070 DIA. MAT.	152
-	-	-	1	2119641-2	FEED CAM, AIR FEED	151
-	1	1	1	2119798-2	DETENT PIN	145
-	1	1	1	2079383-8	SCR, BHSC, RoHS (M4 X 16)	144
-	4	4	4	2168400-5	SHCS, LOW HEAD, RoHS, M4 X 20	143
-	1	1	1	2-2119656-4	APPLICATOR BASIC ASSEMBLY, SF	141
-	1	1	1	2119650-1	RAM, ASIAN STYLE, SIDE FEED	140
	1	1	1	2119092-2	BOLT, ADJUSTMENT	139
-	-	-	1	3-23627-7	PIN, RETAIN, GRVD, 3/16 X .854	137
-	-	-	1	2119799-1	HOLDER, FEED FINGER, AF	136
-	-	REF	-	SEE NOTE 4	MEMORY CHIP, PROGRAMMED	135
-	-	1	-	1633743-1	SERVO FEED LATCH ASM	133
-	1	1	1	1-22281-8	SPRING, COMPRESSION	121
-	1	1	1	1-18028-2	WASHER, FLAT, REG M4	119
-	-	REF	-	2119944-1	FEED FINGER ASSEMBLY, SF	117
	1	1	1	2256587-1	SCR, SET, SOFT TIP, M4	99
-	1	1	1	1-690438-0	FRONT STRIP GUIDE	96
-	2	2	2	2168083-1	SCR, SKT HD CAP, RoHS, M3 X 8.0	95
-	1	1	1	2168083-6	SCR, SKT HD CAP, RoHS, M5 X 65	93
-	1	1	1	455888-4	SPACER, CRIMPER	82
-	1	1	1	2119956-1	DOCUMENTATION PACKAGE	71
-	1	-	1	2119740-1	TAG, IDENTIFICATION	67
-	2	2	2	2168078-1	SCREW, DRIVE, RH, RoHS, 2 x .188	66
-	1	1	1	2119793-1	LIMITER, ADJUSTMENT BOLT	63
	3	3	3	992763-5	SCR, SET, SOC, CONE POINT, M3 x 4.0	62
-	1	1	1	2-18032-5	SCR, SET, FLT POINT M5 X 20.0	61
-	-	-	1	5-18022-5	SCR, HEX HD CAP, M4 X 6.0	59
-	-	-	1	1338685-1	PAWL, FEED	56
-	2	2	2	2168083-8	SCR, SKT HD CAP, RoHS, M4 X 16	53
-	1	1	1	5018030-1	NUT, HEX, REG, RoHS, M3	52
-	1	1	1	811242-5	BUMPER, HOLD DOWN	51
-	1	1	1	690753-2	SPACER, TONKER	50
-	-	-	1	18023-9	SCR, SKT HD CAP M4 X 6.0	49
-	1	1	1	2079383-7	SCR, BHSC, RoHS (M8 X 25)	41
-	1	1	1	2119645-1	DISC, NUMBERED FA WIRE ADJUSTMENT	40
-	1	1	1	2119957-1	APPLICATOR SHIM PACK	39
-	1	1	1	1-2119644-2	RAM WASHER, PRECISION	38
-	1	1	1	1-1752356-1	SUPPORT, TERMINAL	34
-	2	2	2	2079383-5	SCR, BHSC, RoHS (M4 X 20)	33
-	1	1	1	2161328-1	HEX HEAD, FLANGED, M5 x 8mm LONG	32
-	1	1	1	1320908-7	SPACER, STRIP GUIDE	30
-	1	1	1	1901086-1	PLATE, STRIP GUIDE	29
-	1	1	1	455888-3	SPACER, CRIMPER	28
-	2	2	2	22283-1	SPRING, COMPRESSION	27
-	1	1	1	356835-1	LEVER, DRAG RELEASE	26
-	1	1	1	1803142-1	DRAG, TERMINAL	25
-	1	1	1	1320928-2	STRIP GUIDE	24
-	1	1	1	980371-4	SCR, SKT HD SHLDR 5.0 DIA X 6.0	23
-	1	1	1	2168083-2	SCR, SKT HD CAP, RoHS, M4 X 8.0	21
-	1	1	1	1-18028-2	WASHER, FLAT, REG M4	20
-	1	1	1	690472-2	STRIPPER	19
	1	1	1	2119806-1	INSERT, SHEAR	13
-	1	1	1	3-22280-3	SPRING, COMPRESSION	12
-	1	1	1	1-18023-1	SCR, SKT HD CAP M4 X 10.0	11
	1	1	1	2119805-1	SHEAR HOLDER, FRONT	10
	1	1	1	462006-6	FLOATING SHEAR, FRONT	9
	1	1	1	2161316-3	ANVIL, COMBINATION	8
-	1	1	1	2-240641-9	SPACER	7
-	-	-	-	-	-	6
-	1	1	1	1-1722335-0	SHEAR DEPRESSOR ASSEMBLY	5
-	1	1	1	5-238011-2	BLOCK, CRIMPER SPACER	4
	1	1	1	1722335-7	CRIMPER, INSULATION F	3
-	-	-	-	-	-	2
	1	1	1	2217302-1	CRIMPER, WIRE, CONICAL BLEND	1
-77	-27	-25	-22	PART NO	DESCRIPTION	ITEM NO

DIMENSIONS:		TOLERANCES UNLESS OTHERWISE SPECIFIED:		DATE	BY	APPV
mm	0 PLC	±		18JAN2012	R. KNEPPER	
	1 PLC	±		18JAN2012	T. ELBIN	
	2 PLC	±		18JAN2012	M. CLIFFORD	
	3 PLC	±				
	4 PLC	±				
	ANGLES	±				
	FINISH	±				

NAME	SIZE	CAGE CODE	DRAWING NO	RESTRICTED TO
STE TE Connectivity Harrisburg, PA 17105-3608	A1	00779	2151550	-
Customer Accessible Production Drawing				SCALE 1:2 SHEET 3 OF 4 REV F

LOC	DIST	REV	DATE	BY	APPV
A	66				

FEED TYPE PNEUMATIC

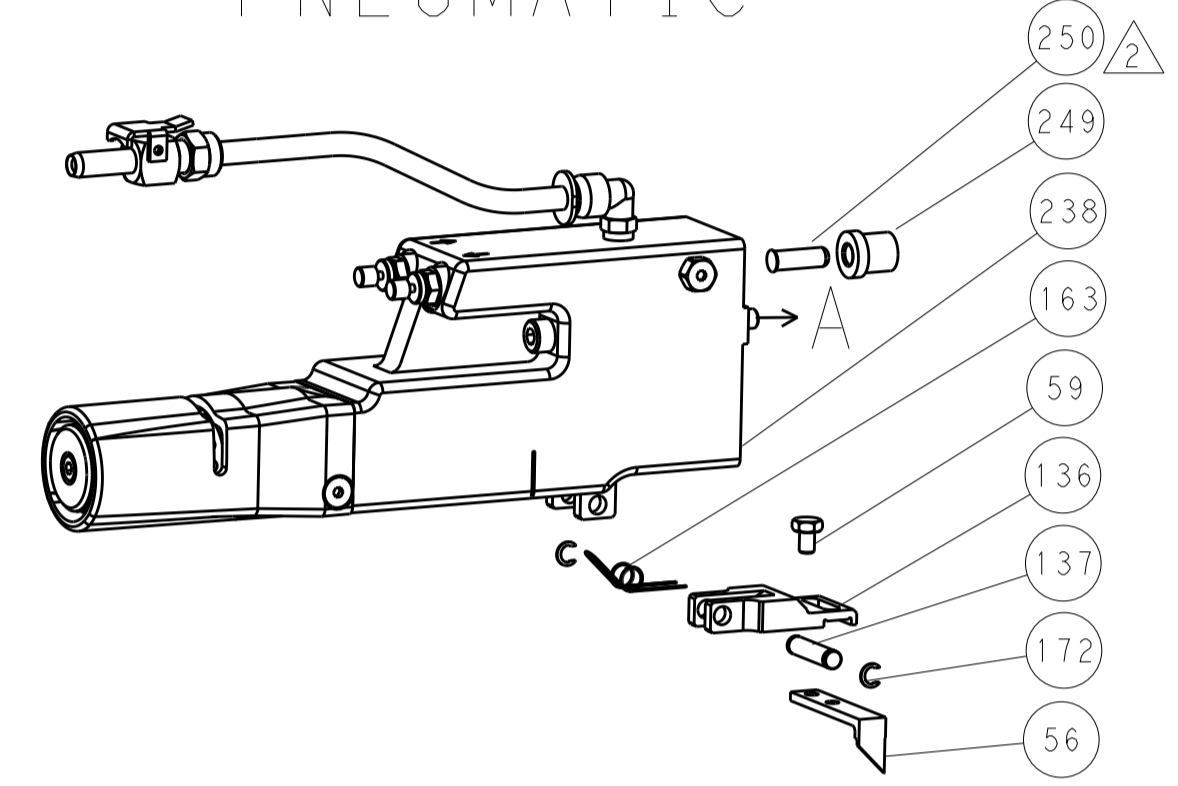

SERVO LATCH PLATE

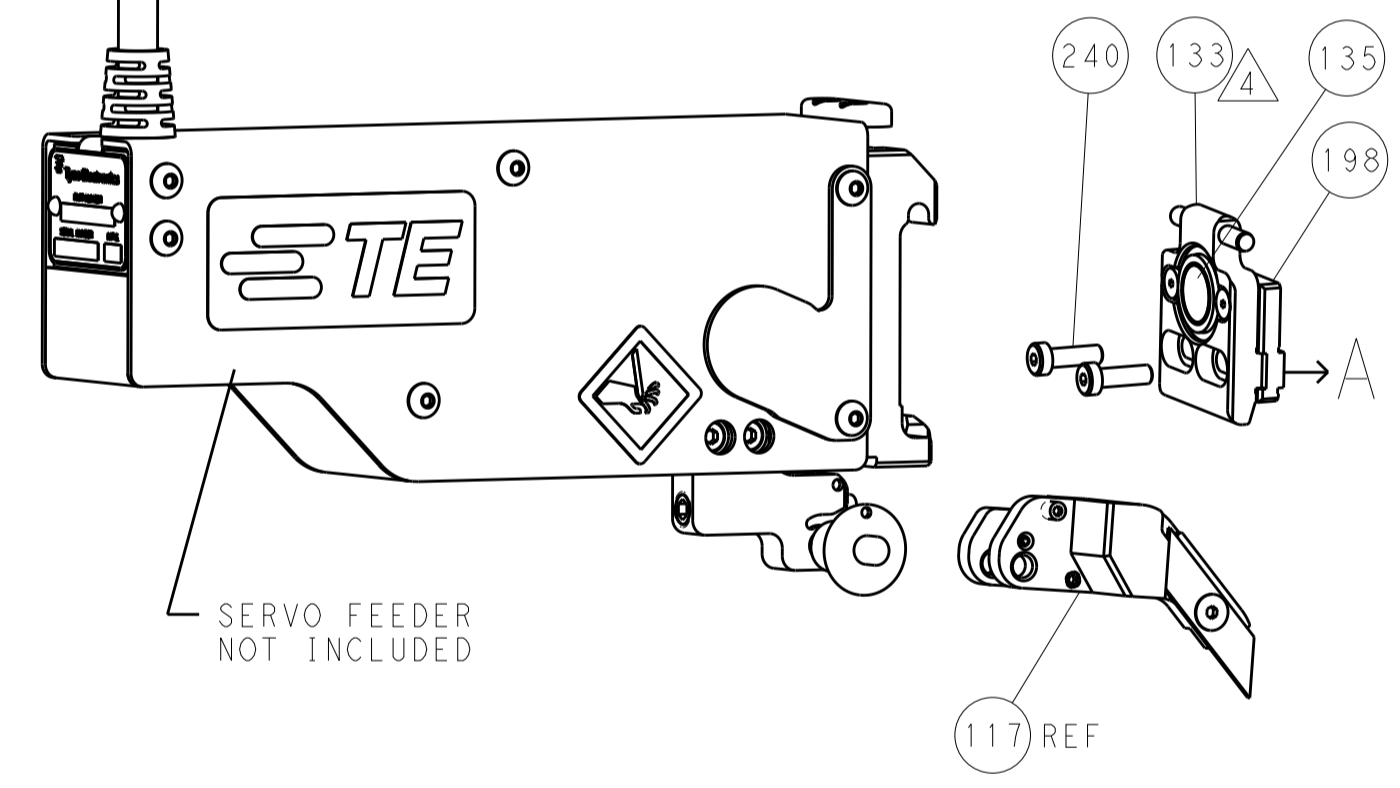

CAM POSITIONS

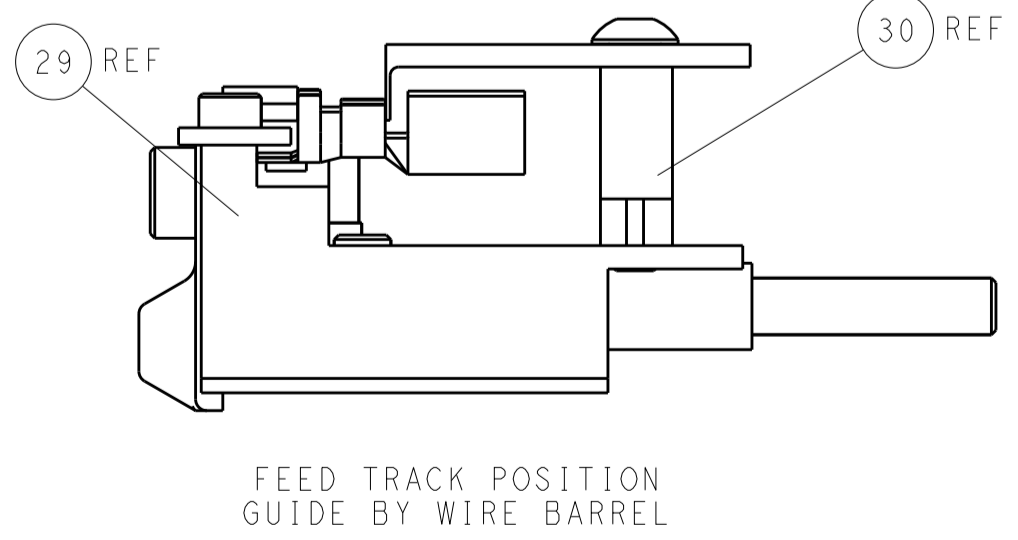
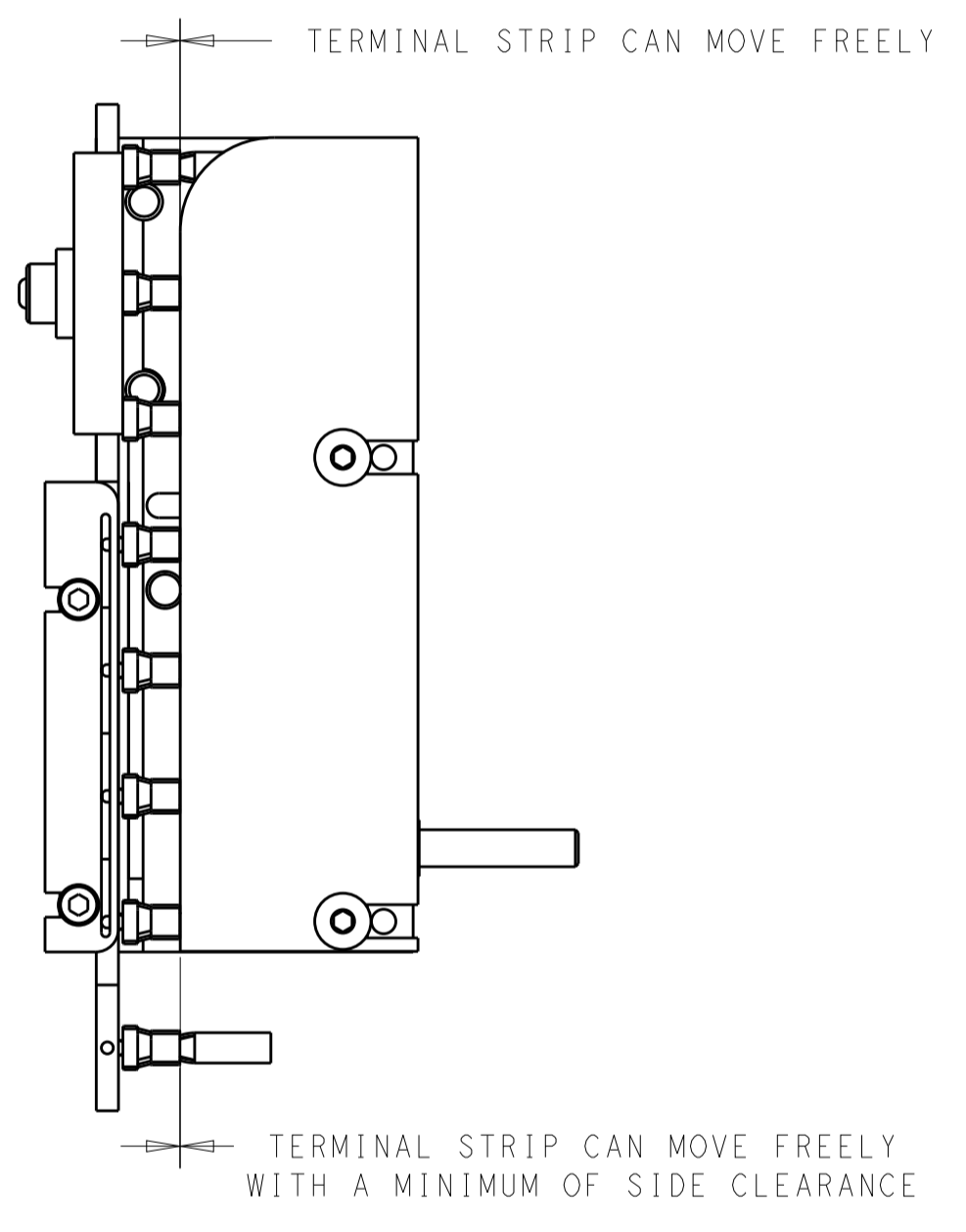
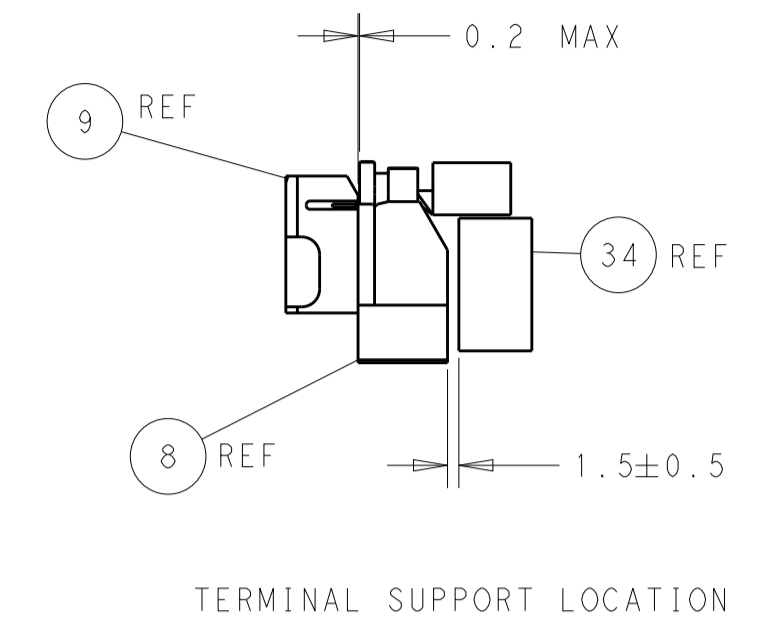
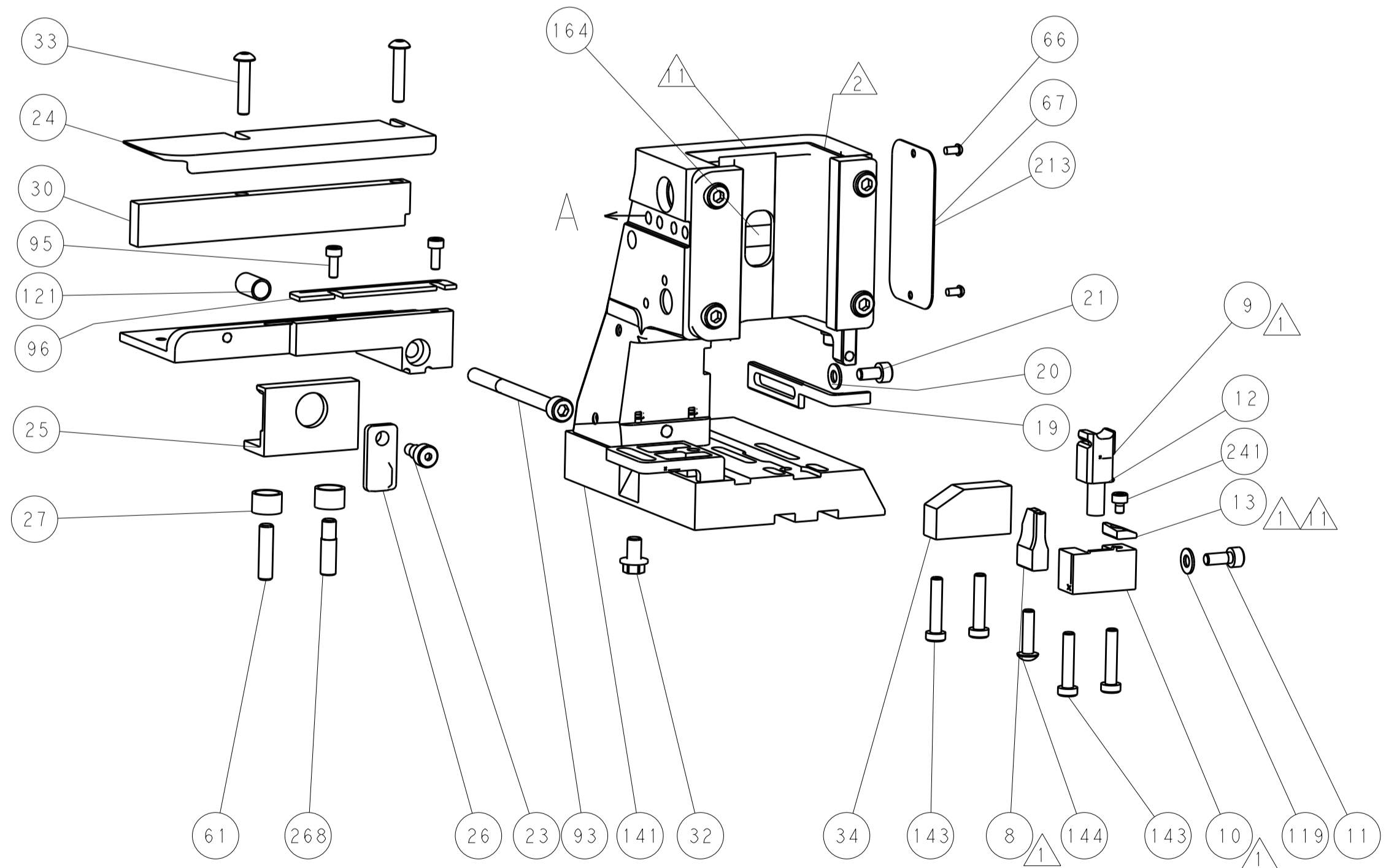
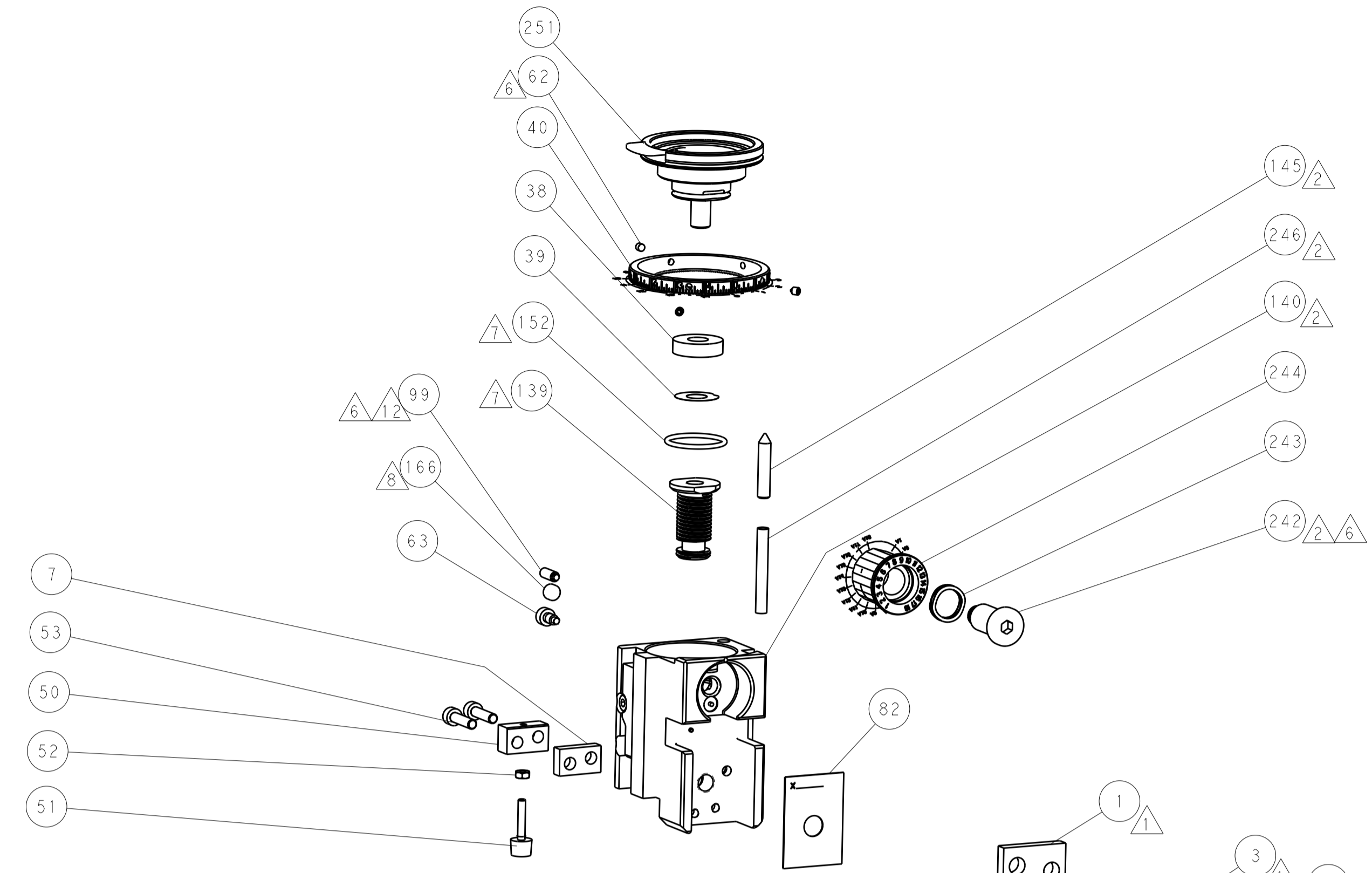
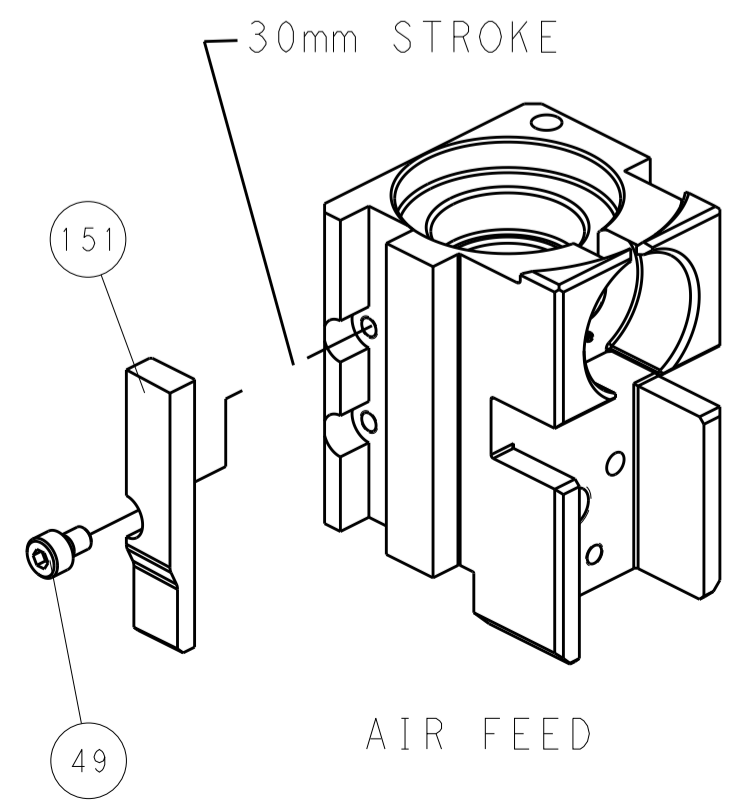

PACIFIC VERSION
 Shown on sheets 3 of 4 & 4 of 4
 (Atlantic version shown on sheets 1 of 4 & 2 of 4)

DIMENSIONS:		TOLERANCES UNLESS OTHERWISE SPECIFIED:		DWN: R. KNEPPER 18JAN2012		STE TE Connectivity	
mm	0 PLC ±	1 PLC ±	2 PLC ±	3 PLC ±	4 PLC ±	Harrisburg, PA 17105-3608	
MATERIAL:		FINISH:		APV: T. ELBIN 18JAN2012		NAME: Ocean Side Feed Applicator	
				M. CLIFFORD 18JAN2012		SIZE: A1	
				PRODUCT SPEC:		CAGE CODE: 00779	
				APPLICATION SPEC:		DRAWING NO: 2151550	
				WEIGHT:		SCALE: 1:2	
				Customer Accessible Production Drawing		SHEET 4 OF 4 REV F	